

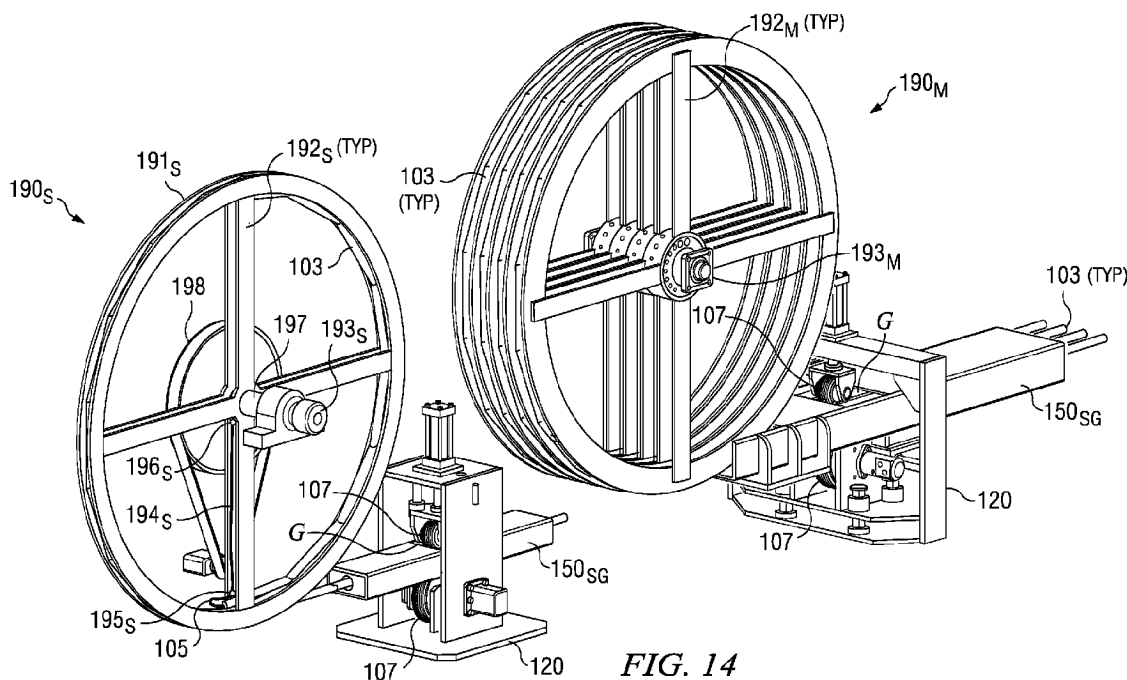

(86) **Date de dépôt PCT/PCT Filing Date:** 2014/03/14
 (87) **Date publication PCT/PCT Publication Date:** 2014/09/18
 (85) **Entrée phase nationale/National Entry:** 2015/09/15
 (86) **N° demande PCT/PCT Application No.:** US 2014/028760
 (87) **N° publication PCT/PCT Publication No.:** 2014/144376
 (30) **Priorité/Priority:** 2013/03/15 (US13/832,379)

(51) **Cl.Int./Int.Cl. B08B 9/04** (2006.01),
B08B 9/027 (2006.01)
 (71) **Demandeur/Applicant:**
THOMAS ENGINEERING SOLUTIONS &
CONSULTING, LLC, US
 (72) **Inventeurs/Inventors:**
THOMAS, WILLIAM C., US;
THOMAS, WILLIAM J., III, US;
DECUIR, PERRY J., JR., US;
BOLlich, KEVIN JUDE GERARD, US
 (74) **Agent:** MBM INTELLECTUAL PROPERTY LAW LLP

(54) **Titre : DEVIDOIR A LANCES MULTIPLES POUR NETTOYAGE ET INSPECTION INTERNES DE TUBULURES**
 (54) **Title: MULTI-LANCE REEL FOR INTERNAL CLEANING AND INSPECTION OF TUBULARS**



(57) **Abrégé/Abstract:**

A multi-lance reel assembly comprising a plurality of reel assemblies disposed to rotate about an axle. Each reel assembly rotates independently of the others. Each reel assembly further comprises a plurality of spokes separating a rim from a hub. Each hub provides a hub groove on each internal hub surface, and a hub aperture connecting each external hub surface with the hub groove. When the reel assemblies are received onto the axle, axle grooves on the axle align with the hub grooves to form a continuous ring aperture for each reel assembly. Separate axle apertures connect either one of the end faces of the axle with each axle groove, providing a separate passageway from each external hub surface to an axle end face. Hollow lances may be spooled onto each reel assembly. Carrier hardware such as hoses or conductors deployed therein may connect to the hub apertures.