



US 20140261580A1

(19) **United States**

(12) **Patent Application Publication**

Thomas et al.

(10) **Pub. No.: US 2014/0261580 A1**

(43) **Pub. Date: Sep. 18, 2014**

(54) **SINGLE-LANCE REEL FOR INTERNAL CLEANING AND INSPECTION OF TUBULARS**

Publication Classification

(71) Applicant: **EXTREME HYDRO SOLUTIONS, L.L.C.**, New Iberia, LA (US)

(51) **Int. Cl.**
B08B 9/032 (2006.01)
B08B 9/043 (2006.01)

(72) Inventors: **William C. Thomas**, Lafayette, LA (US); **William J. Thomas, III**, New Iberia, LA (US); **Perry J. DeCuir, Jr.**, Rochester Hills, MI (US); **Kevin Jude Gerard Bollich**, Lafayette, LA (US)

(52) **U.S. Cl.**
CPC **B08B 9/0321** (2013.01); **B08B 9/043** (2013.01)
USPC **134/166 C**; 15/104.05

(73) Assignee: **EXTREME HYDRO SOLUTIONS, L.L.C.**, New Iberia, LA (US)

(57) **ABSTRACT**

A single-lance reel assembly comprising a reel assembly received onto and disposed to rotate about an axle at a rotary union. The reel assembly further comprises a plurality of spokes separating a rim from a hub. Hoses, electrical conduits, conductors or other similar carrier hardware deployed within hollow lances spooled on the reel assembly may be supplied via the rotary union and by further hose connection structure deployed on the hub and/or the rim. Embodiments of the reel assembly are powered by either a direct or indirect drive.

(21) Appl. No.: **13/832,417**

(22) Filed: **Mar. 15, 2013**

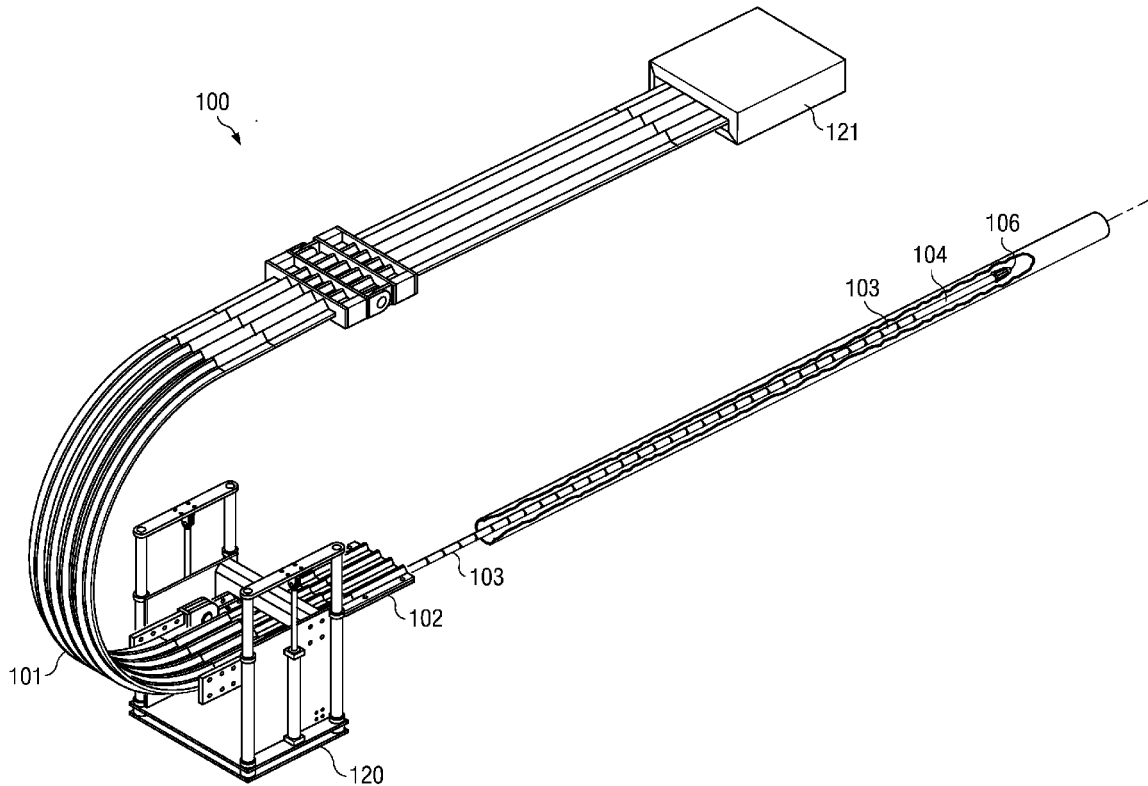

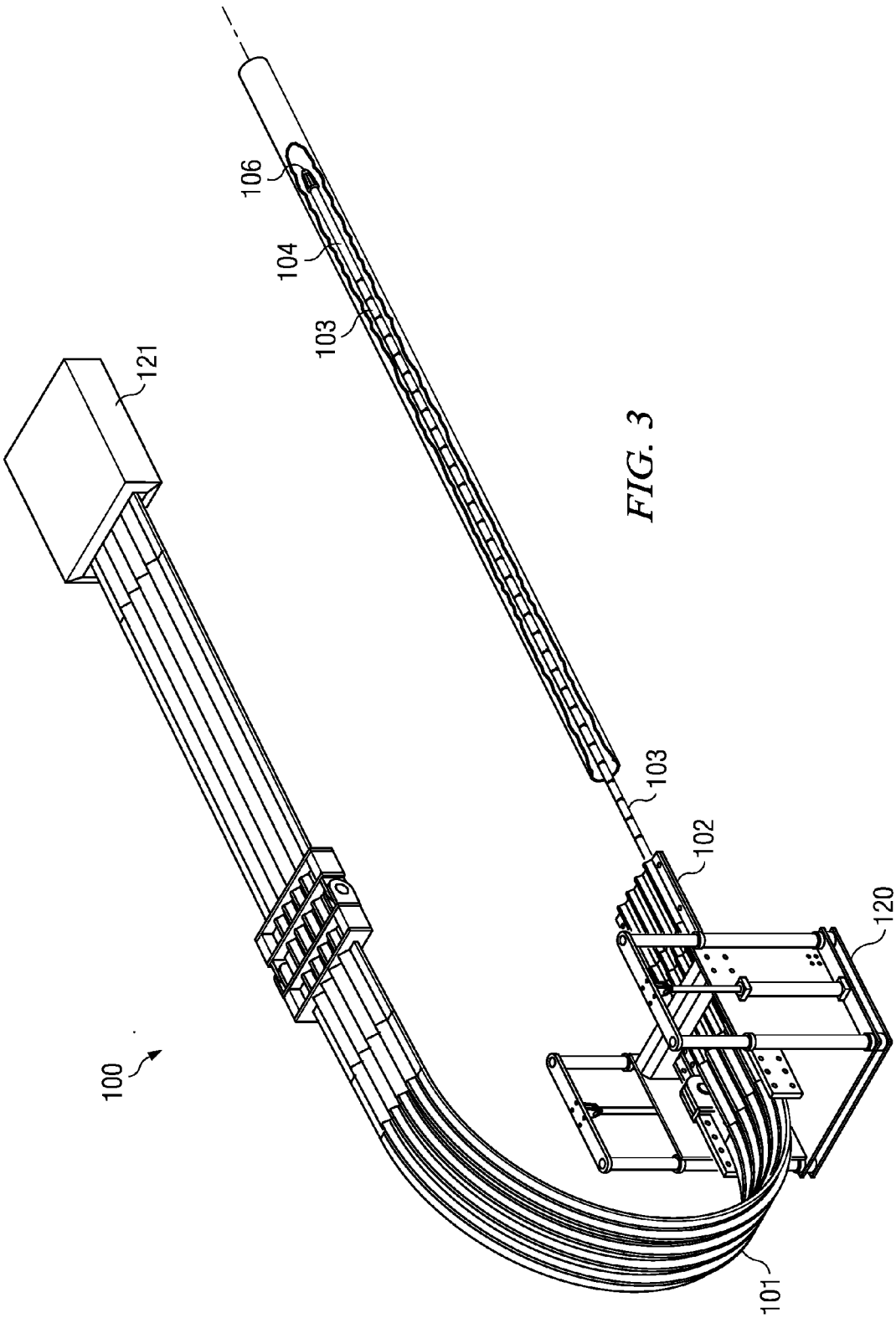

FIG. 3

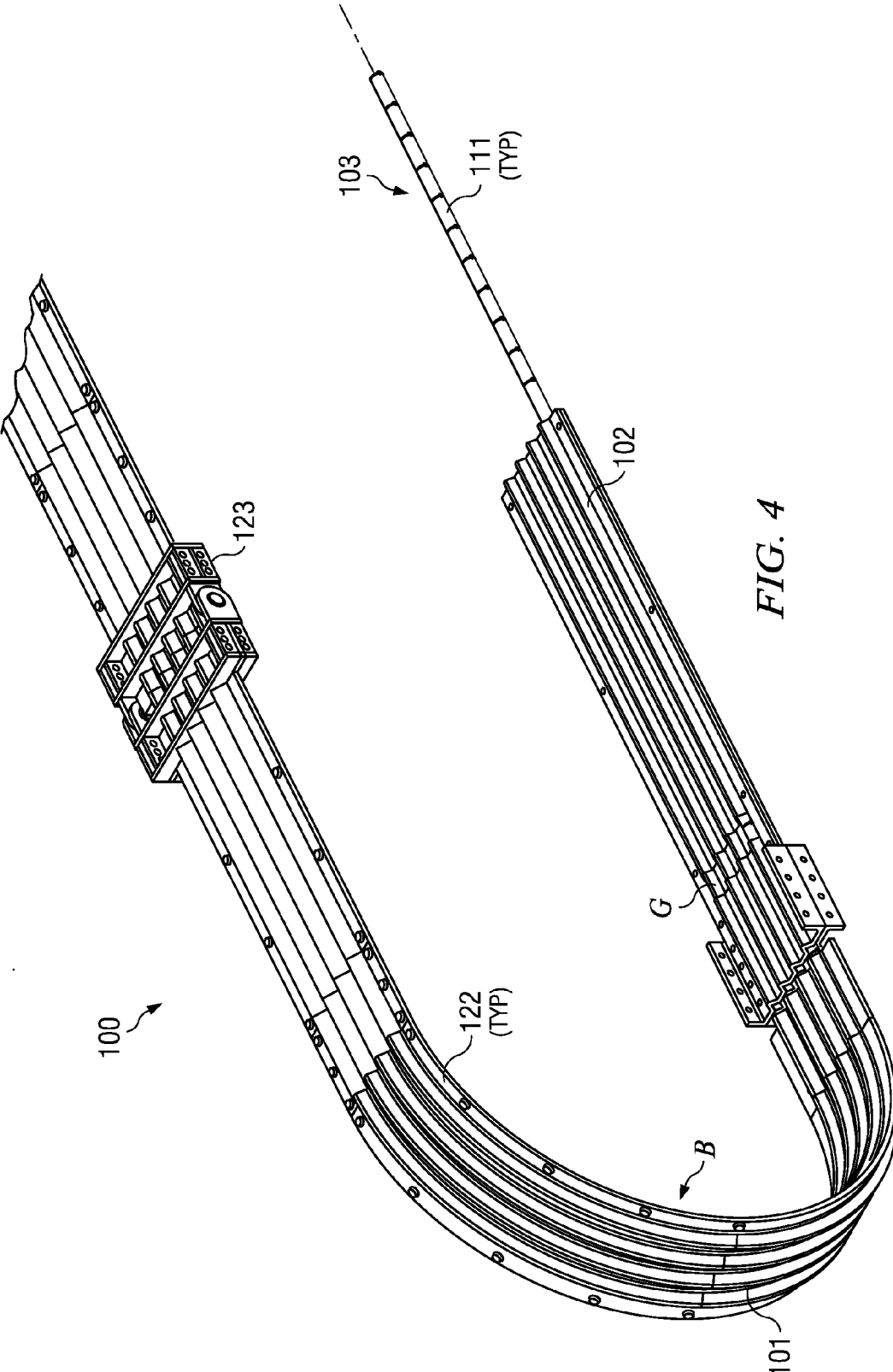

FIG. 4

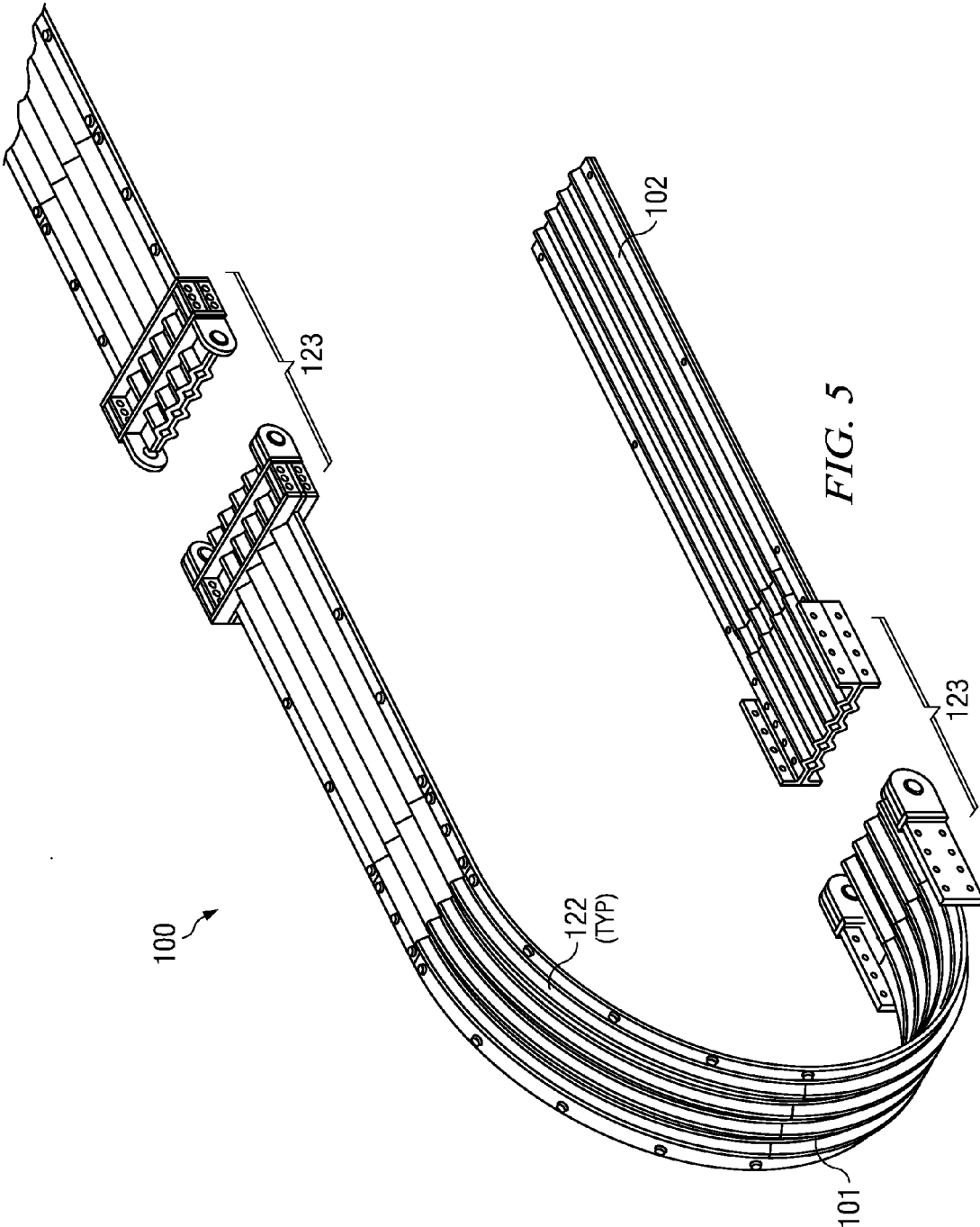
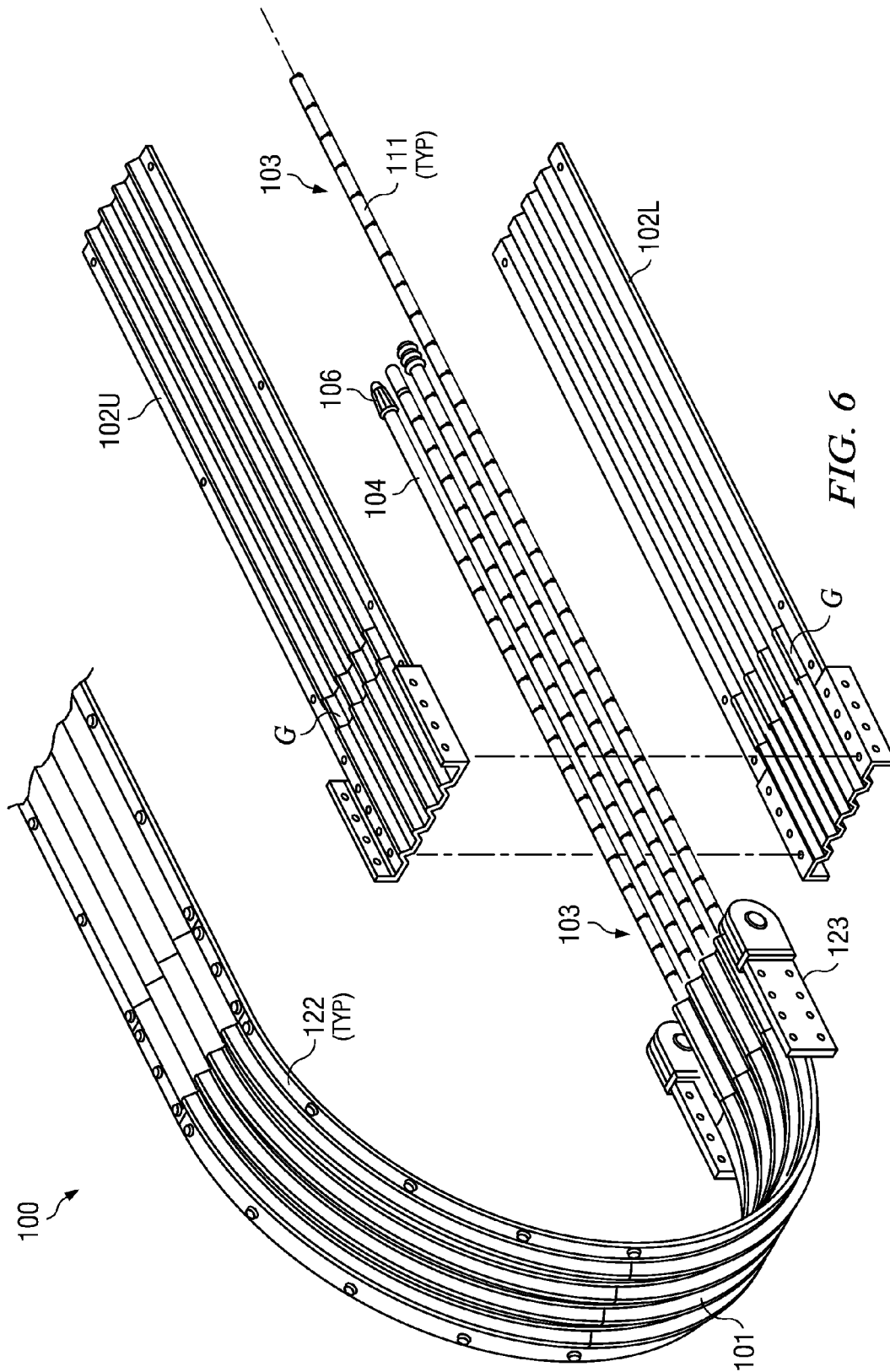
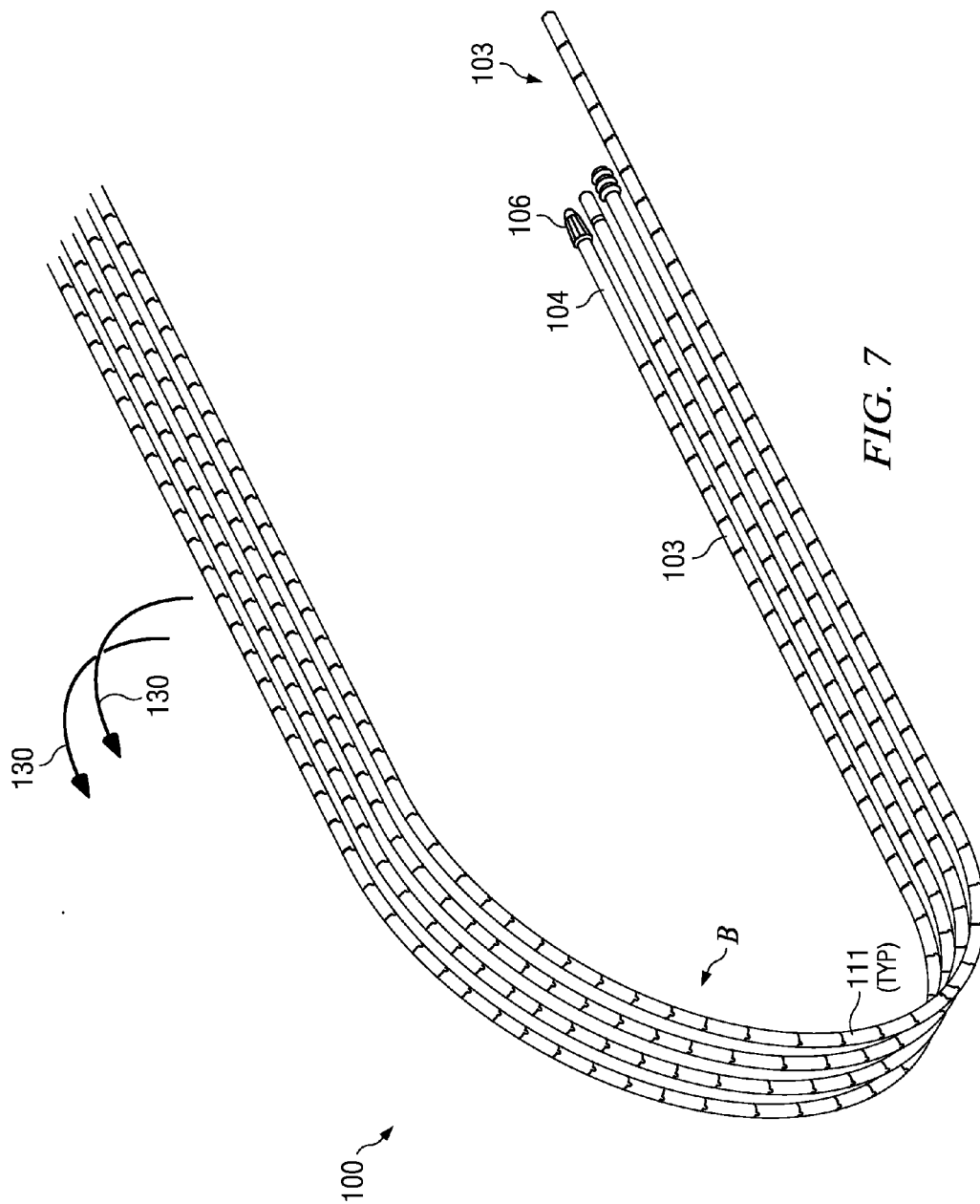

FIG. 5





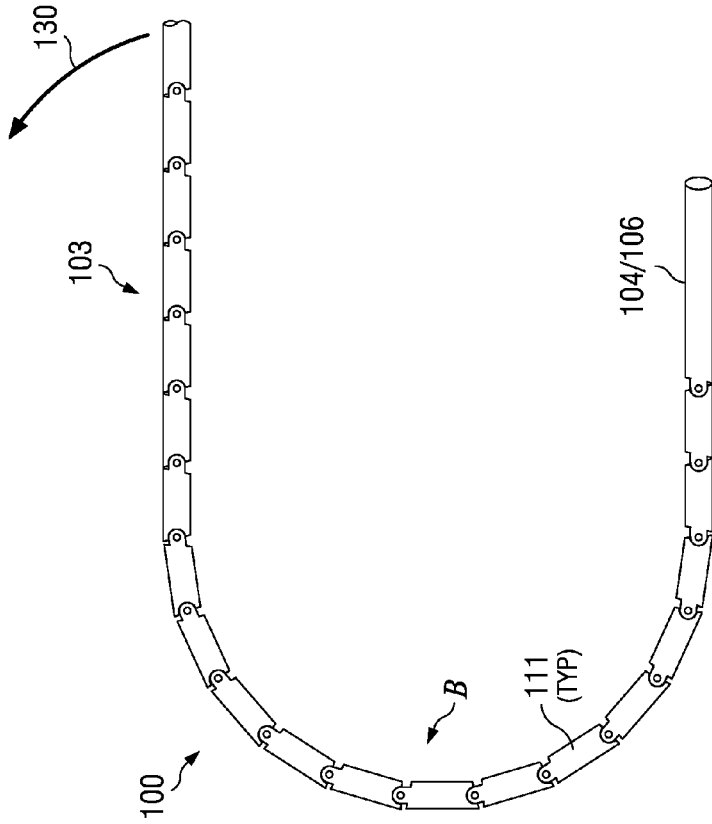

FIG. 8

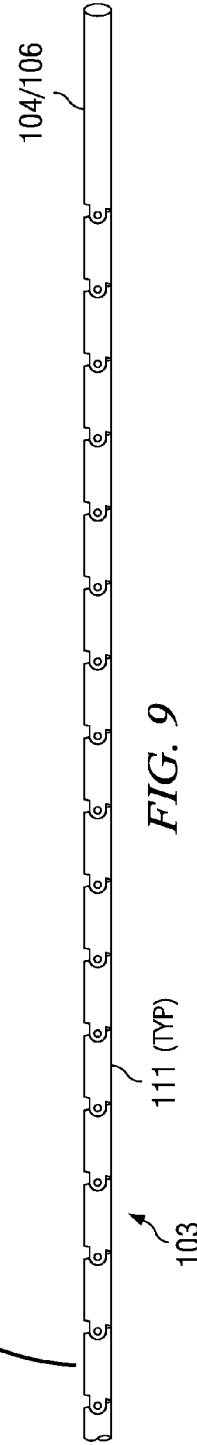

FIG. 9

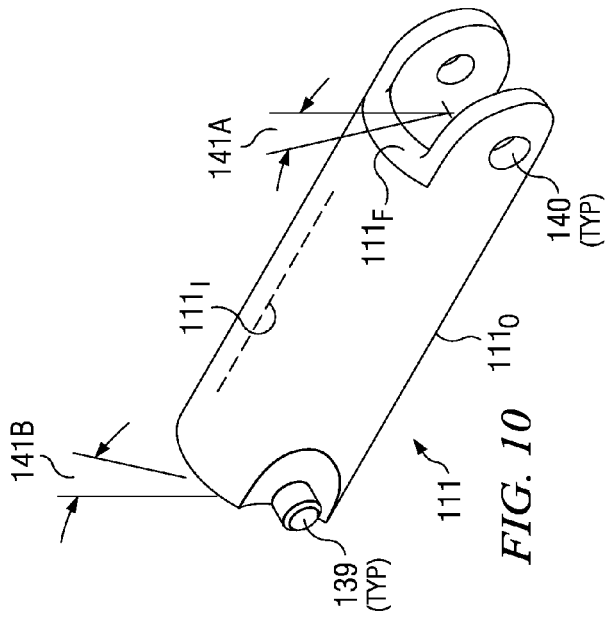

FIG. 10

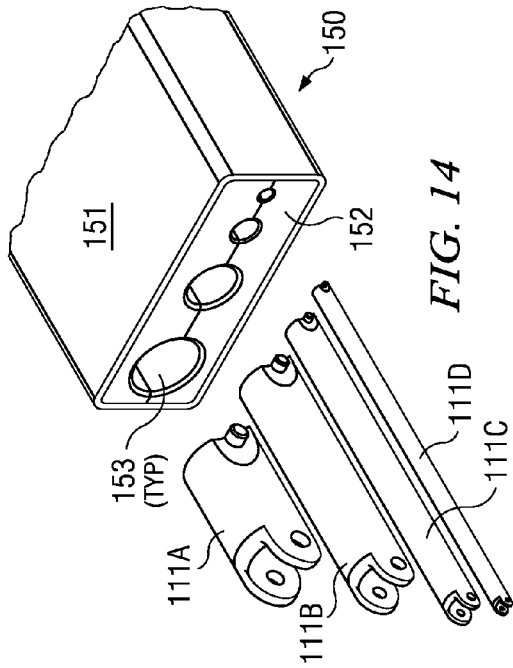

FIG. 14

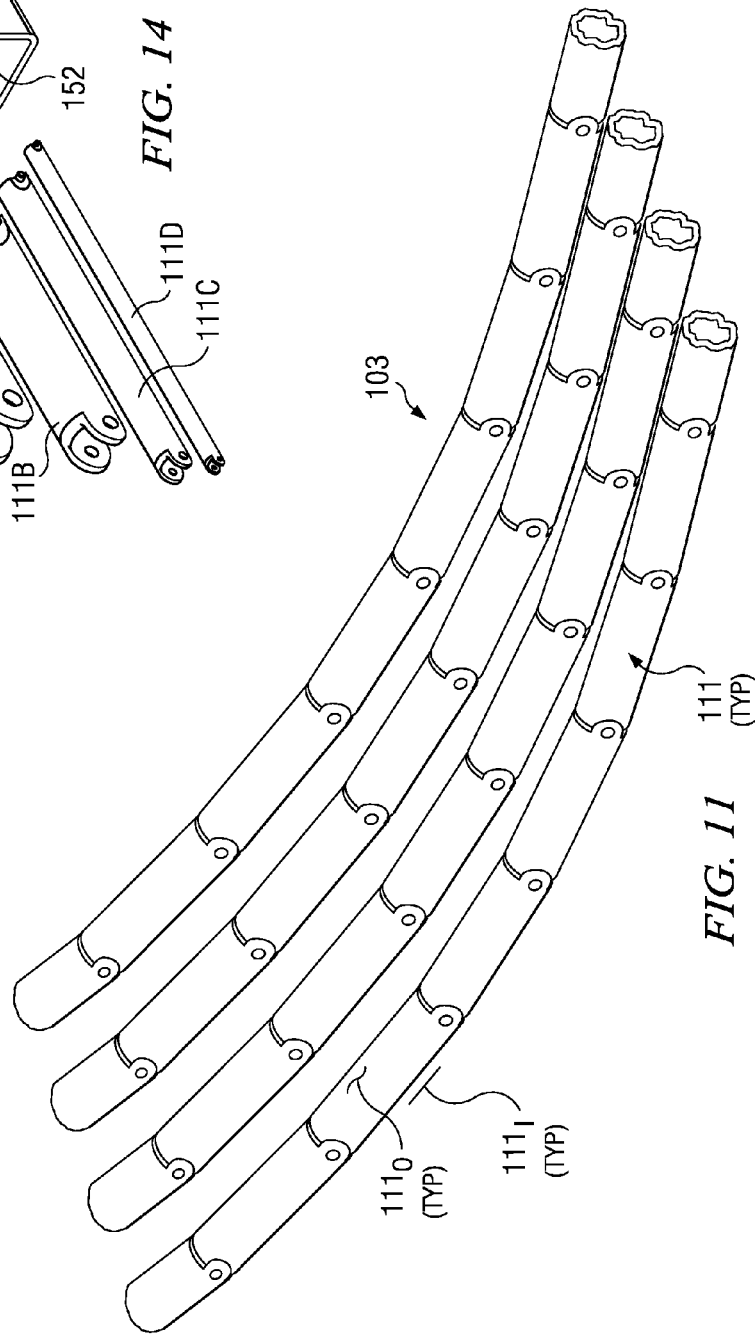

FIG. 11

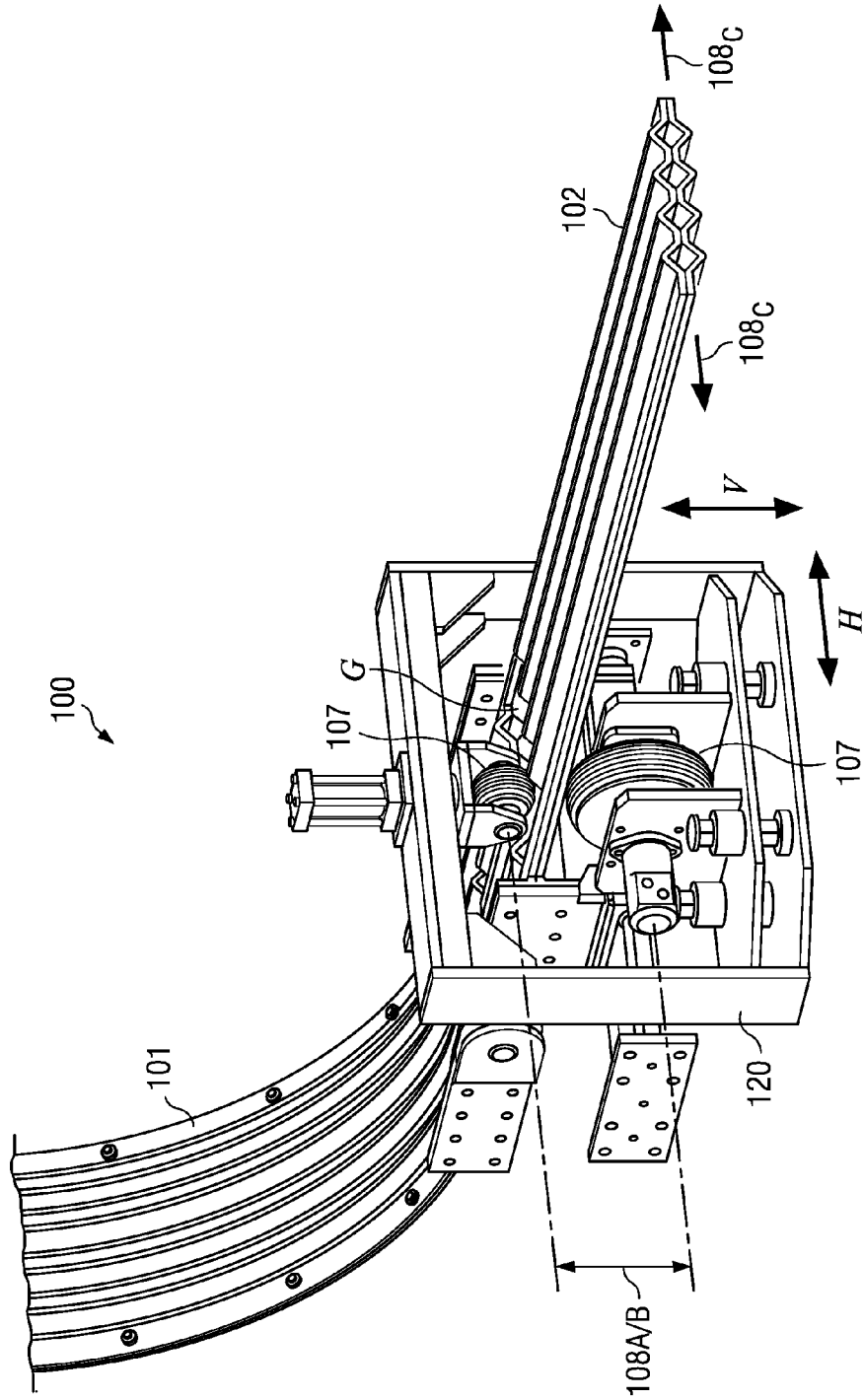

FIG. 12

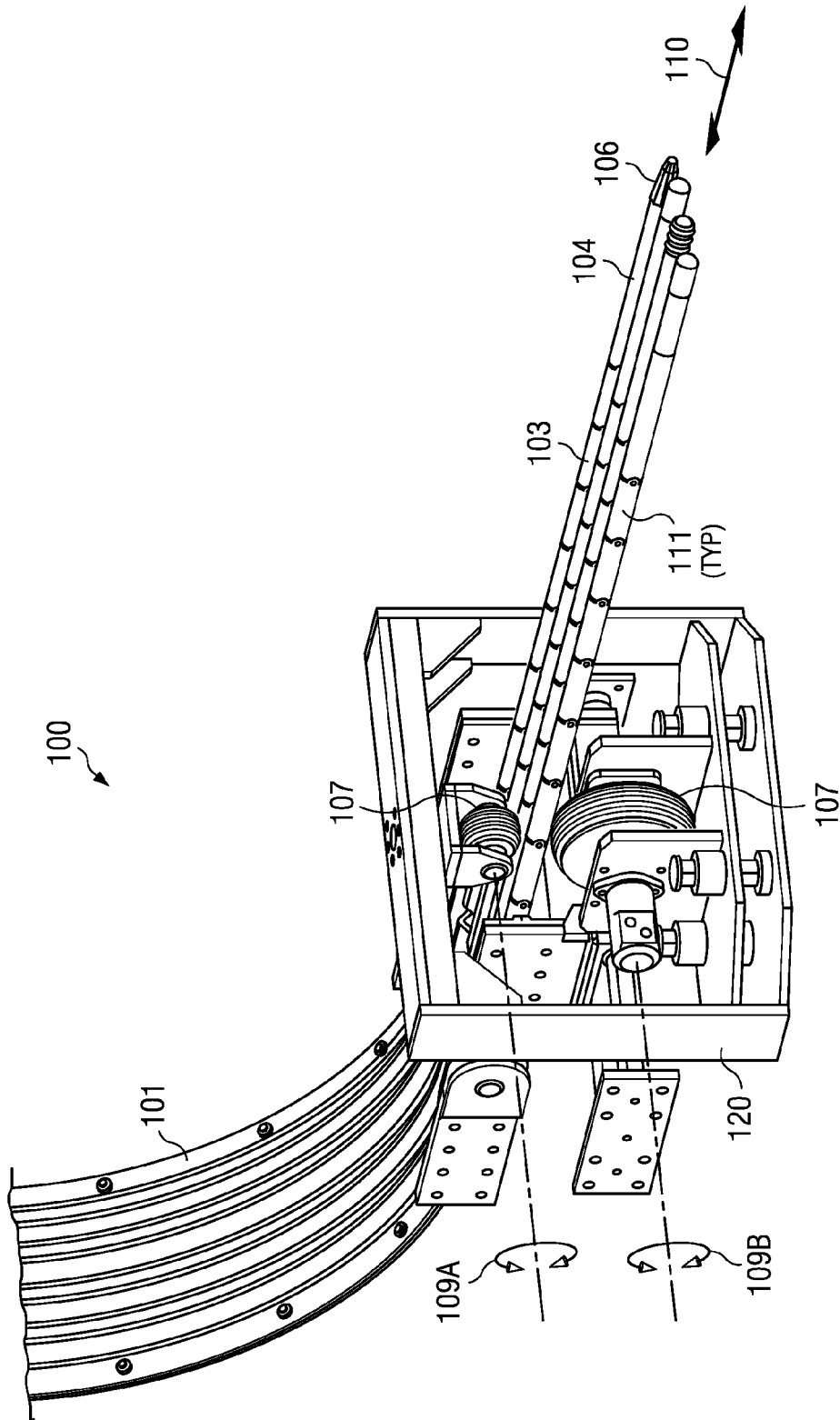
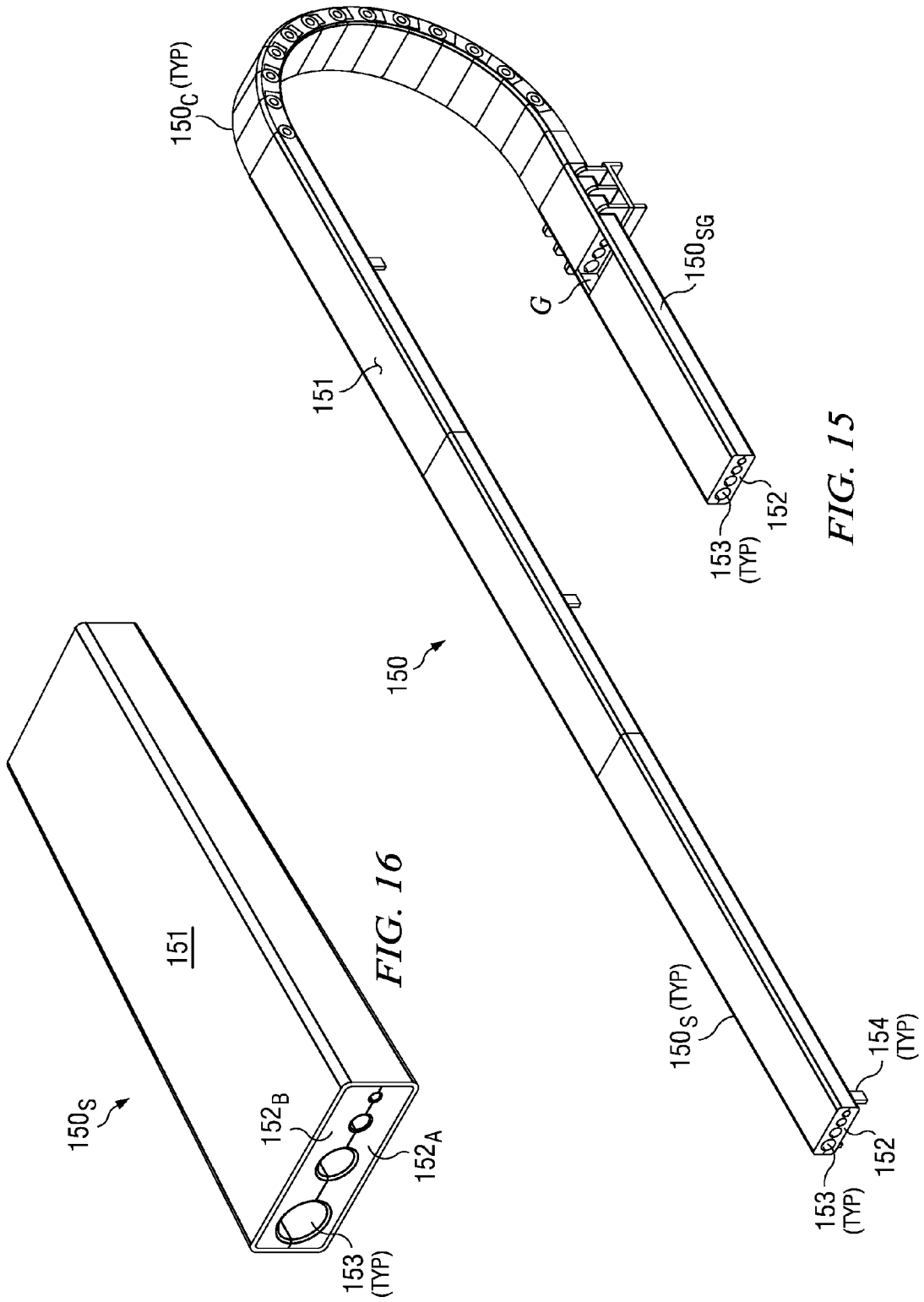

FIG. 13



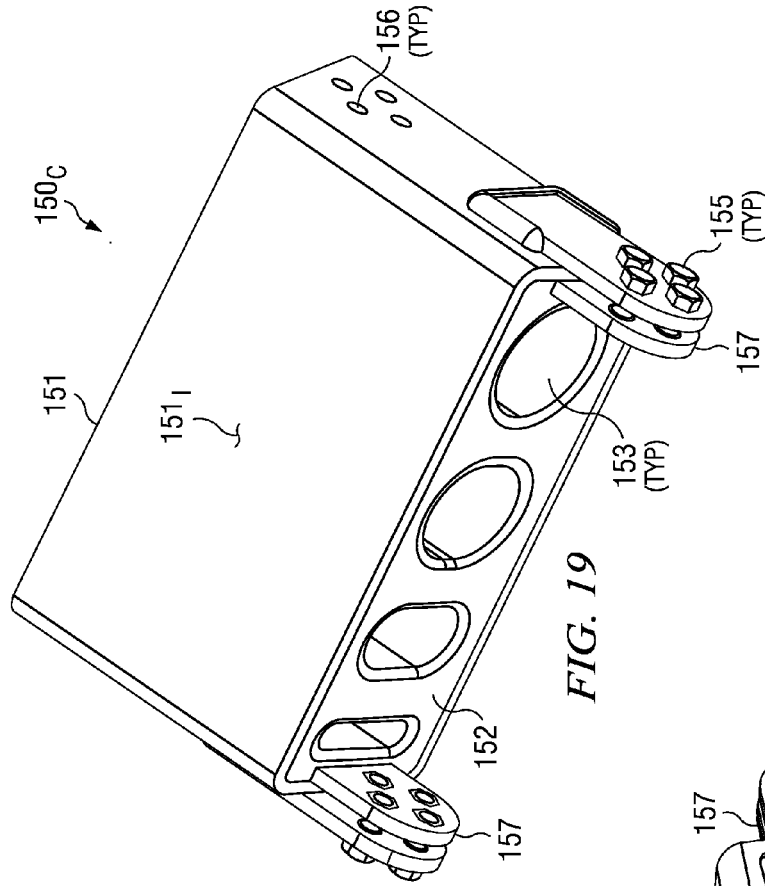

FIG. 17

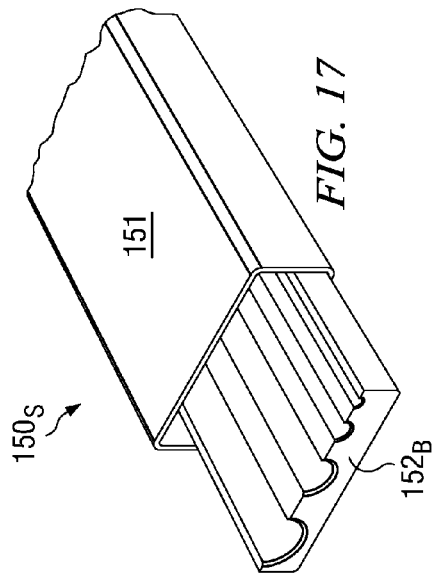

FIG. 18

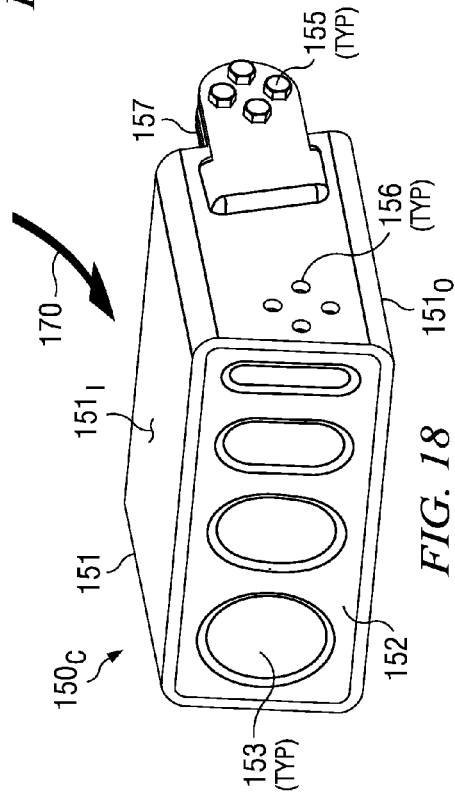
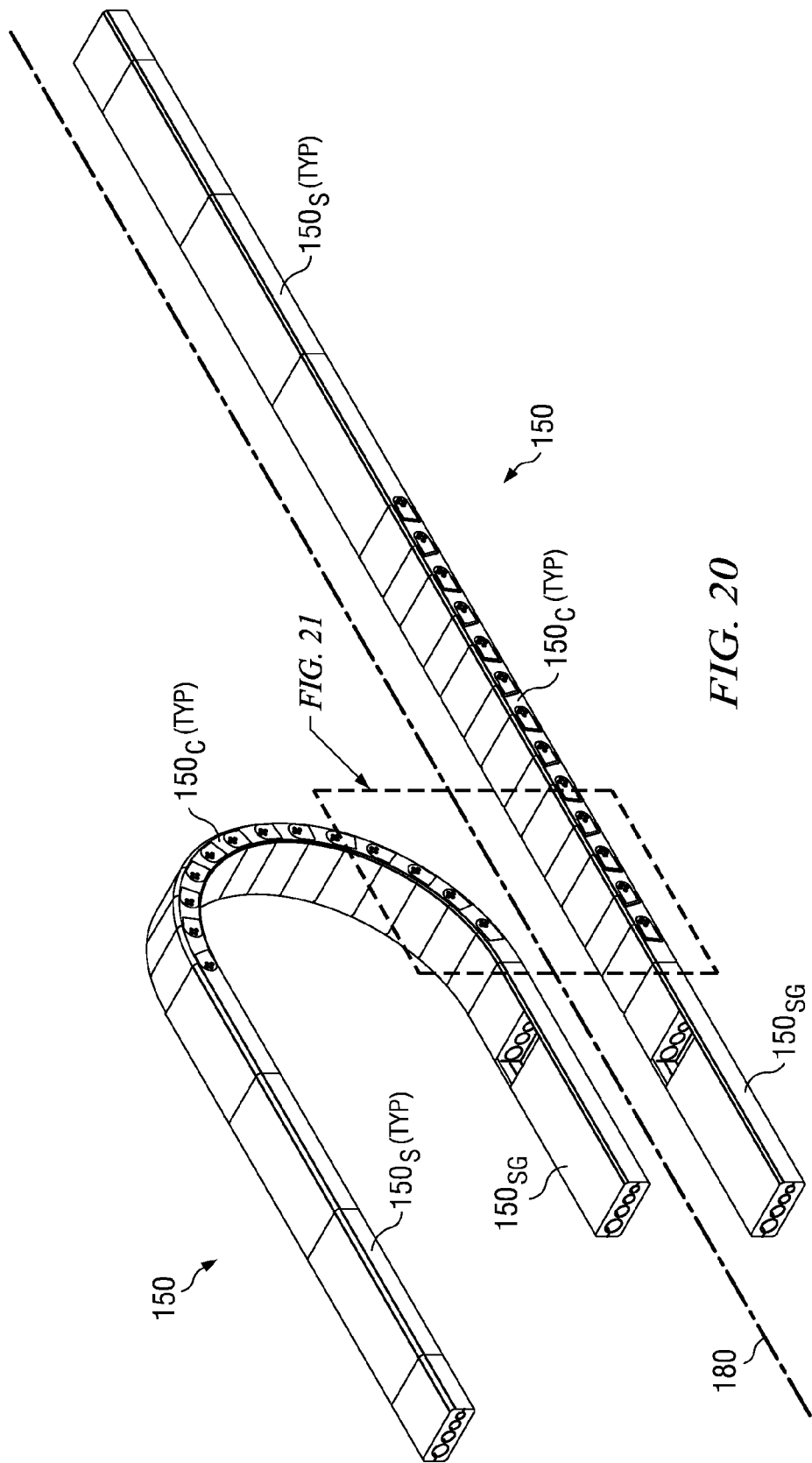

FIG. 19



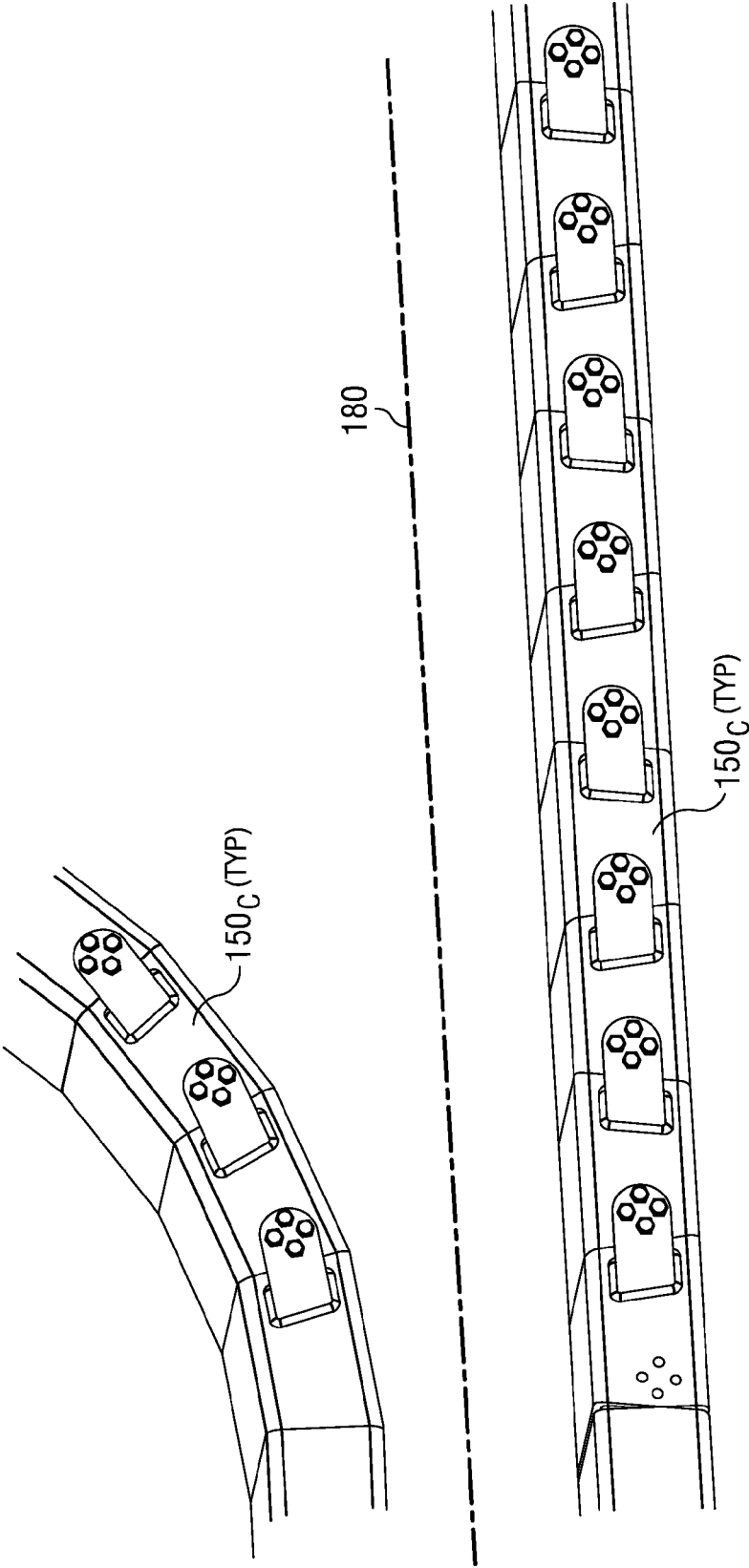

FIG. 21

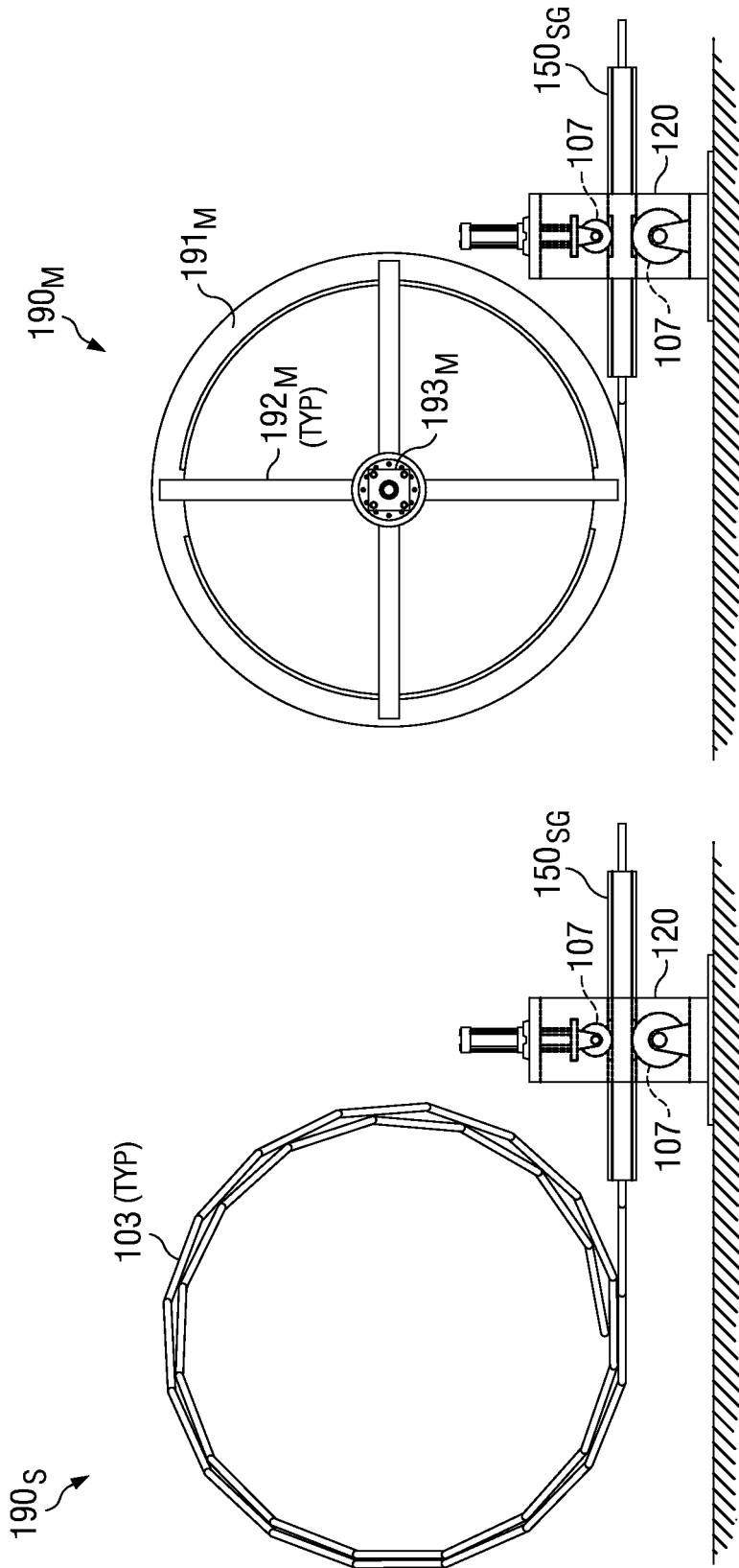

FIG. 22

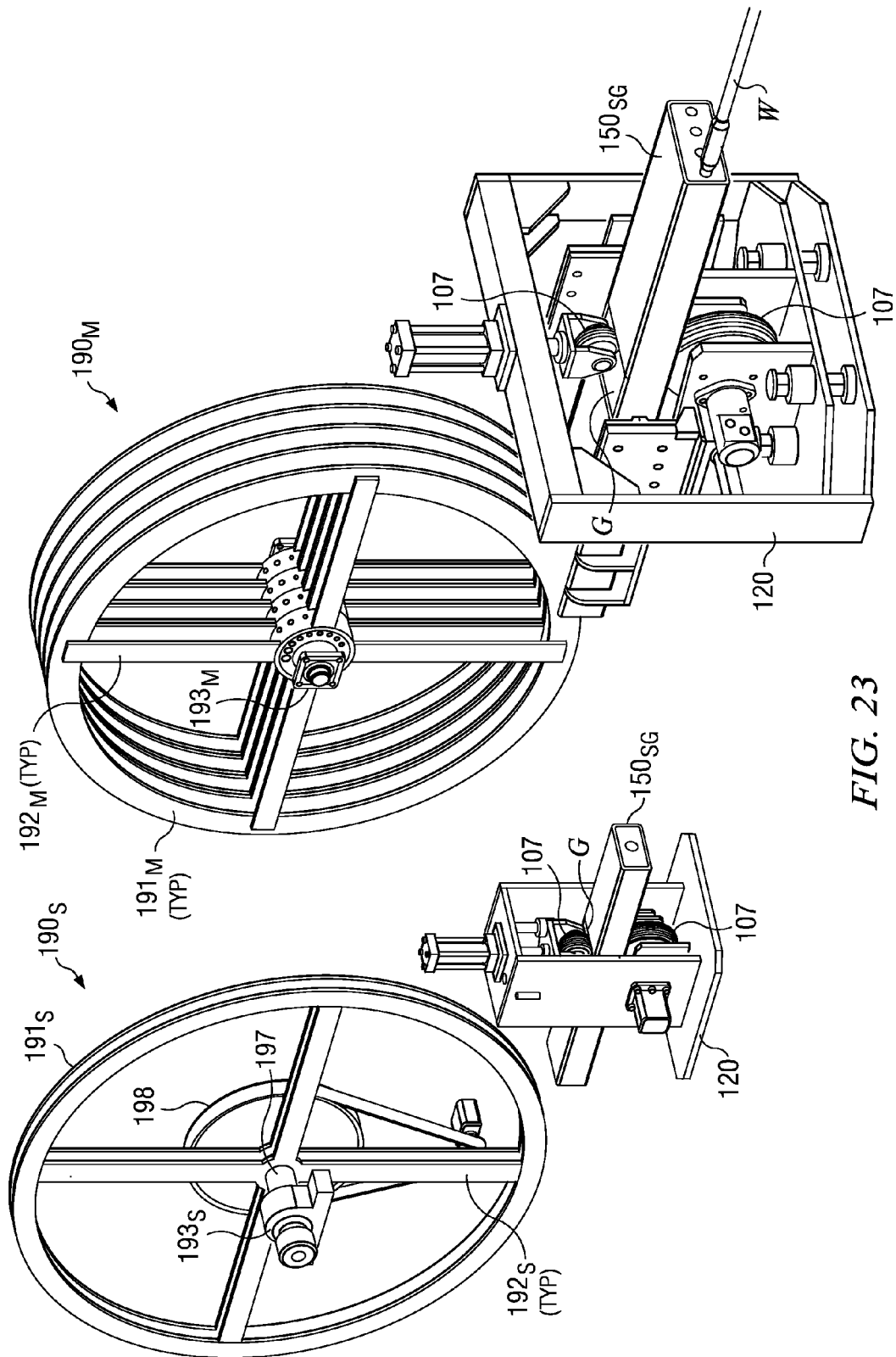

FIG. 23

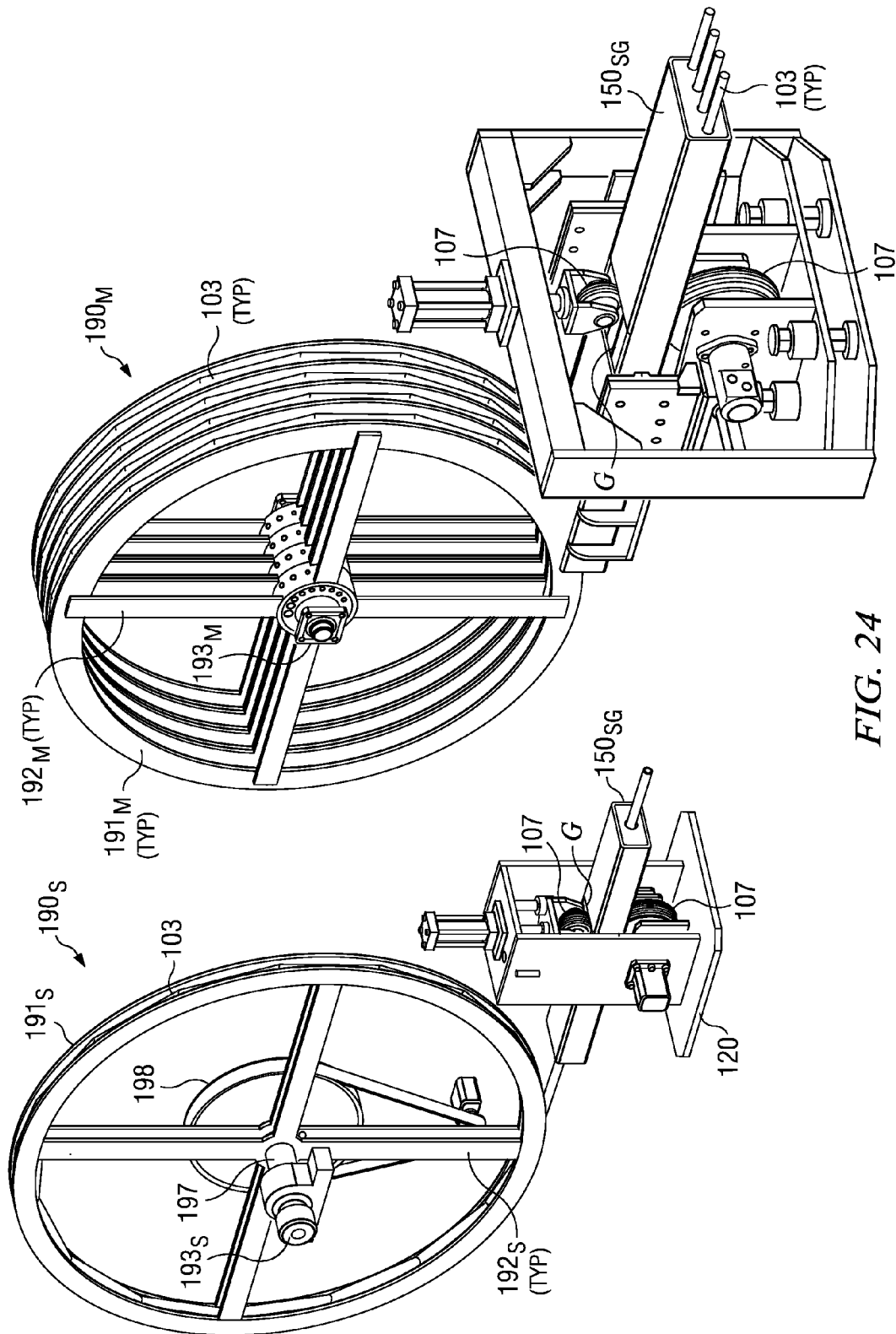

FIG. 24

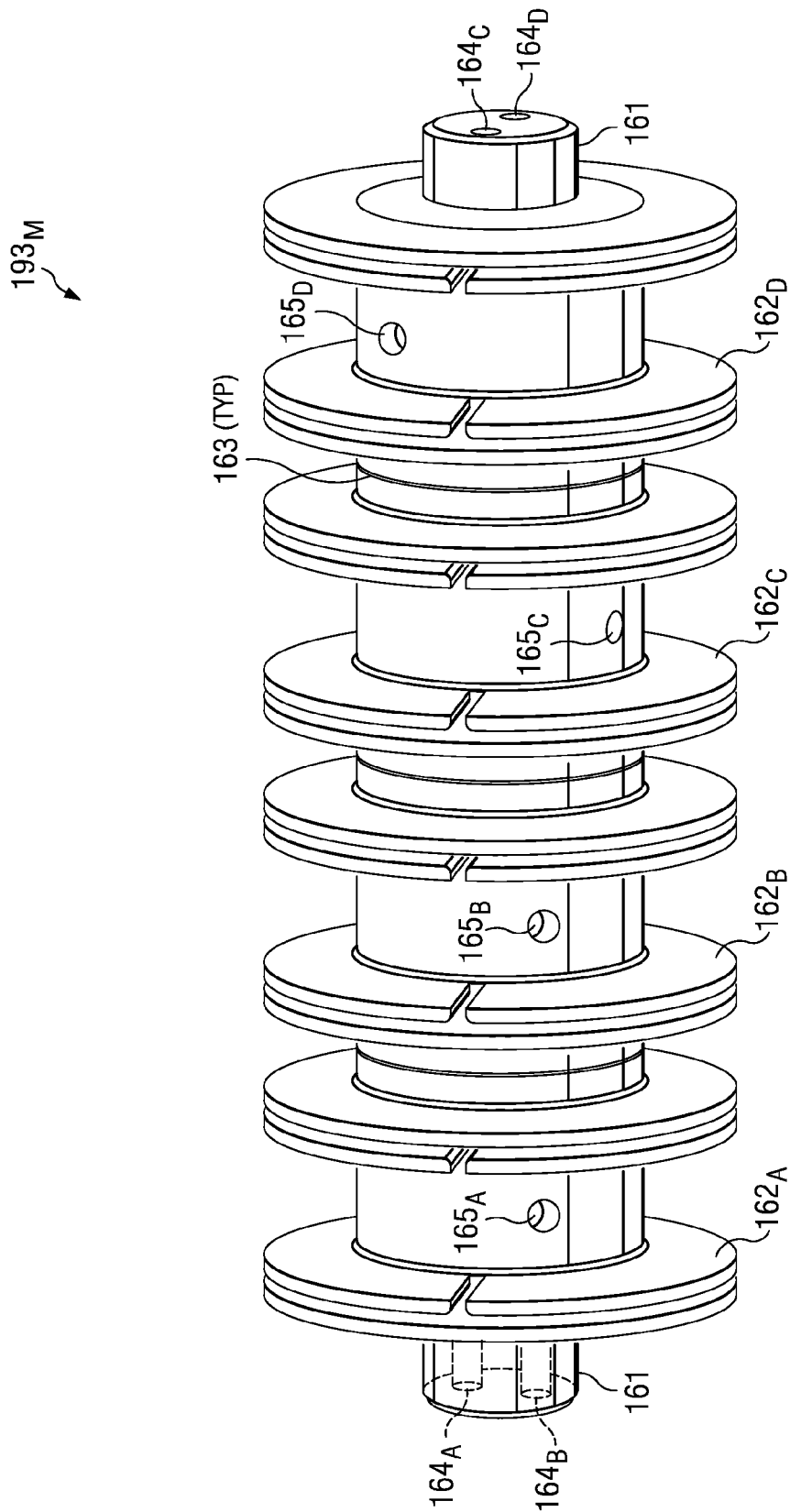

FIG. 26

SINGLE-LANCE REEL FOR INTERNAL CLEANING AND INSPECTION OF TUBULARS

RELATED APPLICATIONS

[0001] None.

FIELD OF THE INVENTION

[0002] This disclosure is directed generally to technology useful in tubular cleaning operations in the oil and gas exploration field, and more specifically to cleaning and inspecting the internals of tubulars such as drill pipe, workstring tubulars, and production tubulars.

BACKGROUND OF THE INVENTION

[0003] Throughout this disclosure, the term “Scorpion” or “Scorpion System” refers generally to the disclosed Thomas Services Scorpion brand proprietary tubular management system as a whole.

[0004] In conventional tubular cleaning operations, the cleaning apparatus is typically stationary, while the tubular is drawn longitudinally past the cleaning apparatus. The tubular is rotated at a relatively slow speed (in the range of 50 rpm, typically) while stationary, spring-loaded air motors drive spinning wire brushes and cutter heads on the inside diameter of the tubular as it is drawn past, via skewed drive rolls. These air brushes are colloquially called “cutters” although they perform abrasive cleaning operations on the internal surface of the tubular. Internal tubular cleaning operations typically also include hydroblasting in the prior art, although this is conventionally understood to be supplemental to the wire brush cleaning described above, rather than a primary cleaning process in and of itself. Typically this conventional hydroblasting is a low pressure water or steam pressure wash at pressures ranging from about 2,500 psi to 3,500 psi.

[0005] Good examples of conventional tubular cleaning apparatus are marketed by Knight Manufacturing, Inc. (formerly Hub City Iron Works, Inc.) of Lafayette, La. These products can be viewed on Knight’s website.

[0006] One drawback of conventional tubular cleaning apparatus is that, with the cleaning apparatus stationary and the tubular drawn longitudinally across, the apparatus requires a large building. Range 3 drilling pipe is typically 40-47 feet long per joint, which means that in order to clean range 3 pipe, the building needs to be at least approximately 120 feet long

SUMMARY OF THE INVENTION

[0007] Aspects of the Scorpion System disclosed and claimed in this disclosure address some of the above-described drawbacks of the prior art. In preferred embodiments, the Scorpion System rotates the tubular to be cleaned (hereafter, also called the “Work” in this disclosure) while keeping the Work stationary with respect to the cleaning apparatus. The Scorpion then moves the cleaning apparatus up and down the length of the Work while the Work rotates.

[0008] In currently preferred embodiments, the Work is typically rotated at speeds in a range of about 400-500 rpm, and potentially up to 1,750 rpm under certain criteria. By contrast, the Work may also be rotated as slowly as 0.01 rpm in such currently preferred embodiments, in order to facilitate high resolution local cleaning, inspection or data gathering/analysis. However, nothing in this disclosure should be inter-

preted to limit the Scorpion System to any particular rotational speed of the Work. Currently preferred embodiments of the Scorpion System further draw the cleaning apparatus up and down the length of the Work at speeds within a range of about 0.5 to 5.0 linear feet per second (“fps”), depending on the selected corresponding rotational speed for the Work. Again, nothing in this disclosure should be interpreted to limit the Scorpion System to any particular speed at which the cleaning apparatus may move up or down the length of the Work.

[0009] The Scorpion System provides a multi-lance injector assembly (MLI) to clean the internal surface of the Work. The MLI provides a series of extendable and retractable lances that move up and down the internal surface of the Work as it rotates. Each lance provides tool hardware to perform a desired lance function. Examples of lance functions may include, individually or in combinations thereof, and without limitation: hydroblasting, steam cleaning, washing and rinsing, high and low volume compressed air blowing, gas drying (such as nitrogen drying), rattling head cutters, abrasive cleaning, brushing, API drift checking, sensor or other data acquisition (including visual video inspection, thermal imaging, acoustic examination, magnetic resistivity examination and electromagnetic flux examination). Data acquisition may be in the form of static or streaming data acquisition. Lances may have amplifiers on board to boost sensed or generated signals. The MLI enables extension and retraction of individual lances, one at a time, in and out of the Work. The MLI further enables a user-selected sequence of internal surface cleaning and related operations by moving different lances, according to the sequence, into and out of position for extension and retraction in and out of the Work.

[0010] Tool hardware on any particular lance may provide for single or shared operations on the lance. For example, in some exemplary embodiments, data acquisition regarding the condition of the internal surface of the Work may be via sensors provided on tool hardware shared with cleaning operations. In other embodiments, the MLI may provide a lance dedicated to data acquisition.

[0011] Similarly, in some exemplary embodiments, API drift checking may be advantageously combined with other operations on a single lance. Running an API-standard drift on a lance in and out of the Work is useful not only to check for dimensional compliance of the Work with API standards, but also to locate and hold other operational tool hardware in a desired position relative to the Work as the lance extends and retracts. Especially on larger diameter Work, it may be advantageous (although not required within the scope of this disclosure) to attach a drift-like assembly to other lance tooling in order to accomplish several advantages. A drift or drift-like assembly: (1) protects more fragile internal parts of the lance and drift mechanisms; (2) minimizes friction, especially in view of the rotational speed of the Work; and (3) keeps the lance stabilized and positioned correctly inside the Work.

[0012] In a currently preferred embodiment, the MLI provides four (4) separate lances for internal surface cleaning and related operations. Nothing in this disclosure, however, should be interpreted to limit the MLI to any particular number of lances. In the currently preferred embodiment, the four lances are provided with tooling to accomplish the following exemplary operations:

[0013] Lance 1: High pressure water blast for concrete removal and general hydroblasting operations, or steam cleaning, especially on severely rusted or scaled interior surfaces of the Work.

[0014] Lance 2: Low pressure/high temperature wash, for general tubular cleaning operations, including salt wash and rust inhibitor coating.

[0015] Lance 3: Steel Wire Brushes and/or rattling/cutter head abrasive treatment.

[0016] Lance 4: Data probes, sensors, thermal imaging devices or specialized still/video camera probes.

[0017] Referring to Lance 3 in more detail, rotating steel wire brushes and/or steel rattling heads are provided for further internal surface cleaning after high pressure and/or low pressure washing phases. In another embodiment, data sensors may be deployed instead to share Lance 2 with the above described low pressure/hot wash function. In another alternative embodiment, high or low volume compressed air or nitrogen may be deployed to Lance 3 for drying and/or expelling debris. The compressed air may also supply pneumatic tools deployed on the lance.

[0018] Yet further alternative embodiments may deploy a variety of inspection hardware on various of the lances. For example, acoustic sensors may be deployed for sonic inspection. Magnetic resistivity sensors and magnetic flux sensors (such as a hall effect sensor) may be deployed for magnetic flux inspection. Amplifiers may be deployed to boost signals.

[0019] The range of inspection options envisioned in various embodiments of the MLI is varied. For example, visual inspection via video or still cameras may identify and analyze lodged objects in the wall of the Work in real time. Geometry and circularity of the Work may be measured and tagged in real time. Visual inspection video or still cameras may also be used to examine areas of interest on the internal wall of the Work more closely. Such areas of interest may be identified and tagged by visual examination, or by other examination (earlier or at the same time) by, for example, thermal imaging, acoustic analysis or magnetic flux/resistivity analysis. Such areas of interest may include loss in tubular wall thickness, or other conditions such as pitting, cracking, porosity and other tubular wall damage.

[0020] It will be further appreciated that inspection and examination data acquired during MLI operations may also be coordinated (either in real time or later) with other data acquired regarding the Work at any other time. In particular, without limitation, inspection and examination data may be, for example, (1) coordinated with earlier data regarding the Work to provide a history on the Work, or (2) coordinated in real time with comparable data obtained concurrently regarding the exterior surface of the Work to provide a yet more detailed and high resolution analysis of the state of the Work. The scope of this disclosure is not limited in this regard.

[0021] Again, nothing in this disclosure should be interpreted to limit the MIA lances to be assigned any specific tooling to perform any specific operations. Any lance may perform any operation(s) per user selection, and may deploy any tooling suitable to perform such user-selected operation(s).

[0022] In currently preferred embodiments of the Scorpion System, the lances provided by the MLI are not self-propelling up and down within the interior of the Work. The lances are moved up and down the interior of the Work as further described in this disclosure. However, nothing in this disclosure should be interpreted to limit the lances to a non-self-

propelling embodiment. Other embodiments within the scope of this disclosure may have full or partial lance propulsion functionality, including propulsion apparatus that gains traction on the interior surface of the Work.

[0023] It is therefore a technical advantage of the disclosed MLI to clean the interior of pipe efficiently and effectively. By extending and retracting interchangeable tooling on multiple lances into and out of a stationary but rotating tubular, considerable improvement is available for speed and quality of internal cleaning of the tubular over conventional methods and structure.

[0024] A further technical advantage of the disclosed MLI is to reduce the footprint required for industrial tubular cleaning. By extending and retracting lances into and out of a stationary tubular, reduced footprint size is available over conventional cleaning systems that move a tubular over stationary cleaning apparatus. Some embodiments of the MLI may be deployed on mobile cleaning systems.

[0025] A further technical advantage of the disclosed MLI is to enhance the scope, quality and reliability of inspection of the interior of the tubular before, during or after cleaning operations. Data acquisition structure may be deployed on one or more of the extendable or retractable lances. Such data acquisition structure may scan or nondestructively examine the interior of the tubular, either while the tubular is rotating or otherwise. Such data acquisition structure may include sensors, specialized visual inspection probes (such as video cameras), and/or thermal imaging probes.

[0026] The foregoing has outlined rather broadly some of the features and technical advantages of the present invention in order that the detailed description of the invention that follows may be better understood. Additional features and advantages of the invention will be described hereinafter which form the subject of the claims of the invention. It should be appreciated by those skilled in the art that the conception and the specific embodiment disclosed may be readily utilized as a basis for modifying or designing other structures for carrying out the same purposes of the present invention. It should be also be realized by those skilled in the art that such equivalent constructions do not depart from the spirit and scope of the invention as set forth in the appended claims.

BRIEF DESCRIPTION OF THE DRAWINGS

[0027] For a more complete understanding of the present invention, and the advantages thereof, reference is now made to the following descriptions taken in conjunction with the accompanying drawings, in which:

[0028] FIG. 1 is a functional cross-section view of aspects of one embodiment of the MLI;

[0029] FIG. 2 is a cross-section view as shown on FIG. 1;

[0030] FIG. 3 is an isometric view of aspects of embodiments of the MLI;

[0031] FIG. 4 is a general enlargement of MLI assembly 100 as illustrated on FIG. 3;

[0032] FIGS. 5 and 6 are exploded views of aspects also illustrated on FIG. 4;

[0033] FIG. 7 is an isometric view of aspects of embodiments of KJL assemblies 103 in isolation;

[0034] FIGS. 8, 9, 10 and 11 illustrate aspects and features of embodiments of KJL assemblies 103;

[0035] FIGS. 12 and 13 are isometric views illustrating aspects of embodiments of MLI assembly 100 and embodiments of adjustment assembly 120 in more detail;

[0036] FIGS. 14, 15, 16, 17, 18, 19, 20 and 21 illustrate aspects and features of embodiments of MLG assemblies 150;

[0037] FIG. 22 is an elevation view of embodiments of SLR assembly 190_S and MLR assembly 190_M;

[0038] FIGS. 23, 24 and 25 are isometric views of embodiments of SLR assembly 190_S and MLR assembly 190_M; and

[0039] FIG. 26 is an isometric view of aspects of an embodiment of MLR axle assembly 193_M.

DETAILED DESCRIPTION

[0040] Reference is now made to FIGS. 1 through 13 and FIGS. 8 through 11 in describing the currently preferred embodiment of the MLI.

[0041] It will be understood that the MLI, in a currently preferred embodiment, has a number of cooperating parts and mechanisms, including the Knuckle Jointed Lancer (KJL). FIGS. 1 and 2 are a functional cross-sectional representation of some of the main components included in a currently preferred embodiment of the MLI, and depict how such components cooperate in the MLI assembly. As functional representations, they will be understood not to be to scale even in a general sense. Rather, it will be appreciated that a primary purpose of FIGS. 1 and 2 is to illustrate cooperating aspects of the MLI in a conceptual sense (rather in a more structurally accurate sense), in order to facilitate better understanding of other, more structurally accurate illustrations of the MLI and KJL in this disclosure.

[0042] FIG. 1 illustrates MLI assembly 100 generally in cross-section, and depicts MLI assembly as generally comprising guide tube 101, stabbing guide tube 102, Knuckle Jointed Lancer (hereafter “KJL”) 103, stinger 104, hose 105, tooling head 106 and stabbing wheels 107. In FIG. 1, MLI assembly is shown operable to clean the internal surface of tubular W. Tubular W is shown on FIG. 1 as longitudinally stationary but rotating, per earlier material in this disclosure.

[0043] With further reference to FIG. 1, KJL 103 provides stinger 104 and tooling head 106 at one end. KJL is operable to be “stabbed” into and out of rotating tubular W. It will be understood that by stabbing KJL 103 in and out of the entire internal length of rotating tubular W while tubular W rotates, MLI assembly 100 enables cleaning tools and other functional devices on tooling head 106 (such tools and devices not individually illustrated on FIG. 1) to clean, inspect, sense or otherwise perform work on the entire internal length of tubular W.

[0044] Stabbing wheels 107 on FIG. 1 enable KJL 103 to be stabbed in and out of tubular W. It will be appreciated from FIG. 1 that guide tube 101 and stabbing guide 102 generally encase KJL 103 up until the general area where stinger 104 and tooling head 106 lead the “stabbing” (that is, the extension and retraction) of KJL 103 into and out of tubular W. Stabbing guide 102 provides gaps G where the outside surface of KJL 103 is exposed. In a currently preferred embodiment, gaps G are rectangular openings in stabbing guide 102, although this disclosure is not limited in this regard. Directional arrows 108A and 108B on FIG. 1 represent where stabbing wheels 107 are operable to be moved together and apart so that, via gaps G, the circumferences (or “treads”) of stabbing wheels 107 can engage and disengage the outer surface of KJL 103 on opposing sides. Thus, when stabbing wheels 107 are engaged on the outer surface of KJL 103 and rotated, per directional arrows 109A and 109B on FIG. 1, they become operable to move KJL 103 per directional arrow 110.

[0045] With further reference to FIG. 1, KJL 103 and stinger 104 encase 105. Hose 105 on FIG. 1 is a functional representation of any type of flexible supply that tooling on tooling head 106 may require, such as, purely for example, steam hoses, water hoses, air hoses, nitrogen gas hoses, or conduits comprising electrical power supply cords, data transfer wiring, solid conductors, coils or antennae. Nothing in this disclosure shall be interpreted to limit hose 105 to any particular type of flexible supply or combination thereof.

[0046] Discussing hose 105 in more detail, in currently preferred embodiments, the hoses are designed and manufactured for extended life in high temperature and high pressure service, and further comprise a customized armor system for protection on the outside, including an outer co-flex, stainless steel wall with flexible steel armoring and rigidity packing. The rigidity packing uses heat-shrinking material to form a solid ID-OD fusion bond in the hoses, while also filling the void between the outer armor system and the specially-designed high temperature and high pressure hoses. It will be appreciated, however, that these hose specifications are exemplary only, and that nothing in this disclosure should be interpreted to limit hose 105 on FIG. 1 to a particular specification.

[0047] It will be further understood that in embodiments where hoses 105 are specified per the example above for extended hose service life, the cost per unit length of the high-specification hose is significantly higher than the corresponding cost of conventional hose. In order to optimize this increased cost, hose 105 on FIG. 1 may, in some alternative embodiments, provide a connector separating a portion of conventional hose from a portion of higher specification hose. Advantageously, the portion of high-specification hose is positioned within KJL 103 and stinger 104 at the distal end thereof, connected to tooling head 106, and is long enough so that when KJL 103 is extended all the way to the very far (distal) end of tubular W, the entire length of tubular W is served by high-specification hose. The remaining portion of hose 105 will then be understood to be resident in the portion of KJL 103 that remains in guide tube 101 even when KJL 103 is extended all the way to the very far end of tubular W. This remaining portion of hose 105 may be deployed as conventional hose since it is not subject to the rigors of service within tubular W.

[0048] Although FIG. 1 illustrates a single hose 105 deployed in KJL 103, it will be appreciated that this disclosure is not limited to any particular number of hoses 105 that may be deployed in a single KJL 103. Multiple hoses 105 may be deployed in a single KJL 103, according to user selection and within the capacity of a particular size of KJL 103 to carry such multiple hoses 105. This “multiple hose 105 per KJL 103” aspect of MLI 100 is described in greater detail further on in this disclosure, with reference to FIG. 14.

[0049] With reference now to graphical separator A-A on FIG. 1, it will be appreciated that the portion of KJL 103 to the right of A-A on FIG. 1 is in cross-section, while the portion to the left is not. FIG. 1, to the left of graphical separator A-A, thus illustrates that a portion of the length of KJL 103 comprises a concatenated and articulated series of hollow, generally trapezoidal KJL segments 111. KJL segments 111 (and their generally trapezoidal profile) will be described in detail further on in this disclosure. However, it will be seen from FIG. 1 that the concatenated, articulated nature and general trapezoidal profile of KJL segments 111 allow KJL 103, when the distal end thereof is being stabbed in and out of tubular W,

to correspondingly slide around curved portions of guide tube **101** with reduced bending stress.

[0050] FIG. 2 is a cross-sectional view as shown on FIG. 1. Items depicted in both FIGS. 1 and 2 have the same numeral.

[0051] It will be immediately seen on FIG. 2 that, consistent with earlier material in this disclosure, a preferred embodiment of MLI assembly **100** provides 4 (four) separate and independent lances for cleaning, inspection, data acquisition and related operations (although as noted above, nothing in this disclosure should be construed to limit MLI assembly **100** to four lances). On FIG. 2, stabbing guide **102** includes upper and lower stabbing guide pieces **102U** and **102L**, which may be held together by conventional fasteners such as bolts and nuts. Stabbing guide **102** further encases 4 (four) separate KJL **103** assemblies. Each KJL **103** encases a hose **105**. It will be understood that KJL **103**, stinger **104** (not illustrated on FIG. 2), hose **105** and tooling head **106** (also not illustrated on FIG. 2) are functionally the same for each of the 4 (four) lance deployments illustrated on FIG. 2. It will be further appreciated that the disclosure above associated with FIG. 1 directed to extension and retraction of a single KJL **103** applies in analogous fashion to additional KJL assemblies **103** deployed on a particular embodiment of MLI assembly **100**.

[0052] As also mentioned above with reference to FIG. 1, it will be appreciated that although FIG. 2 illustrates a single hose **105** deployed in each KJL **103**, it will be appreciated that this disclosure is not limited to any particular number of hoses **105** that may be deployed in any single KJL **103**. Multiple hoses **105** may be deployed in any single KJL **103**, according to user selection and within the capacity of a particular size of KJL **103** to carry such multiple hoses **105**. This multi-hose **105** and multi-size KJL **103** aspect of MLI **100** is described in greater detail further on in this disclosure, with reference to FIG. 14.

[0053] Although not illustrated on FIGS. 1 and 2, currently preferred embodiments of guide tubes **101** and stabbing guide **102** provide a low-friction coating on the internal surface thereof. This low-friction coating assists a sliding movement of KJL **103** through guide tubes **101** and stabbing guide **102** as KJL **103** is extended and retracted into and out of tubular W.

[0054] FIG. 2 also shows stabbing wheels **107**. Consistent with FIG. 1, directional arrow **108A/B** on FIG. 1 represents where stabbing wheels **107** are operable to be moved together and apart so that, via gap G (not shown on FIG. 2), the circumferences (or “treads”) of stabbing wheels **107** can engage and disengage the outer surface of KJL **103** on opposing sides. Directional arrows **109A** and **109B** on FIG. 2 represent, consistent with FIG. 1, that rotation of stabbing wheels **107** when engaged on the outer surface of KJL **103** will cause KJL **103** to extend and retract.

[0055] Directional arrow **108C** on FIG. 2 represents that when stabbing wheels **107** are disengaged, stabbing guide **102** (or, in other embodiments, stabbing wheels **107**) is/are further operable to be moved laterally to bring any available KJL **103**, according to user selection, between stabbing wheels **107**. In this way, any available KJL **103**, according to user selection, may be called up for engagement by stabbing wheels **107** and subsequent extension into and retraction out of tubular W.

[0056] Directional arrows H and V on FIG. 2 represent generally that the entire MLI assembly **100** as described on FIGS. 1 and 2 may be adjusted horizontally and vertically to

suit size (diameter), wall thickness and relative position of tubular W into which KJL **103** assemblies are to be inserted. Such adjustment allows MLI assembly **100** to work on a wide range of different sizes and thicknesses of tubulars W.

[0057] With reference now to FIG. 3, a more scale-accurate representation of MLI assembly **100** is illustrated. Items depicted on FIG. 3 that are also depicted on FIGS. 1 and 1B have the same numeral. FIG. 3 depicts tubular W with a partial cutout, allowing KJL **103** (with stinger **104** and tooling head **106** on the distal end of KJL **103**) to be seen extending into nearly the entire length of rotating tubular W. FIG. 3 further depicts guide tube **101** and stabbing guide **102**.

[0058] Adjustment assembly **120** on FIG. 3 enables the positional adjustments described above with reference to FIGS. 1 and 2. More specifically, adjustment assembly **120** includes structure that enables (1) stabbing wheels **107** to move together and apart per directional arrows **108A** and **108B** on FIGS. 1 and 2, (2) stabbing guide **102** to move laterally per directional arrow **108C** on FIG. 2, and (3) MLI assembly **100** to move horizontally and vertically per directional arrows H and V on FIG. 2.

[0059] Although adjustment assembly **120** (and components thereof) are illustrated and describe generally in this disclosure, it will be appreciated that the specifics of adjustment assembly **120**, and the control thereof, rely on conventional hydraulic, pneumatic or electrical apparatus, much of which has been omitted from this disclosure for clarity.

[0060] FIG. 3 further illustrates hose box **121**. It will be appreciated that as KJL assemblies **103** are fully extended all the way to the distal end of tubular W, and then retracted all the way out of tubular W, corresponding hoses **105** deployed inside KJL assemblies **103** require surplus length to accommodate such extension and retraction. Hose box **121** is a containment box for such surplus lengths of hoses **105**.

[0061] FIG. 4 is a general enlargement of MLI assembly **100** as illustrated on FIG. 3, particularly in the area around stabbing guide **102**. Adjustment assembly **120** and tubular W on FIG. 3 have been omitted on FIG. 4 for clarity. As in other illustrations in this disclosure depicting aspects of MLI assembly **100**, items depicted on FIG. 4 that are also depicted on FIG. 1, 2 and/or 3 have the same numeral.

[0062] FIG. 4 illustrates stabbing guide **102** with one exemplary KJL **103** extended. Gaps G from FIG. 1 can also be seen on stabbing guide **102** on FIG. 4. It will be recalled from earlier disclosure describing FIG. 1 that the “treads” of stabbing wheels **107** (not shown on FIG. 4) contact the outer surface of KJL assemblies **103** through gaps G to enable, via rotation of stabbing wheels **107**, extension and/or retraction of KJL assemblies **103**.

[0063] FIG. 4 further illustrates guide tubes **101** as assemblies operable to be disassembled and reassembled. This aspect of guide tubes **101** enables, in part, MLI assembly **100** to be configured in either “curved tube” mode (as illustrated on FIG. 4) or “straight tube” mode (not illustrated) as further described below. It will be seen on FIG. 4 that in currently preferred embodiments, guide tubes **101** are separable along their travelling horizontal axis (or thereabouts) and are further operably held together during service with guide tube fasteners **122**. Longitudinal sections of guide tubes **103** are further separable at guide tubes joints **123** (only one exemplary guide tube joint **123** fully illustrated on FIG. 4).

[0064] It will be seen from FIG. 4 that optimization of footprint of MLI assembly **100** may be assisted by deploying guide tubes **101** as illustrated in FIG. 4, with guide tubes **101**

undergoing a u-turn of approximately 180 degrees at bend B during their travel. Although also not illustrated in FIG. 4, nothing in this disclosure should be construed to limit bend B to a u-turn of 180 degrees or thereabouts. Other angles of bend B are considered within the scope of this disclosure.

[0065] Other embodiments of the MLI assembly **100** (such other embodiments not illustrated) provide guide tubes **101** substantially straight, extending substantially horizontally up to the entrance to tubular W, and substantially parallel to the longitudinal axis of tubular W. It will be appreciated that such “straight tube” embodiments will require additional footprint. Some of such “straight tube” embodiments may also substitute rigid pipes for KJL assemblies **103**. With momentary reference to FIG. 1, rigid pipes in “straight tube” embodiments (not illustrated) will surround hoses **105** instead of KJL assemblies **103** and stingers **104**, and will further connect directly to tooling heads **106**. It will be appreciated that extension and retraction of the rigid pipes may then be enabled via stabbing wheels **107** operating on the exterior surfaces of rigid pipes through gaps G in stabbing guide **102**, per FIG. 1).

[0066] With reference now to FIGS. 5 and 6, guide tubes **101** and stabbing guide **102** are shown in partially “exploded” form in order to illustrate how certain embodiments of MLI assembly **100**, now to be illustrated and described in more detail, may be “converted” back and forth, per user selection, between a “curved tube” mode (as illustrated in FIG. 4), and a “straight tube” mode as described above although not illustrated. As before, items depicted on FIGS. 5 and 6 that are also depicted on FIGS. 1 through 4 have the same numeral.

[0067] It will be recalled from earlier disclosure referring to FIG. 4 that “convertible” embodiments of MLI assembly **100** provide guide tubes **101** operable to be disassembled and reassembled in order to convert between “curved tube” and “straight tube” modes. FIG. 5 illustrates MLI assembly **100** in “curved tube” mode, with guide tube **101** and stabbing guide **102** disassembled at guide tube joints **123**. It will be seen in the exemplary embodiment illustrated on FIG. 5 that two guide tube joints **123** are provided, one at the connection between guide tubes **101** and stabbing guide **102**, and the other at a connection between pieces of guide tubes **101** above stabbing guide **102**. It will be nonetheless understood that the number and location of guide tube joints **123** illustrated on FIG. 5 are exemplary only. Nothing in this disclosure should be interpreted to limit MLI assembly **101** to any particular number or location of guide tube joints **123**.

[0068] FIG. 6 illustrates MLI assembly **100** in “curved tube” mode with upper and lower stabbing guide pieces **102U** and **102L** separated. As noted above with reference to FIG. 4, fasteners **122** may hold sections of guide tube **101** and stabbing guide **102** together at the traveling horizontal axis thereof. In such an embodiment, fasteners **122** may be unfastened in order enable disassembly. It will be appreciated with referenced to FIG. 6 that although not illustrated, sections of guide tubes **101** may also be separated at their traveling horizontal axis by unfastening fasteners **122** in analogous fashion to the manner in which FIG. 6 illustrates stabbing guide pieces **102U** and **102L** as separated.

[0069] By way of reference, with FIG. 6 illustrating stabbing guide pieces **102U** and **102L** as separated, FIG. 6 further illustrates KJL assemblies **103**, stingers **104**, tooling heads **106**, KJL segments **111** and gaps G in more scale-accurate fashion than on FIGS. 1 and 1B, where they were illustrated in more of a functional form.

[0070] Visualizing FIGS. 5 and 6 together, therefore, it will be appreciated that by disassembling and separating guide tubes **101** at their traveling horizontal axes per FIG. 6, and by separating pieces thereof at guide tube joints **123** per FIG. 5, guide tubes **101** may be disassembled and removed from MLI assembly **100**.

[0071] Disassembly and removal of guide tubes **101** in turn exposes KJL assemblies **103** along their entire length, as illustrated on FIG. 7. As before, items depicted on FIG. 7 that are also depicted on FIGS. 1 through 6 have the same numeral. FIG. 7 further illustrates KJL assemblies **103** comprising KJL segments **111**. In more detail, it will be recalled from earlier disclosure with reference to FIG. 1 that KJL assemblies **103** each comprise a concatenated and articulated series of hollow, generally trapezoidal KJL segments **111**.

[0072] Referring back now to the general “conversion” procedure between “curved tube” and “straight tube” modes, it will be appreciated that FIG. 7 illustrates KJL assemblies **103** in “curved tube” mode. It will be further visualized from FIG. 7 that by following directional arrows **130**, the articulated, generally trapezoidal nature of concatenated KJL segments **111** enables KJL assemblies **103** to be laid out horizontally straight from their previous “curved tube” configuration (per FIG. 7) once guide tubes **101** are disassembled and removed. It will be then understood that KJL assemblies **103** will be in “straight tube” configuration once laid out straight and horizontal. Rigid pipes (per earlier disclosure) or straight guide tubes in pieces (not illustrated) may then be installed around straight and horizontal KJL assemblies **103**. MLI assembly **100** will then be in “straight tube” mode.

[0073] It will be appreciated that conversion back to “curved tube” mode requires generally the reverse process. KJL assemblies **103**, in straight and horizontal configuration are exposed by removal of their surrounding rigid pipes or straight guide tubes. The articulated, generally trapezoidal nature of concatenated KJL segments **111** enables KJL assemblies **103** to be “rolled over” in the opposite direction of directional arrows **130** on FIG. 7. When “rolled over” to the user-desired bend B (per FIG. 7), KJL assemblies **103** will be in “curved tube” configuration. Guide tubes **101** may be reassembled around KJL assemblies **103** per the reverse of the disassembly process described above with reference to FIGS. 5 and 6. MLI assembly **101** will then be “curved tube” mode again.

[0074] FIGS. 8 and 9 illustrate, in conceptual and functional form, the preceding two paragraphs’ disclosure of the currently preferred embodiment of “conversion” back and forth, per user selection, of “curved tube” and “straight tube” modes. As before, items on FIGS. 8 and 9 also shown on FIGS. 1 through 7 have the same numeral. On FIG. 8, with further reference to FIG. 7, MLI assembly **100** is in “curved tube” mode with KJL **103** curved around bend B. Stinger **104** and tooling head **106** are shown conceptually on FIGS. 8 and 9 for reference. FIGS. 8 and 9 further show, again conceptually and functionally rather than to scale, that KJL **103** comprises a concatenated string of articulated, generally trapezoidal KJL segments **111**.

[0075] By following directional arrow **130** on FIG. 8, KJL **103** may be laid out flat and horizontal as shown on FIG. 9. The concatenated string of articulated, generally trapezoidal KJL segments **111** enables KJL to be laid out flat and horizontal, in configuration for “straight tube” mode.

[0076] FIG. 9 further shows that by following directional arrow **130R** (the reverse of directional arrow **130** on FIG. 8),

KJL 103 may be “rolled up” again to form bend B, as shown on FIG. 8. The concatenated string of articulated, generally trapezoidal KJL segments 111 enables KJL 103 to be rolled up, in configuration for “curved tube” mode.

[0077] The articulated, generally trapezoidal nature of KJL segments 111 will now be discussed in greater detail. FIG. 10 illustrates a currently preferred design of an individual KJL segment 111. As before, items on FIG. 10 also shown on FIGS. 1 through 9 have the same numeral.

[0078] It will be understood that FIG. 10 illustrates just one example of a design of a KJL segment 111. Many types of individual design of KJL segments 111 are available within the scope of this disclosure, and the design of KJL segment 111 on FIG. 10 is exemplary only. Likewise, the size (diameter), number and length of individual KJL segments 111 in a particular KJL 103 may be per user design according to curvature and other geometric parameters of a particular MLI deployment. Nothing in this disclosure should be interpreted to limit the MLI to any particular length, size (diameter), number or even uniformity of KJL segments 111 that may be included in KJL 103.

[0079] Referring now to FIG. 10, KJL segment 111 provides pins 139 at one end (one pin hidden from view) and lug holes 140 at the other end. By linking the pins 139 of one KJL segment 111 into the lug holes 140 of the next in line, a plurality of KJL segments 111 may be concatenated into an articulated string, as illustrated in FIGS. 8 and 9, and elsewhere in this disclosure.

[0080] KJL segment 111 on FIG. 10 also has opposing longitudinal outer surfaces 111_I and 111_O which, when a plurality of KJL segments 111 are articulated together into a string thereof, will form the inner and outer surfaces of curvature respectively of the rolled-up articulated string. KJL segment 111 on FIG. 10 further provides opposing faces 111_F . Opposing faces 111_F are configured to slope towards one another. This sloping is illustrated on FIG. 10 at items 141A and 141B, where the planes of faces 111_F are illustrated to have angular deviation from a theoretical face plane that would be normal to the longitudinal axis of the KJL segment 111. In this way, the length of KJL segment 111 is less along longitudinal surface 111_I than it is along longitudinal surface 111_O . Accordingly, when a plurality of KJL segments 111 are articulated into a string such that longitudinal surfaces 111_I and 111_O line up along the string, the shorter lengths of surfaces 111_I permit “rolling up” where surfaces 111_I form the innermost surface of curvature, and surfaces 111_O form the outermost surfaces of curvature.

[0081] FIG. 11 illustrates KJL 103 comprising a concatenation of articulated KJL segments 111 designed per the example of FIG. 10. As before, items on FIG. 11 that are also shown on FIGS. 1 through 10 have the same numeral.

[0082] As described above with reference to FIG. 10, FIG. 11 shows that by linking the pins 139 of one KJL segment 111 into the lug holes 140 of the next in line, a plurality of KJL segments 111 may be concatenated into an articulated string. Further, the shorter lengths of longitudinal surfaces 111_I over longitudinal surfaces 111_O enable curvature when KJL 103 is “rolled up” so that surfaces 111_I form the innermost surface of curvature, and surfaces 111_O form the outermost surfaces of curvature.

[0083] For the avoidance of doubt, it is important to emphasize that although this disclosure has described immediately above (with reference to FIGS. 5 through 11) the optional feature on some MLI embodiments to “convert” between

“curved tube” and “straight tube” modes, this disclosure is not limited to such “convertible” embodiments. Other embodiments may be deployed permanently in “curved tube” or “straight tube” modes.

[0084] FIGS. 12 and 13 illustrate adjustment assembly 120 (also shown on FIG. 3) in more detail. As before, items shown on FIGS. 12 and 13 that are also shown on any other MLI-series or KJL-series illustration in this disclosure have the same numeral.

[0085] The primary difference between FIGS. 12 and 13 is that in FIG. 12, stabbing guide 102 is present, whereas in FIG. 13, it is removed. FIGS. 12 and 13 should be viewed in conjunction with FIGS. 1 and 2.

[0086] It will be recalled from earlier disclosure that FIGS. 1 and 2 illustrate, in a functional representation rather than a more scale-accurate representation, the operation of stabbing wheels 107 to enable extension and retraction of KJL 103 into and out of tubular W. FIGS. 1 and 2 further illustrate (again more in a functional sense than in a scale-accurate sense), by means of directional arrows 108A, 108B, 108C, 109A, 109B, 110, H and V, the manner in which stabbing wheels 107 may extend and retract KJL 103, and further, the manner in which MLI 100 may be adjusted positionally (1) to select a particular KJL 103 to be extended and retracted into and out of tubular W, and (2) to set a horizontal and vertical positions of the selected KJL 103 to suit location, diameter and wall thickness of tubular W. FIGS. 12 and 13 illustrate similar disclosure, except in a more scale-accurate representation, and further with reference to adjustment assembly 120.

[0087] Looking first at FIG. 12, it will be seen that adjustment assembly 120 comprises stabbing wheels 107. The “treads” of each stabbing wheel 107 will be understood to be engaged, through gaps G in stabbing guide 102, on the outside surface of KJL 103 (hidden from view by stabbing guide 102). Adjustment assembly 120 may move stabbing wheels 107 together and apart in the direction of arrows 108A/B as shown on FIG. 12 in order to engage/disengage KJL 103 through gaps G. Once stabbing wheels 107 are disengaged, adjustment assembly 120 may also move stabbing guide 102 (and connected guide tubes 101) laterally in the direction of arrow 108C in order to bring a selected KJL 103 into position between stabbing wheels 107 for further extension and retraction operations. Further, adjustment assembly 120 may move the entire MLI assembly 100 in this area in the direction of arrows H and V in order to suit location, diameter and wall thickness of a particular tubular W (not illustrated).

[0088] The immediately preceding paragraph disclosed that, in accordance with currently preferred embodiments of adjustment assembly 120, lateral movement of stabbing guide 102 enables a selected KJL 103 to be brought into position between stabbing wheels 107. This disclosure is not limited in this regard, however. Other embodiments of adjustment assembly 120 (not illustrated) may move stabbing wheels 107 laterally, or move both stabbing guide 102 and stabbing wheels 107 laterally, in order to bring a selected KJL 103 into position between stabbing wheels 107.

[0089] Turning now to FIG. 13, the “treads” of stabbing wheels 107 may now be seen engaged on the outer surface of KJL 103. Adjustment assembly 120 may cause stabbing wheels 107 to rotate in the direction of arrows 109A and 109B in order to extend and retract KJL 103.

[0090] It will be appreciated that, with reference to FIGS. 12 and 13, adjustment assembly 120 may be configured to extend or retract KJL assemblies 103 in a range of sizes. In

fact, nothing in this disclosure should be interpreted to limit KJL assemblies **103** (and corresponding KJL segments **111**) to any particular size or length. While FIGS. **1** and **2** above illustrate a single hose **105** deployed in each KJL **103**, it will be appreciated that this disclosure is not limited to any particular number of hoses **105** that may be deployed in a single KJL **103**. Multiple hoses **105** may be deployed in any KJL **103**, according to user selection and within the capacity of a particular size of KJL **103** to carry such multiple hoses **105**.

[0091] FIG. **14** illustrates an exemplary suite of 4 (four) KJL segments **111A** through **111D** in a range of sizes (diameters) and corresponding lengths. Each of KJL segments **111A** through **111D** conform to the general geometry and general concatenation concepts described above with reference to FIGS. **10** and **11**. Although FIG. **14** illustrates individual, single KJL segments **111A-D**, it will be appreciated that multiples of each of KJL segments **111A-D** may be concatenated into KJL strings that are functionally and operationally equivalent to the KJL assemblies **103** illustrated and described elsewhere in this disclosure.

[0092] Earlier disclosure with reference to FIGS. **1** and **2** described generally the concept that multiple hoses **105** may be deployed in a single KJL **103**. FIG. **14** shows that as the size (diameter) of KJL segments **111A-D** increases, the corresponding internal capacity thereof increases, making a concatenated string thereof increasingly suitable to carry more than one hose **105** (hoses **105** omitted for clarity on FIG. **14**).

[0093] The Scorpion System MLI contemplates a wide variety of hoses (and corresponding tooling at the distal end thereof) being available to MLI **100** for internal cleaning, inspection, data acquisition and other operations. Exemplary lances in a preferred embodiment are described above. Hoses suitable to serve such lances include (by way of example only, and without limitation): high volume air hoses for pneumatic tooling; high pressure water; steam; high temperature water; and conduits (e.g. pvc plastic) for data lines, electrical power lines, solid conductors, coils or antennae.

[0094] KJL **111A** on FIG. **14** is illustrated as having the largest size (diameter) of the suite of KJL segments **111A-D**. In currently preferred embodiments, KJL **111A** is about 4 inches in diameter. This 4-inch diameter allows for an internal diameter with capacity to carry several hoses. The precise number capable of being carried will depend on the user's selection of diameter of hoses.

[0095] KJL segments **111B**, **111C** and **111D** are illustrated as progressively smaller in size (diameter) than KJL segment **111A**, and will, again dependent on user selection, be capable of carrying correspondingly, fewer hoses each.

[0096] Generally, users are likely to select KJL size (diameter) according to the tooling intended to be deployed at the distal end of the KJL. Multiple hoses carried by a particular KJL will enable deployment of a multi-tool head at the distal end. Alternatively, multiple hoses carried in a particular KJL may be connected and disconnected to suit tooling at the distal end of the KJL as needed.

[0097] In addition to number of hoses, users are further generally likely to select KJL size (diameter) according to the size (diameter) of hose(s) intended to be carried. Larger size (diameter) hoses may be preferable in long KJL assemblies in order to mitigate pressure loss and/or flow rate loss over the length of the hose. Similarly, larger size (diameter) conduits may be preferable in long KJL assemblies in order to carry larger diameter cables, which are less susceptible to voltage drop, current losses, or signal losses over greater length.

[0098] Further reference to FIG. **14** shows that in preferred embodiments, the length of KJL segments **111A-D** changes inversely with respect to the size (diameter). A primary reason, again in preferred embodiments, is manufacturing economy. With reference now to FIG. **7**, it will be appreciated that the manufacturing costs of a concatenated KJL assembly **103** for a particular size (diameter) will increase with the number of articulated KJL segments **111** that are deployed in the concatenated string. It is preferable, for manufacturing economy, to make the length of individual KJL segments **111** as long as possible in order to reduce the number of KJL segments **111** that will require concatenation. However, the concatenated string must still be able to be extended and retracted around bend B without undue bending stress.

[0099] Referring now to FIG. **14** again, it will be appreciated that the smaller the size (diameter) of KJL segments **111A-D**, the more receptive to bending an individual KJL segment is likely to be when a concatenation thereof is extended and retracted around bend B (from FIG. **7**). Thus, again in preferred embodiments, such smaller-sized (smaller-diameter) KJL segments may be manufactured with a longer distance between the articulations in a concatenation thereof. Hence such smaller-sized (smaller diameter) KJL segments may be manufactured to be greater in length.

[0100] As previously noted, FIG. **14** illustrates an exemplary suite of 4 (four) KJL segments **111A** through **111D**, in which KJL segments **111A-D** decrease in size (diameter) moving from **111A** through to **111D**, and correspondingly increase in length. Nothing in this disclosure should be interpreted, however, to limit the Scorpion System MLI to such an arrangement. According to user selection and design, a particular deployment of the Scorpion System MLI may have any number of KJL assemblies, in any arrangement of size (diameter) and associated length.

[0101] It will be appreciated that when the Scorpion System MLI is configured with a suite of KJL assemblies of differing size (diameter) and corresponding differing KJL segment length, guide tubes **101** and stabbing guide **102** (as illustrated on FIGS. **5** and **6**, for example) may become more complex to manufacture, assemble and disassemble. Accordingly, the Scorpion System MLI provides the Multi-Lance Guide (MLG) as an optional, alternative embodiment for such deployments of multi-size KJL assemblies. In such embodiments, the MLG generally substitutes for guide tubes **101** and stabbing guide **102**.

[0102] FIG. **14** illustrates Multi-Lance Guide (MLG) **150**, comprising MLG tube **151** and MLG interior **152**. MLG interior **152** provides MLG apertures **153** in corresponding size and number to match concatenated strings of KJL segments **111A** through **111D**. The diameters of each of MLG apertures **153** are pre-selected to slideably receive their corresponding concatenated string of KJL segments **111A-D**, as applicable.

[0103] FIG. **15** illustrates MLG **150** where, by comparison to FIGS. **5** and **6**, for example, MLG **150** will be seen to be suitable to generally substitute for guide tubes **101** and stabbing guide **102** to hold and guide KJL assemblies **103** (not illustrated on FIG. **15**) during extraction and retraction operations. Nothing in this disclosure, however, should be interpreted to require (or favor) an embodiment comprising MLG **150** over an embodiment comprising guide tubes **101** and stabbing guide **102**, or vice versa. This disclosure is not limiting in this regard.

[0104] As shown on FIG. 15, MLG 150 comprises MLG straight sections 150_S, MLG curved sections 150_C and MLG stabbing guide 150_{SG}. Each of 150_S, 150_C and 150_{SG} further comprise MLG tube 151 and MLG interior 152 (or, more precisely, sections thereof). As noted immediately above with reference to FIG. 14, and as now can be seen further on FIG. 15, MLG interior 152 provides MLG apertures 153 throughout in size and number to slideably receive a corresponding suite of user-selected KJL assemblies 103 (not illustrated on FIG. 15).

[0105] FIG. 15 further shows that a plurality of MLG straight sections 150_S and MLG curved sections 150_C may be concatenated and then joined to MLG stabbing guide 150_{SG} to create MLG 150 per user selection and design. Concatenation of straight sections 150_S and curved sections 150_C (and then to MLG stabbing guide 150_{SG}) may be by conventional methods, such as (for example) fastening with bolts. Such exemplary concatenation fastening apparatus has been omitted for clarity on FIG. 15 (and on other illustrations in this disclosure) for MLG straight sections 150_S and MLG stabbing guide 150_{SG}, but may be seen on FIG. 15 for MLG curved sections 150_C.

[0106] FIG. 15 further depicts gap G in MLG stabbing guide 150_{SG}. Referring back momentarily to disclosure associated with FIG. 12, gaps G on top of and underneath MLG stabbing guide 150_{SG} (gap G underneath hidden from view on FIG. 15) are operable to allow stabbing wheels 107 (as shown on FIG. 12) to engage KJL assemblies 103 deployed inside MLG stabbing guide 150_{SG}.

[0107] FIG. 15 also illustrates MLG feet 154, whose function is to enable the entire MLG 150 assembly to slide unrestrained over supporting structural steel (omitted for clarity) during Scorpion System MLI operations. It will be recalled from earlier disclosure that preferred embodiments of the Scorpion System MLI enable users to select from among two or more (and preferably four) KJL assemblies in deciding which KJL assembly to extend and retract into a tubular. It will be further recalled from disclosure associated with FIG. 12 that adjustment assembly 120 enables movement in the direction of arrows H, V and 108C in order to position a particular KJL assembly with respect to a tubular. Referring now to FIG. 15 again, it will be appreciated that sliding movement of MLG feet 154 over supporting structural steel (omitted for clarity) enables overall displacement of MLG 150 to accommodate corresponding movement and displacement when a user selects a particular KJL assembly to be positioned for extension/retraction into and out of a tubular (per FIGS. 12 and 13 and associated disclosure). MLG feet 154 may be of any conventional construction, such as (for example) ball bearings or ball races enclosed in metal or plastic housings.

[0108] FIGS. 16 and 17 illustrate MLG straight section 150_S (from FIG. 15) in greater detail. As also noted above with reference to FIG. 15, conventional structure (such as bolts or other fasteners) disposed to enable concatenation of multiple MLG straight sections 150_S has been omitted from FIGS. 16 and 17 for clarity. FIG. 16 illustrates MLG straight section 150_S comprising MLG tube 151 encasing MLG interior pieces 152_A and 152_B (which together comprise MLG interior 152 as illustrated on FIGS. 14 and 15). FIG. 16 also depicts MLG apertures 153, which have been described in greater detail above with reference to FIGS. 14 and 15.

[0109] Referring now to FIGS. 16 and 17 together, it will be seen that in currently preferred embodiments, MLG interior

pieces 152_A and 152_E are two mirror-image halves disposed to be joined horizontally to form MLG interior 152. This currently preferred embodiment simplifies the manufacture of MLG interior 152, enabling the fabrication of long, straight sections of MLG interior pieces 152_A and 152_B that include substantially precise semi-circular cutouts for MLG apertures 153 over the entire length. The need for precise drilling of MLG apertures 153 over the entire length of MLG interior 152 is thus obviated.

[0110] In currently preferred embodiments, MLG interior 152 is made of Ultra-High Molecular Weight (UHMW) plastic throughout MLG 150 (including MLG straight sections 150_S, MLG curved sections 150_C and MLG stabbing guide 150_{SG}). This UHMW plastic material is hard and robust, yet suitable for machining and related operations to create MLG apertures 153 in fully assembled MLG interiors 152. The UHMW plastic material is further low-friction and self-lubricating, and also relatively hard-wearing, enabling KJL assemblies received in MLG apertures 153 to slide operably therethrough during extension and retraction operations.

[0111] With further reference to FIGS. 16 and 17, it will be understood that MLG straight sections 150_S are assembled by receiving MLG interior pieces 152_A and 152_B into MLG tube 151. MLG interior pieces 152_A and 152_E may be secured in MLG tube 151 by conventional methods, such as (for example) bolts, screws or other fasteners. All of such securing structure has been omitted for clarity on FIGS. 16 and 17. However, it will be appreciated that by using fasteners for such securing structure, MLG interior pieces 152_A and 152_E are interchangeable within MLG tubes 151. MLG interior pieces 152_A and 152_E may thus be changed out in individual MLG straight sections 150_S if they become damaged or worn. Similarly, if the user desires to change the configuration of KJL sizes (diameters) deployed within MLG 150, then MLG interior pieces 152_A and 152_E may be changed out throughout to provide corresponding receiving MLG apertures 153.

[0112] FIGS. 18 and 19 illustrate MLG curved section 150_C (from FIG. 15) in more detail. FIG. 19 depicts MLG curved section 150_C viewed from the direction of arrow 170 as shown on FIG. 18. The component parts of MLG curved section 150_C depicted on FIG. 18 are also depicted on FIG. 19 from this alternative view. It will be seen immediately from FIGS. 18 and 19 that conceptually, with its generally trapezoidal profile, MLG curved section 150_C is analogous in form and function to KJL segment 111 as illustrated on FIG. 10. For this reason, it may be helpful to read the following disclosure making reference to FIGS. 18 and 19 in association with earlier disclosure making reference to FIG. 10.

[0113] As with KJL segments 111 on FIG. 10, the intent of the generally trapezoidal profile of MLG curved section 150_C on FIGS. 18 and 19 is to enable a concatenated string of MLG curved sections 150_C to follow a curved path, as illustrated on FIG. 15. Accordingly, with reference to FIG. 18, MLG curved section 150_C comprises MLG tube 151 with opposing MLG tube sides 151_I and 151_O. MLG tube side 151_I is shorter in longitudinal length than tube side 151_O in order to give MLG curved section 150_C its generally trapezoidal profile. It will be appreciated that when multiple MLG curved sections 150_C are concatenated such that MLG tube sides 151_I mate together and tube sides 151_O mate together, a generally curved string thereof will result, as illustrated on FIG. 15.

[0114] Concatenation of MLG curved sections 150_C may be enabled by any suitable conventional structure. In currently preferred embodiments, as illustrated on FIGS. 18 and

19, each MLG curved section **150_C** provides MLG concatenation bolts **155**, MLG concatenation holes **156** and MLG concatenation lugs **157**. Concatenation is enabled in such embodiments by fastening the MLG concatenation bolts **155** through the MLG concatenation lugs **157** of a first MLG curved section **150_C** and into the MLG concatenation holes **156** of a second, neighboring MLG curved section **150_C**. Nothing in this disclosure should be construed, however, as limiting the concatenation of MLG curved sections **150_C** to the use of concatenation bolts, lugs and holes as illustrated on FIGS. **18** and **19**.

[0115] The actual overall size and trapezoidal profile dimensions of MLG curved sections **150_C** (and, indeed, the corresponding dimensions of MLG straight sections **150_S** and MLG stabbing guide **150_{SG}**) are all per user selection and design, according to the needs of a particular Scorpion System MLI (and associated MLG) deployment. Nothing herein should be construed to limit the Scorpion System to (or favor) a particular dimensional MLG design.

[0116] FIGS. **18** and **19** also illustrate currently preferred embodiments of MLG interior **152** for MLG curved section **150_C**. As with MLG straight section **150_S** (described above with reference to FIGS. **16** and **17**), MLG tube **151** for MLG curved section **150_C** on FIG. **18** encases MLG interior **152**. MLG interior **152** on FIG. **18** thus shares the general trapezoidal profile of MLG curved section **150_C** and associated MLG tube **151**. In distinction to MLG straight section **150_S** (described above with reference to FIGS. **16** and **17**), however, FIGS. **18** and **19** show that currently preferred embodiments call for the manufacture of MLG interior **152** for MLG curved section **150_C** from one solid piece of UHMW plastic, and further call for MLG apertures **153** provided in MLG interior **152** to be oblate or slotted rather than substantially circular.

[0117] By momentary reference to FIG. **15**, it will be appreciated that the shorter overall longitudinal length of a typical MLG curved section **150_C** enables MLG interior **152** to be manufactured from one UHMW plastic piece, since MLG apertures **153** may be more precisely drilled, reamed and otherwise machined through such a shorter length of UHMW plastic. It will be further appreciated by reference to FIGS. **18** and **19** that MLG apertures **153** are oblate or slotted in MLG, curved section **150_C** in order to accommodate the articulated series of straight edges that occurs when KJL assemblies deployed within MLG apertures **153** are in “curved tube” mode, per earlier disclosure making reference to FIGS. **8** and **11**.

[0118] It will be further recalled from FIG. **14** and associated disclosure that in currently preferred embodiments, smaller diameter KJL assemblies are preferably manufactured with longer longitudinal length in order to optimize manufacturing costs. It will thus be appreciated that when such smaller-diameter, longer-longitudinal-length KJL assemblies are in “curved tube” mode (per FIGS. **8** and **11** and associated disclosure), the resulting articulated series of straight edges is more pronouncedly “straight” (i.e. more a series of straight edges and less of a “curve”). This “more pronounced straight edge” effect in turn requires a correspondingly greater “slotting” of the MLG apertures **153** in MLG curved sections **150**, in order to slideably accommodate the straight edges of a KJL assembly in “curved tube” mode without undue bending.

[0119] It will be again understood that actual oblate or slotted dimensions of MLG apertures **153** in MLG curved

sections **150_C** are all per user selection and design, according to the needs of a particular deployment of KJL assemblies therein, in combination with the overall dimensional design of the MLG. Nothing herein should be construed to limit the MLG in this regard.

[0120] It will be further understood that MLG interior **152** may be secured in MLG tube **151** on MLG curved sections **150_C** by conventional methods, such as (for example) bolts, screws or other fasteners. All of such securing structure has been omitted for clarity on FIGS. **18** and **19**. However, it will be appreciated that by using fasteners for such securing structure, MLG interiors **152** are interchangeable within MLG tubes **151**. MLG interiors **152** may thus be changed out in individual MLG curved sections **150_C** if they become damaged or worn. Similarly, if the user desires to change the configuration of KJL sizes (diameters) deployed within MLG **150**, then MLG interiors **152** may be changed out throughout to provide corresponding receiving MLG apertures **153**.

[0121] FIGS. **20** and **21** are side-by-side comparisons of MLG **150** in “curved tube” and “straight tube” modes. Earlier material in this disclosure (for example, with reference to FIGS. **7** through **11**) describes embodiments of the Scorpion System MLI in “curved tube” and/or “straight tube” modes, according to user selection. Such material further describes embodiments in which KJL assemblies may be “converted” back and forth between “curved tube” and “straight tube” modes. FIGS. **20** and **21** illustrate “curved tube” and “straight tube” embodiments of MLG **150**, which may also be converted back and forth between modes in order to support the corresponding mode that the user selects for KJL assemblies deployed therein.

[0122] FIG. **21** is an enlargement of a portion of FIG. **20** as shown on FIG. **20**. Chained line **180** appears in both. FIGS. **20** and **21**, and serves to divide the illustrations functionally between “curved tube” mode (above chained line **180**) and “straight tube” mode (below chained line **180**).

[0123] Referring first to FIG. **20**, MLG **150** is illustrated in “curved tube” mode (above chained line **180**) substantially as illustrated in FIG. **15**. In this “curved tube” mode, MLG **150** comprises MLG straight sections **150_S**, MLG curved sections **150_C** and MLG stabbing guide **150_{SG}**, as previously illustrated. Further, MLG curved sections **150_C** have been concatenated as described above with reference to FIGS. **18** and **19**, wherein the general trapezoidal profiles of MLG curved sections **150_C** are aggregated into an overall generally curved concatenation thereof.

[0124] FIG. **20** also illustrates MLG **150** in “straight tube” mode (below chained line **180**). Again, MLG **150** comprises MLG straight sections **150_S**, MLG curved sections **150_C** and MLG stabbing guide **150_{SG}** in this “straight tube” mode. However, in this “straight tube” mode, MLG curved sections **150_C** have been concatenated such that their general trapezoidal profiles have been arranged to “cancel each other out” rather than aggregate into an overall general curve.

[0125] This “canceling out” aspect of a “straight tube” embodiment of MLG **150** is best viewed on FIG. **21**. Above chained line **180**, FIG. **21** illustrates the general trapezoidal profiles of MLG curved sections **150_C** arranged to aggregate into an overall general curve. Below chained line **180**, FIG. **21** illustrates the general trapezoidal profiles of MLG curved sections **150_C** arranged to oppose, or to “cancel each other out”, so that the concatenation of MLG curved sections **150_C** is in a straight line.

[0126] It thus will be appreciated that a concatenation of MLG curved sections 150_C may be “converted” back and forth between “curved tube” and “straight tube” modes by unfastening the concatenated sections, reversing the general trapezoidal aspect of every other section (i.e. “flipping it over”), and re-fastening. In such “convertible” embodiments, fastening structure should preferably be provided symmetrically to enable similar fastening whether in “curved tube” or “straight tube” modes. Also, with additional reference to FIGS. 18 and 19, before MLG curved sections 150_C are re-fastened, MLG interiors 152 of MLG curved sections 150_C that are reversed (or “flipped over”) may also need to be reversed (or “flipped over”) themselves in order to preserve continuity of MLG apertures 153 from one MLG curved section 150_C to the next. It will be seen from FIGS. 18 and 19 that reversal of MLG interiors 152 may be accomplished by unfastening and removing them from their MLG tubes 151 , reversing their orientation, and then re-fastening them into MLG tubes 151 .

[0127] Although not illustrated in any detail, it will be understood from FIG. 15 that MLG stabbing guide 150_{SG} is, in currently preferred embodiments, substantially a MLG straight section 150_S as illustrated and described in detail with reference to FIGS. 16 and 17. MLG stabbing guide 150_{SG} differs primarily from MLG straight section 150_S in that MLG stabbing guide 150_{SG} also provides gaps G (as described with reference to FIG. 15).

[0128] FIGS. 22 through 25 illustrate various views of Single Lance Reel (SLR) assembly 190_S and Multi-Lance Reel (MLR) assembly 190_M . FIG. 26 illustrates aspects and features of MLR axle assembly 193_M on MLR assembly 190_M in more detail. As throughout this disclosure, items depicted on FIGS. 22 through 26 that are also depicted on other FIGURES in this disclosure have the same numeral.

[0129] Embodiments of the Scorpion System deploying either SLR assembly 190_S or MLR assembly 190_M on FIGS. 22 through 25 enable concatenated strings of KJL assemblies 103 to be rolled and unrolled, as required, onto or off a rotary “reel”-like assembly as such KJL assemblies 103 are selectively retracted or extended in and out of tubular W. It will be appreciated the primary difference between SLR assembly 190_S and MLR assembly 190_M is that SLR assembly 190_S provides “reel”-like structure for rolling up and unrolling a single KJL assembly 103 , while MLR assembly 190_M provides “reel”-like structure for rolling up and unrolling multiple KJL assemblies 103 (each KJL assembly 103 capable of being rolled up or unrolled independently per user selection). FIGS. 22 through 26 illustrate embodiments of MLR assembly 190_M in which an example of four (4) KJL assemblies 103 are available to be independently rolled up or unrolled. Nothing in this disclosure should be interpreted, however, to limit MLR assembly 190_M to handling any particular number (two or more) of KJL assemblies 103 .

[0130] SLR assembly 190_S and MLR assembly 190_M are thus alternative embodiments to the earlier described functionality provided by MLG 150 (as illustrated on FIGS. 14 through 21), or guide tubes 101 (as illustrated on FIGS. 1 through 13). Instead of holding and positioning concatenated strings of KJL assemblies 103 in an enclosed structure (as in MLG 150 or guide tubes 101), SLR assembly 190_S and MLR assembly 190_M hold and position concatenated strings of KJL assemblies 103 by rolling them up onto a “reel”-like structure. As will be appreciated from FIGS. 22 through 25, therefore, embodiments deploying either SLR assembly 190_S or

MLR assembly 190_M obviate any need for “curved tube” and “straight tube” modes (such as were described above with reference to MLG 150 or guide tubes 101). In this way, embodiments deploying either SLR assembly 190_S or MLR assembly 190_M potentially permit substantial savings in footprint. Such SLR and MLR embodiments further simplify overall deployment of the Scorpion System by obviating the structural steel and other conventional infrastructure that, as described above (although not illustrated for clarity), is required to support and serve either MLG 150 or guide tubes 101 .

[0131] Turning first to FIG. 22, SLR assembly 190_S is illustrated with a concatenated string of KJL assemblies 103 substantially fully “rolled up” ready for extension thereof during internal cleaning, inspection or other operations. Substantially all of the structure of SLR assembly 190_S has been removed for clarity on FIG. 22 in order to enable better appreciation of the functional operation of SLR assembly 190_S (and, by association, MLR assembly 190_M). The embodiment of SLR assembly 190_S illustrated on FIG. 22 further shows depicts an embodiment of MLG stabbing guide 150_{SG} (refer FIG. 15) and an embodiment of adjustment assembly 120 (including stabbing wheels 107 , hidden from view, refer FIGS. 12 and 13) positioned and disposed, per earlier disclosure, to extend and retract the concatenated string of KJL assemblies 103 . It will be understood from the embodiment of SLR assembly 190_S illustrated on FIG. 22 that as stabbing wheels 107 on adjustment assembly 120 rotate and extend/retract KJL assemblies 103 , the “reel”-like structure provided by SLR assembly 190_S (omitted for clarity on FIG. 22 but depicted, for example, on FIG. 23) unrolls and rolls up in corresponding fashion to “pay out” and “take up” the concatenated string of KJL assemblies 103 .

[0132] FIG. 22 further illustrates MLR assembly 190_M , which, as noted, operates in conceptually and functionally the same manner as SLR assembly 190_S to “pay out” and “take up” any one of multiple concatenated strings of KJL assemblies 103 deployed thereon as such KJL assemblies 103 are extended/retracted independently per user selection. The embodiment of MLR assembly 190_M depicted on FIG. 22 is hiding the KJL assemblies 103 deployed thereon, but these KJL assemblies 103 may be seen by momentary reference to, for example, the view on FIG. 24. The embodiment of MLR assembly 190_M depicted on FIG. 22 illustrates MLR rim 191_M , MLR spokes 192_M and MLR axle assembly 193_M in elevation view and in general form.

[0133] Reference is now made to FIG. 23, depicting SLR assembly 190_S and MLR assembly 190_M in a perspective view. KJL assemblies 103 (shown on 24 and 22, for example) have been omitted from SLR assembly 190_S and MLR assembly 190_M on FIG. 23 for clarity. Among other features, FIG. 23 contrasts the multiple independent reel structure of MLR assembly 190_M with the single reel structure of SLR assembly 190_S . FIG. 23 also illustrates each of MLR assembly 190_M and SLR assembly 190_S having rims 191_M and 191_S , spokes 192_M and 192_S , and axle assemblies 193_M and 193_S (which features will be described in more detail further on in this disclosure).

[0134] In both MLR assembly 190_M and SLR assembly 190_S embodiments illustrated on 23, wheels 107 engage on KJL assemblies 103 via gap G in embodiments of MLG stabbing guide 150_{SG} (KJL assemblies 103 omitted on FIG. 23 for clarity, as noted above). Consistent with earlier disclosure associated with, for example, FIG. 1, rotation of wheels

107 causes KJL assemblies 103 to extend and retract into and out of tubular W. It will be understood from FIG. 22 and now FIG. 23 that as KJL assemblies 103 extend and retract into and out of tubular W, MLR and SLR assemblies 190_M and 190_S “pay out” and “take up” the concatenated string of KJL assemblies 103 using “reel”-like structure on which KJL assemblies 103 are unrolled and rolled up.

[0135] It will be further appreciated with reference to FIG. 23 that on MLR assembly 190_M, any selected one of the multiple strings of KJL assemblies 103 deployed thereon may be “paid out” and “taken up” independently of the other strings of KJL assemblies 103 also deployed thereon (such non-selected strings of KJL assemblies 103 remaining motionless while the selected one is “paid out” and/or “taken up”). MLR axle assembly 193_M, in conjunction with MLR rims 191_M and MLR spokes 192_M, provides structure to enable independent “paying out” or “taking up” of any string of KJL assemblies 103 deployed, and will be described in greater detail further on with reference to FIG. 26. This structure on MLR assembly 190_M enabling independent “paying out” or “taking up” of any string of KJL assemblies 103 deployed thereon enables MLR assembly 190_M to be compatible with earlier disclosure (see FIGS. 1, 2, 12 and 13 and associated disclosure including stabbing wheels 107 and adjustment assembly 120, for example) in which any one of multiple strings of KJL assemblies 103 may be user-selected at any particular time for extension into and retraction out of tubular W. It will be further understood that particularly with regard to MLR assembly 190_M, as adjustment assembly 120 moves concatenated strings of KJL assemblies 103 from side to side to bring a selected string thereof between stabbing wheels 107, MLR assembly 190_M may be disposed to make corresponding lateral movements.

[0136] FIG. 24 illustrates MLR and SLR assemblies 190_M and 190_S in similar fashion to FIG. 23, except enlarged and shown from a different perspective angle. FIG. 24 also shows concatenated strings of KJL assemblies 103 deployed on MLR and SLR assemblies 190_M and 190_S (such strings of KJL assemblies 103 omitted for clarity on FIG. 23). Disclosure above referring to FIGS. 22 and 23 applies equally with reference to FIG. 24.

[0137] FIG. 25 illustrates MLR and SLR assemblies 190_M and 190_S in similar fashion to FIG. 24, except shown from a different perspective angle. FIG. 25 further shows SLR assembly 190_S with parts of SLR rim 191_S removed so that KJL assemblies 103 can be seen more clearly deployed thereon.

[0138] The following disclosure regarding deployment of KJL assemblies 103 on SLR rim 191_S is also illustrative of corresponding deployment of each of the multiple KJL assemblies 103 acting independently on MLR rims 191_M, although such structure on MLR rims 191_M is hidden from view on FIG. 25. It will be seen on FIG. 25 that the first KJL assembly 103 in the concatenated string thereof is anchored to SLR rim 191_S with the distal end of the first KJL assembly 103 near any one of SLR spokes 192_S. Anchoring may be by any conventional removable anchoring structure, such as threaded bolts, for example, wherein KJL assemblies 103 may be periodically removed from SLR rim 191_S for maintenance. In preferred embodiments, SLR rim 191_S provides sidewalls whose spacing is selected to be wide enough to enable a string of KJL assemblies 103 to roll up and unroll comfortably between the sidewalls to permit a helical spooling. In this way, unwanted bending, twisting or shear stresses

on the couplings between individual KJL assemblies 103 are minimized as strings thereof are rolled up and unrolled. Other embodiments may provide SLR rim 191_S to be narrow enough for successive rolls of KJL assemblies 103 to stack vertically on top of each other rather than “sliding down” partially or completely side by side

[0139] Preferred embodiments of SLR assembly 190_S and MLR assembly 190_M as illustrated on FIG. 25 are advantageously sized so that approximately two (2) revolutions thereof will extend a string of KJL assemblies 103 from “fully rolled up” to “fully paid out” (and vice versa). Nothing in this disclosure should be interpreted, however, to limit the choice of size of SLR assembly 190_S and/or MLR assembly 190_M in this regard.

[0140] As noted above, it will be understood that, although not fully depicted on FIG. 25 (because MLR rims 191_M on MLR assembly 190_M are not partially removed on FIG. 25), the preceding disclosure regarding KJL assemblies 103 deployed on SLR assembly 190_S as shown on FIG. 25 is illustrative of each of the KJL assemblies 103 deployed on MLR assembly 190_M.

[0141] It will be further recalled from earlier disclosure that in preferred embodiments, KJL assemblies 103 encase at least one hose 105 that serves tooling head 106 on a distal end of each string of KJL assemblies 103. Refer back, for example, to FIGS. 1 and 14 with associated disclosure herein. Referring now to FIG. 25 again, it will be appreciated that in the illustrated embodiment, hose(s) 105 within KJL assemblies on SLR assembly 190_S terminate at SLR rim 191_S. SLR spoke hose(s) 194_S connect to hose(s) 105 at SLR rim hose connection 195_S and extend along a selected SLR spoke 192_S to SLR axle hose connection 196_S near or on SLR axle assembly 193_S.

[0142] It will be further appreciated that preferred embodiments of SLR assembly 190_S provide connection structure as described above and illustrated on FIG. 25 (including SLR rim hose connection 195_S, SLR spoke hose(s) 194_S and SLR axle hose connection 196_S) in order to facilitate maintenance and replacement of hose(s) 105 in KJL assemblies 103. Nothing in this disclosure should be interpreted to limit the type, location or manner of connection of hose(s) 105 across SLR assembly 190_S in other embodiments thereof.

[0143] With continuing reference to FIG. 25, SLR axle assembly 193_S comprises a conventional rotary union 197. A remote source or reservoir of fluids or other material to be carried and ultimately delivered by hose(s) 105 within KJL assemblies 103 may thus be connected to rotary union 197 on SLR axle assembly 193_S (such remote source/reservoir and connection omitted on FIG. 25 for clarity). The fluids or other material flow through rotary union 197 and into hose(s) 105 within KJL assemblies 103 via SLR axle hose connection 196_S, SLR spoke hose(s) 194_S and SLR rim hose connection 195_S.

[0144] FIG. 25 further illustrates SLR drive 198 on SLR assembly 190_S. SLR drive 198 may be any conventional drive mechanism, and this disclosure is not limited in this regard. In presently preferred embodiments of SLR assembly 190_S, SLR drive 198 is a direct drive.

[0145] SLR drive 198 is provided on SLR assembly 190_S to cooperate with stabbing wheels 107 in extending and retracting strings of KJL assemblies 103. In preferred embodiments, stabbing wheels 107 are the primary extending and retraction mechanism (see, for example, FIG. 1 and associated disclosure above). In embodiments deploying SLR assembly 190_S,

however, SLR drive **198** assists stabbing wheels **107** to keep mild tension in strings of KJL assemblies **103** as they are “rolled up” and “paid out”. SLR drive **198** may also provide additional power to assist stabbing wheels **107** with extension and retraction of KJL assemblies **103** when required.

[0146] It will be recalled from earlier disclosure that FIG. **25** shows SLR assembly **190_S** with parts of SLR rim **191_S** removed so that KJL assemblies **103**, hose(s) **105** and associated structure can be seen more clearly deployed thereon. The preceding disclosure regarding deployment of KJL assemblies **103** on SLR rim **191_S** and the structure connecting hose(s) **105** to SLR axle assembly **193_S** is also illustrative of corresponding deployment of each of the multiple KJL assemblies **103** and associated hoses **105** acting independently on MLR rims **191_M**, although such structure on MLR rims **191_M** is hidden from view on FIG. **25**. In preferred embodiments of MLR assembly **190_M**, although not specifically illustrated, each string of KJL assemblies **103** terminates near a selected MLR spoke **192_M**. Although again hidden from view, it will be understood that hose(s) **105** deployed within each string of KJL assemblies **103** are advantageously connected to MLR axle assembly **193_M** via MLR rim hose connections, MLR spoke hoses and MLR axle hose connection.

[0147] It will be further appreciated that, consistent with similar disclosure with respect to SLR assembly **190_S** above, preferred embodiments of MLR assembly **190_M** provide connection structure as described immediately above (including MLR rim hose connections, MLR spoke hoses and MLR axle hose connection identified above but hidden from view on FIG. **25**) in order to facilitate maintenance and replacement of hose(s) **105** in KJL assemblies **103**. Nothing in this disclosure should be interpreted to limit the type, location or manner of connection of hose(s) **105** across MLR assembly **190_M** in other embodiments thereof.

[0148] FIG. **26** illustrates features and components of an embodiment of MLR axle assembly **193_M** in more detail. By way of background, it will be appreciated from earlier disclosure that on MLR assembly **190_M**, each string of KJL assemblies **103** deployed thereon is free to be “paid out” or “taken up” independently according to user selection. It will be further recalled that in preferred embodiments (as illustrated on FIG. **25**, for example) four (4) independent strings of KJL assemblies **103** are deployed on a single MLR assembly **190_M**. A conventional rotary union, such as rotary union **197** disclosed above on SLR axle assembly **193_S**, is thus not operable for analogous deployment on MLR axle assembly **193_M** since up to four (4) independent supplies of fluids or other materials need to be carried independently and separately from their respective remote sources or reservoirs via MLR axle assembly **193_M** to a corresponding hose **105** within one of the independently extensible/retractable strings of KJL assemblies **103** deployed on MLR assembly **190_M**. A conventional rotary union will typically provide structure for only a single supply of fluid through the union.

[0149] FIG. **26** illustrates aspects of MLR axle assembly **193_M** in which, consistent with preferred embodiments illustrated elsewhere in this disclosure, four (4) separate and independent supplies of fluids or other materials may be carried through MLR axle assembly **193_M**. As noted earlier, this disclosure’s example to illustrate and describe MLR assembly **190_M** (and associated MLR axle assembly **193_M**) as providing four (4) separate and independent supplies of fluids or other materials to each of four (4) independently-operable

strings of KJL assemblies **103** is an exemplary embodiment only. Nothing in this disclosure should be interpreted to limit MLR assembly **190_M** (and MLR axle assembly **193_M**) to provide for more or fewer than four (4) separate and independently-operable strings of KJL assemblies **103**.

[0150] With continuing reference to FIG. **26**, MLR axle assembly **193_M** comprises stationary axle **161**, on which four (4) axle spools **162_A**, **162_B**, **162_C** and **162_D** are separated by spool seals **163**. Spool seals **163** may be any suitable seal between independently rotating parts, such as conventional swivel seals, and this disclosure is not limited in this regard. Axle spools **162_A**, **162_B**, **162_C** and **162_D** are each free to rotate separately and independently on axle **161**. Viewing FIGS. **22** and **26** together, it will be appreciated that MLR spokes **192_M** on FIG. **22** advantageously attach to MLR axle assembly **193_M** via bolting or other similar conventional means to axle spools **162_A**, **162_B**, **162_C** and **162_D**, as illustrated on FIG. **26**.

[0151] Referring again to FIG. **26**, axle **161** further comprises inlet ports **164_A** and **164_E** at one end, and inlet ports **164_C** and **164_D** at the other end. Axle spools **162_A**, **162_B**, **162_C** and **162_D** each provide a corresponding outlet port **165_A**, **165_B**, **165_C** and **165_D**. Inlet ports **164_A** through **164_D** each connect to a corresponding one of outlet ports **165_A** through **165_D** via individual and separate pathways through the interior of axle **161** and axle spools **162_A** through **162_D**, respectively (such pathways not illustrated). Such pathways may be of any convenient conventional design, such as drilling out each pathway in the core of axle **161** beginning at an inlet port **164_A** through **164_D**, and emerging in a radial direction at the circumference of axle **161** in line with the circumference of rotation above of the corresponding outlet port **165_A** through **165_D** on axle spools **162_A** through **162_D**. Each axle spool **162_A** through **162_D** may then provide a semi-circular (or other shaped profile) groove on its internal circumference in line with its corresponding outlet port **165_A** through **165_D**, and to which groove each corresponding outlet port **165_A** through **165_D** is connected. Such connection may, in some embodiments, include a semi-circular (or other shaped profile) annular groove around the outer circumference of axle **161** that coincides with the grooves on the internal circumference of axle spools **162_A** through **162_D** under outlet ports **165_A** through **165_D**. In such embodiments, the grooves on each surface (outer surface of axle **161** and internal surface of axle spools **162_A** through **162_D**) may combine to form a ring groove as part of the flow passageway between inlet ports **164_A** through **164_D** and corresponding outlet ports **165_A** through **165_D**. Rotary seals may be provided between axle **161** and axle spools **162_A** through **162_D** either side of the groove. In this way, fluids or other material may enter into a selected one of inlet ports **164_A** through **164_D** and exit out of a corresponding one of outlet ports **165_A** through **165_D**, via its drilled pathway in axle **161** and the sealed rotating groove under the corresponding one of axle spools **162_A** through **162_D**. Preferred embodiments may advantageously hold and pass fluids or other materials in and through the immediately foregoing pathway structure at pressures up to 20 kpsi.

[0152] With reference now to FIGS. **22** and **25** and associated disclosure above, and with continuing reference to FIG. **26**, it will be appreciated that outlet ports **165_A** through **165_D** may be connected to hose(s) **105** deployed within each string of KJL assemblies **103** deployed on MLR assembly **190_M** via MLR axle hose connections, MLR spoke hoses and MLR rim hose connections (such connection structure hidden from view on FIGS. **22** and **25**, but analogous to SLR axle hose

connection **196_S**, SLR spoke hose **194_S** and SLR rim hose connection **195_S** illustrated and described above with respect to SLR assembly **190_S** on FIG. 25). It will be therefore understood from the foregoing disclosure that each hose **105** deployed within each independently extendable and retractable string of KJL assemblies **103** deployed on MLR assembly **190_M** may be addressed and supplied with fluid (or other materials) via a corresponding designated stationary inlet port **164_A** through **164_D** located on axle **161**.

[0153] In exemplary embodiments, the drive structure on MLR assembly **190_M** provides separate and independently operable drives, such as conventional chain and sprocket drives or belt and pulley drives, to rotate each MLR rim **191_M** independently, in order to enable each corresponding string of KJL assemblies **103** to be extended or retracted independently, per user selection. It will be appreciated from the structure of MLR axle assembly **193_M** as illustrated on FIG. 26 that direct drive structure (such as suggested above for SLR drive **198** in preferred embodiments of SLR assembly **190_S** as illustrated on FIG. 25) is not optimal to provide independent drive structure to at least interior spools **162_B** and **162_C**. Conventional belt or chain drives are more suitable to drive at least interior spools **162_E** and **162_C**. Some embodiments of MLR **190_M** may provide direct drive structure to drive end spools **162_A** and **162_D** on MLR axle assembly **193_M**, while other embodiment may provide other conventional drives, such as belt or chain drives, on end spools **162_A** and **162_D**.

[0154] For the avoidance of doubt, it will be understood that throughout this disclosure, certain conventional structure has been omitted for clarity. For example, and without limitation, features of MLI assembly **100** are, in either “curved tube” or “straight tube” mode, advantageously supported by structural steel and other conventional support means, all of which has been omitted for clarity. Operation of MLI assembly **100** (including at adjustment assembly **120**) is advantageously accomplished using conventional hydraulic, pneumatic or electrical apparatus, all of which has been also omitted for clarity.

[0155] Currently preferred embodiments of MLI assembly **100** may further be controlled to operate in user-selected options of manual, semi-automatic and automatic modes. A paradigm for optimal Scorpion System operating efficiency includes being able to program the MLI to run automatically. That is, to repeat a cycle of tubular interior processing operations (including cleaning and data acquisition operations) as a series of tubulars **W** are automatically and synchronously: (1) placed into position at the beginning of the cycle, (2) ejected at the end of the cycle, and then (3) replaced to start the next cycle. In automatic mode, the user may specify the sequence of operations of KJL assemblies **103** in a cycle on each tubular **W**. The cycle of lance operations will then be enabled and controlled automatically, including insertion and retraction of KJL assemblies **103** in sequence in and out of the tubular **W**, with corresponding repositioning of guide tubes **101** and stabbing guide **102** with respect to tubular **W** between each lance operation. The cycle may be repeated in automatic mode, as tubulars **W** are sequentially placed into position. In semi-automatic mode, the operation may be less than fully automatic in some way. For example, a cycle may be user-specified to only run once, so that tubulars **W** may be manually replaced between cycles. In manual mode, the user may dictate each lance operation individually, and the MLI may wait for further instruction after each lance operation.

[0156] The Scorpion System as described in this disclosure is designed to achieve the following operational goals and advantages:

[0157] Versatility.

[0158] The Scorpion System as disclosed herein has been described with respect to currently preferred embodiments. However, as has been noted repeatedly in this disclosure, such currently preferred embodiments are exemplary only, and many of the features, aspects and capabilities of the Scorpion System are customizable to user requirements. As a result the Scorpion System is operable on many diameters of tubular in numerous alternative configurations. Some embodiments may be deployed onto a U.S. Department of Transport standard semi-trailer for mobile service.

[0159] Substantially Lower Footprint of Cleaning Apparatus.

[0160] As noted above, conventionally, the cleaning of range 3 drill pipe requires a building at least 120 feet long. Certain configurations of the Scorpion System can, for example, clean range 3 pipe in a building of about half that length. Similar footprint savings are available for rig site deployments. As also noted above, a mobile embodiment of the Scorpion System is designed within U.S. Department of Transportation regulations to be mounted on an 18-wheel tractor-trailer unit and be transported on public roads in everyday fashion, without requirements for any special permits.

[0161] Dramatically Increased Production Rate in Cleaning.

[0162] An operational goal of the Scorpion System is to substantially reduce conventional cleaning time. Further, the integrated yet independently-controllable design of each phase of cleaning operations allows a very small operator staff (one person, if need be) to clean numerous tubulars consecutively in one session, with no other operator involvement needed unless parameters such as tubular size or cleaning requirements change. It will be further understood that in order to optimize productivity, consistency, safety and quality throughout all tubular operations, the systems enabling each phase or aspect of such operations are designed to run independently, and each in independently-selectable modes of automatic, semi-automatic or manual operation. When operator intervention is required, all adjustments to change, for example, modes of operation or tubular size being cleaned, such adjustments are advantageously enabled by hydraulically-powered actuators controlled by system software.

[0163] Improved Quality of Clean.

[0164] It is anticipated that the Scorpion System will open up the pores of the metal tubular much better than in conventional cleaning, allowing for a more thorough clean. In addition, the high rotational speed of the tubular during cleaning operations allows for a thorough clean without a spiral effect even though cleaning may optionally be done in one pass.

[0165] Although the present invention and its advantages have been described in detail, it should be understood that various changes, substitutions and alternations can be made herein without departing from the spirit and scope of the invention as defined by the appended claims.

We claim:

1. A single-lance reel assembly, comprising:
 - a substantially cylindrical axle, the axle further comprising:
 - an external axle surface; and

- first and second transverse axle faces at corresponding first and second ends of the axle;
- a reel assembly received onto and disposed to rotate about the axle, the reel assembly further comprising:
- a rim;
 - a hub, the hub including a central circular hole into which the axle is received, the hole providing an internal hub surface opposing the external axle surface;
 - a hub hose connector on the hub; the hub hose connector in passageway communication with one of the first and second transverse axle faces via a hose supply passageway; and
 - a plurality of spokes separating the rim from the hub, the spokes attached at one end thereof to the hub and at the other end thereof to the rim;
- a hollow lance spooled onto the rim; and
- at least one hose deployed within the lance, each hose connected to the hub hose connector, each hose further in passageway communication with one of the transverse axle faces via the hose supply passageway.
- 2.** The single-lance reel assembly of claim **1**, in which the hose supply passageway is a rotary union deployed on the axle.
- 3.** The single-lance reel assembly of claim **1**, in which the hose supply passageway further comprises:
- a continuous circular hub groove in the internal hub surface;
 - a hub aperture connecting the hub groove with an external hub surface on the hub;
 - a continuous circular axle groove in the external surface of the axle, the axle groove located so that when the reel assembly is received onto the axle, the axle groove aligns with the hub groove to form a continuous ring aperture; and
 - an axle aperture connecting the axle groove with one of the first and second transverse axle faces.
- 4.** The single-lance reel assembly of claim **1**, in which the reel assembly further includes a rim hose connector in passageway communication with the hub hose connector via a spoke tube on one of the spokes, and in which each hose is in passageway communication with one of the transverse axle faces via the hose connector, the spoke tube, the hub hose connector and the hose supply passageway.
- 5.** The single-lance reel assembly of claim **3**, in which the axle further comprises at least one rotary seal proximate to the axle groove.
- 6.** The single-lance reel assembly of claim **3**, in which at least one of the hub groove and the axle groove has a semi-circular transverse profile.
- 7.** The single-lance reel assembly of claim **1**, in which the reel assembly is powered by a drive mechanism selected from the group consisting of:
- (1) a direct drive mechanism;
 - (2) a chain and sprocket drive mechanism; and
 - (3) a belt and pulley drive mechanism.
- 8.** A single-lance reel assembly, comprising:
- a substantially cylindrical axle, the axle further comprising:
 - an external axle surface;
 - first and second transverse axle faces at corresponding first and second ends of the axle; and
 - a rotary union deployed thereon;
 - a reel assembly received onto and disposed to rotate about the axle at the rotary union, the reel assembly further comprising:
 - a rim;
 - a hub, the hub including a central circular hole into which the axle is received, the hole providing an internal hub surface opposing the external axle surface;
 - a hub hose connector on the hub; the hub hose connector in passageway communication with one of the first and second transverse axle faces via the rotary union; and
 - a plurality of spokes separating the rim from the hub, the spokes attached at one end thereof to the hub and at the other end thereof to the rim;
 - a hollow lance spooled onto the rim; and
 - at least one hose deployed within the lance, each hose connected to the hub hose connector, each hose further in passageway communication with one of the transverse axle faces via the rotary union.
- 9.** The single-lance reel assembly of claim **8**, in which the reel assembly further includes a rim hose connector in passageway communication with the hub hose connector via a spoke tube on one of the spokes, and in which each hose is in passageway communication with one of the transverse axle faces via the hose connector, the spoke tube, the hub hose connector and the rotary union.
- 10.** The single-lance reel assembly of claim **8**, in which the reel assembly is powered by a drive mechanism selected from the group consisting of:
- (1) a direct drive mechanism;
 - (2) a chain and sprocket drive mechanism; and
 - (3) a belt and pulley drive mechanism.
- 11.** A single-lance reel assembly, comprising:
- A substantially cylindrical axle, the axle further comprising:
 - an external axle surface; and
 - first and second transverse axle faces at corresponding first and second ends of the axle;
 - a reel assembly received onto and disposed to rotate about the axle, the reel assembly further comprising:
 - a rim;
 - a hub, the hub including a central circular hole into which the axle is received, the hole providing an internal hub surface opposing the external axle surface;
 - a continuous circular hub groove in the internal hub surface;
 - a hub aperture connecting the hub groove with an external hub surface on the hub;
 - a hub hose connector on the hub; the hub hose connector in passageway communication with the hub aperture; and
 - a plurality of spokes separating the rim from the hub, the spokes attached at one end thereof to the hub and at the other end thereof to the rim;
 - a continuous circular axle groove in the external surface of the axle, the axle groove located so that when the reel assembly is received onto the axle, the axle groove aligns with the hub groove to form a continuous ring aperture;
 - an axle aperture connecting the axle groove with one of the first and second transverse axle faces;
 - a hollow lance spooled onto the rim; and
 - at least one hose deployed within the lance, each hose connected to the hub hose connector, each hose further

in passageway communication with one of the transverse axle faces via the hub aperture, the ring aperture and the axle aperture.

12. The single-lance reel assembly of claim **11**, in which the reel assembly further includes a rim hose connector in passageway communication with the hub hose connector via a spoke tube on one of the spokes, and in which each hose is in passageway communication with one of the transverse axle faces via the hose connector, the spoke tube, the hub hose connector, the hub aperture, the ring aperture and the axle aperture.

13. The single-lance reel assembly of claim **11**, in which the axle further comprises at least one rotary seal proximate to the axle groove.

14. The single-lance reel assembly of claim **11**, in which at least one of the hub groove and the axle groove has a semi-circular transverse profile.

15. The single-lance reel assembly of claim **11**, in which the reel assembly is powered by a drive mechanism selected from the group consisting of:

- (1) a direct drive mechanism;
- (2) a chain and sprocket drive mechanism; and
- (3) a belt and pulley drive mechanism.

* * * * *