



US 20150050867A1

(19) **United States**

(12) **Patent Application Publication**

**Thomas et al.**

(10) **Pub. No.: US 2015/0050867 A1**

(43) **Pub. Date: Feb. 19, 2015**

(54) **FLOATING BRUSH TRAIN FOR EXTERNAL CLEANING OF TUBULARS**

(52) **U.S. Cl.**

CPC ..... *B24B 27/033* (2013.01); *B24B 5/36* (2013.01); *B24B 27/0015* (2013.01); *B24B*

*27/0076* (2013.01)

USPC ..... **451/295**; **451/294**

(71) Applicant: **Thomas Engineering Solutions & Consulting, LLC**, New Iberia, LA (US)

(72) Inventors: **William C. Thomas**, Lafayette, LA (US); **William J. Thomas, III**, New Iberia, LA (US); **Perry J. DeCuir, JR.**, Rochester Hills, MI (US); **Kenny Perry, JR.**, Youngsville, LA (US)

(57)

**ABSTRACT**

Enhanced methods are disclosed for performing operations such as cleaning, inspection or data acquisition on an external surface of a hollow cylindrical tubular. Preferred embodiments include providing a fluid dispenser and an abrasion assembly on a buggy that travels up and down the length of the tubular as the tubular rotates. The fluid dispenser includes nozzles that dispense cleaning fluids onto the tubular's external surface. The abrasion assembly includes a swivel brush and a brush train providing different styles of abrasion cleaning of the tubular's external surface. Preferred embodiments of the buggy also carry a range finding laser and an optical camera generating samples that may be processed in real time into data regarding the surface contours and the diameter variations on the tubular's external surface. Cleaning and inspection variables such as tubular rotational speed, or buggy speed, may be adjusted responsive to measured surface contour data.

(21) Appl. No.: **14/527,616**

(22) Filed: **Oct. 29, 2014**

**Related U.S. Application Data**

(63) Continuation of application No. 14/042,683, filed on Sep. 30, 2013.

(60) Provisional application No. 61/799,425, filed on Mar. 15, 2013.

**Publication Classification**

(51) **Int. Cl.**

*B24B 27/033* (2006.01)

*B24B 27/00* (2006.01)

*B24B 5/36* (2006.01)

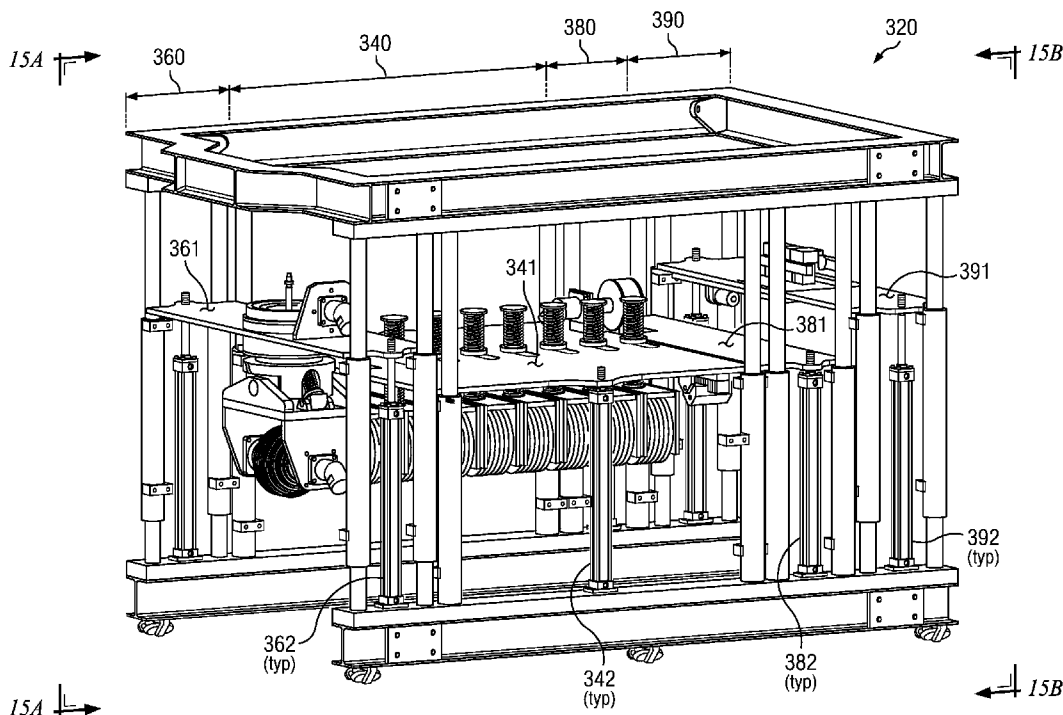

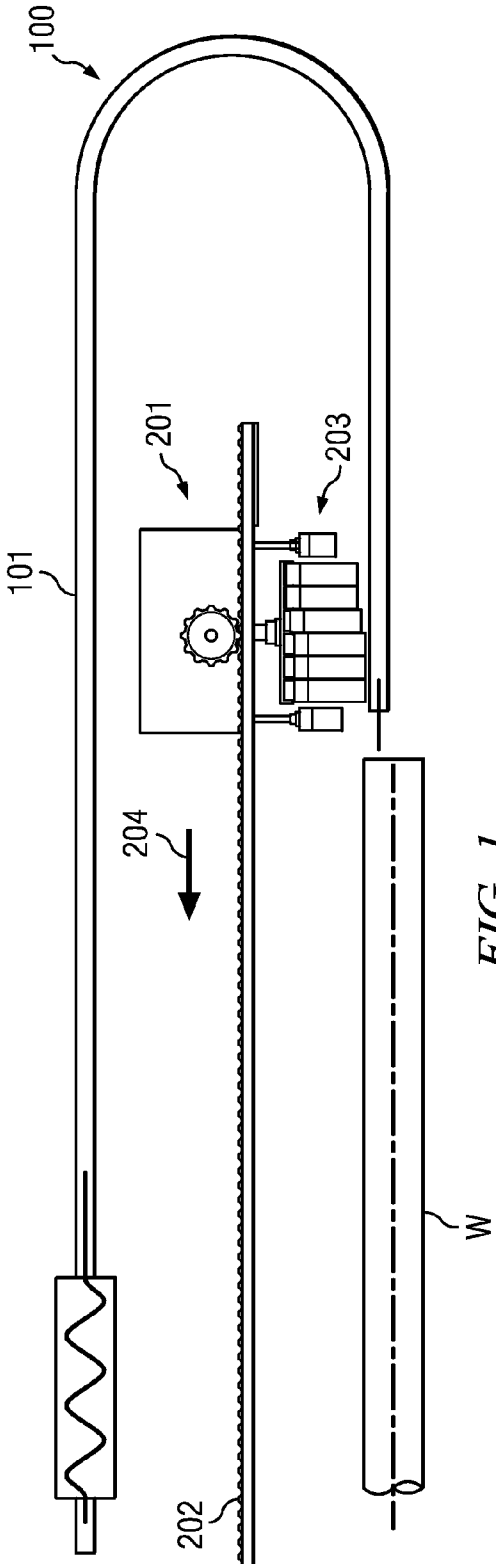
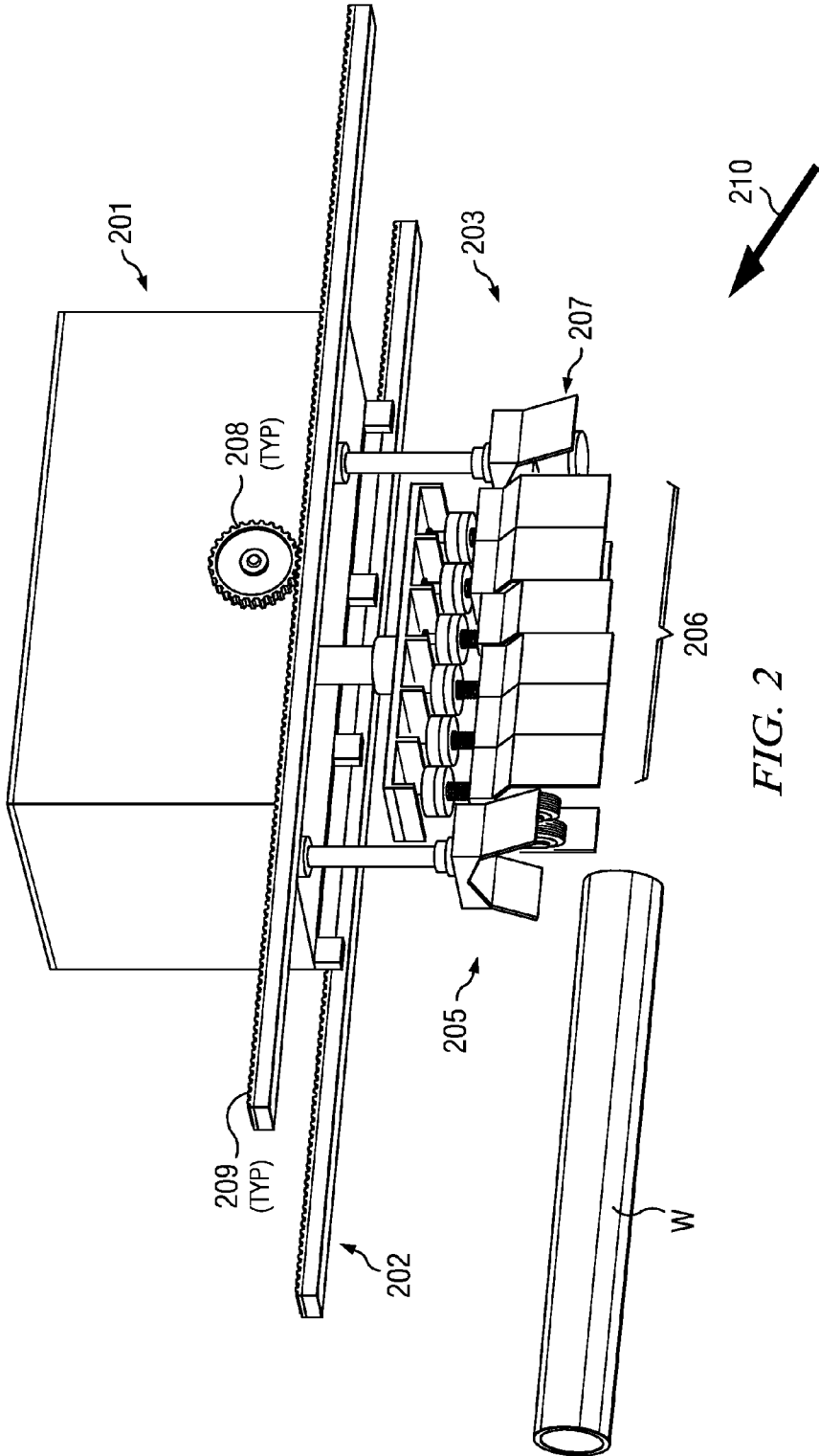

FIG. 1



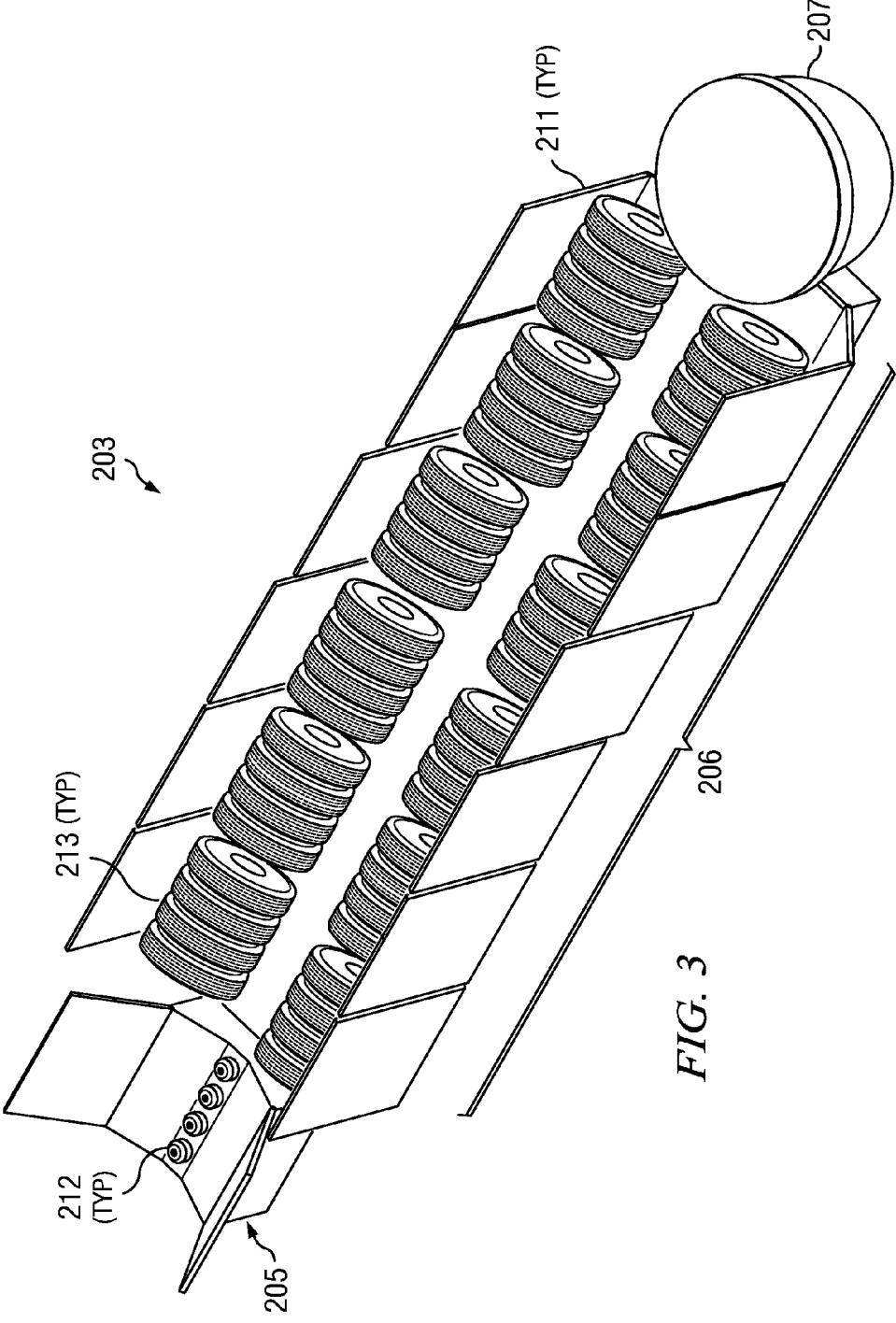

FIG. 3

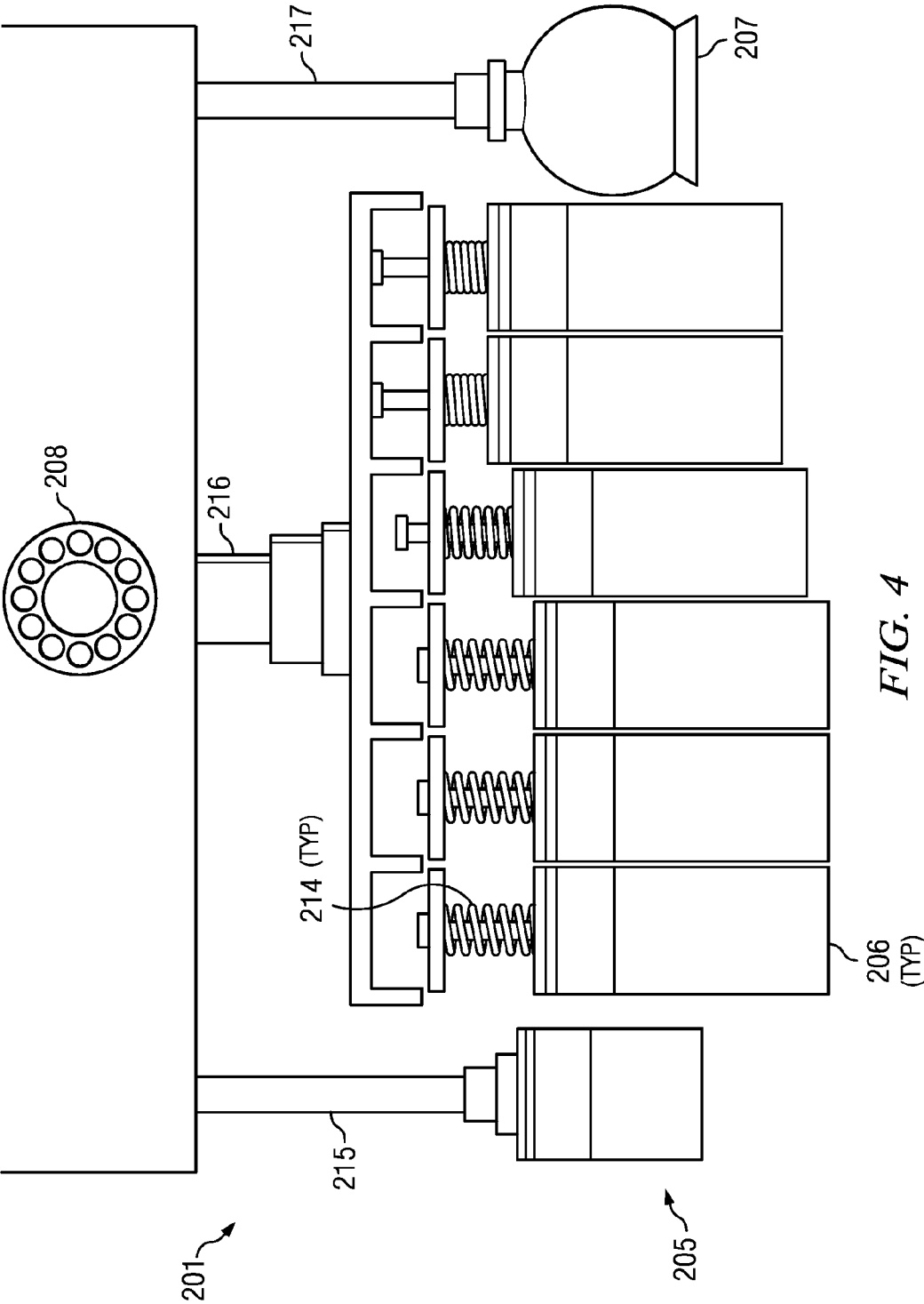

FIG. 4

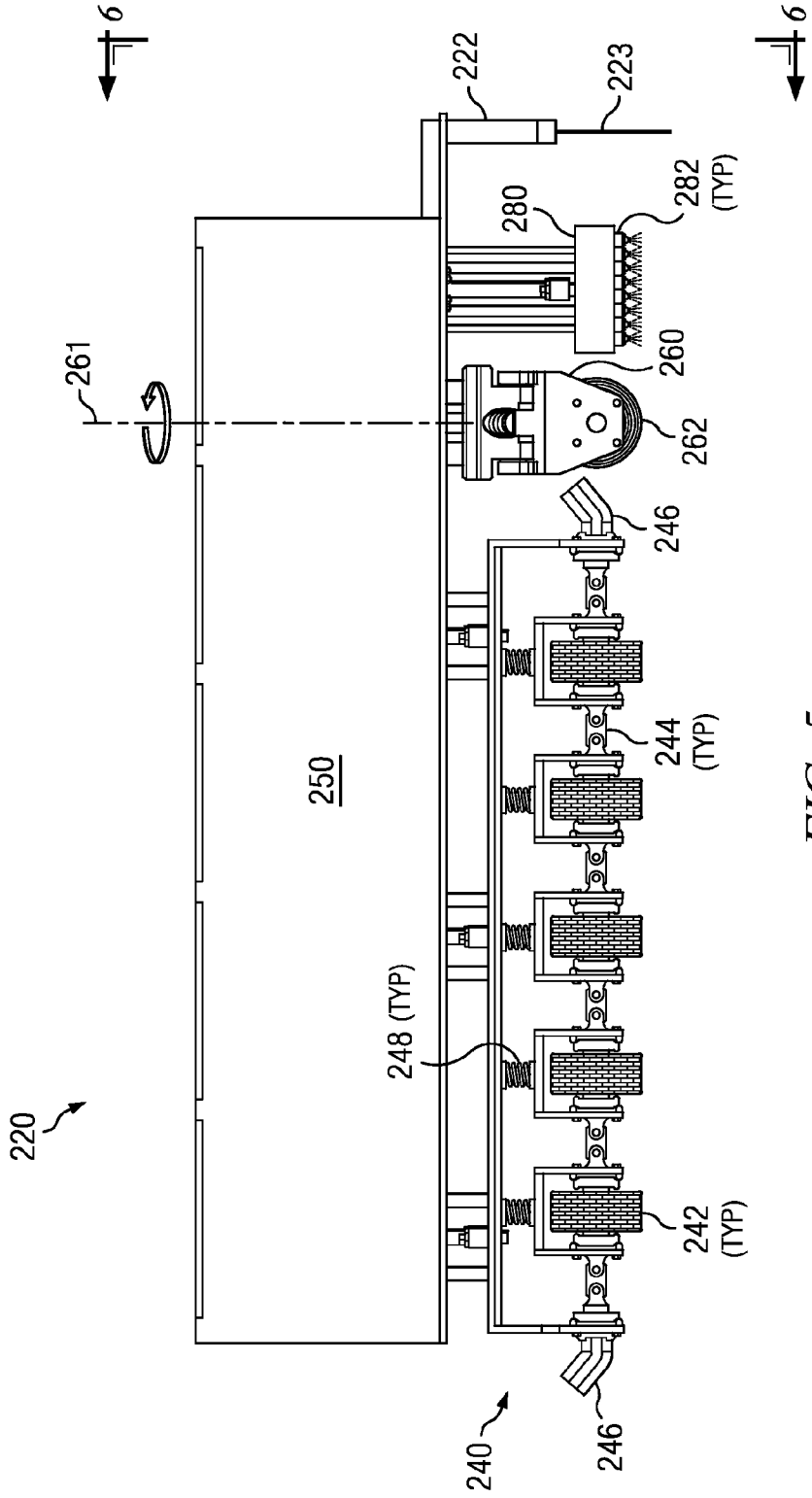

FIG. 5

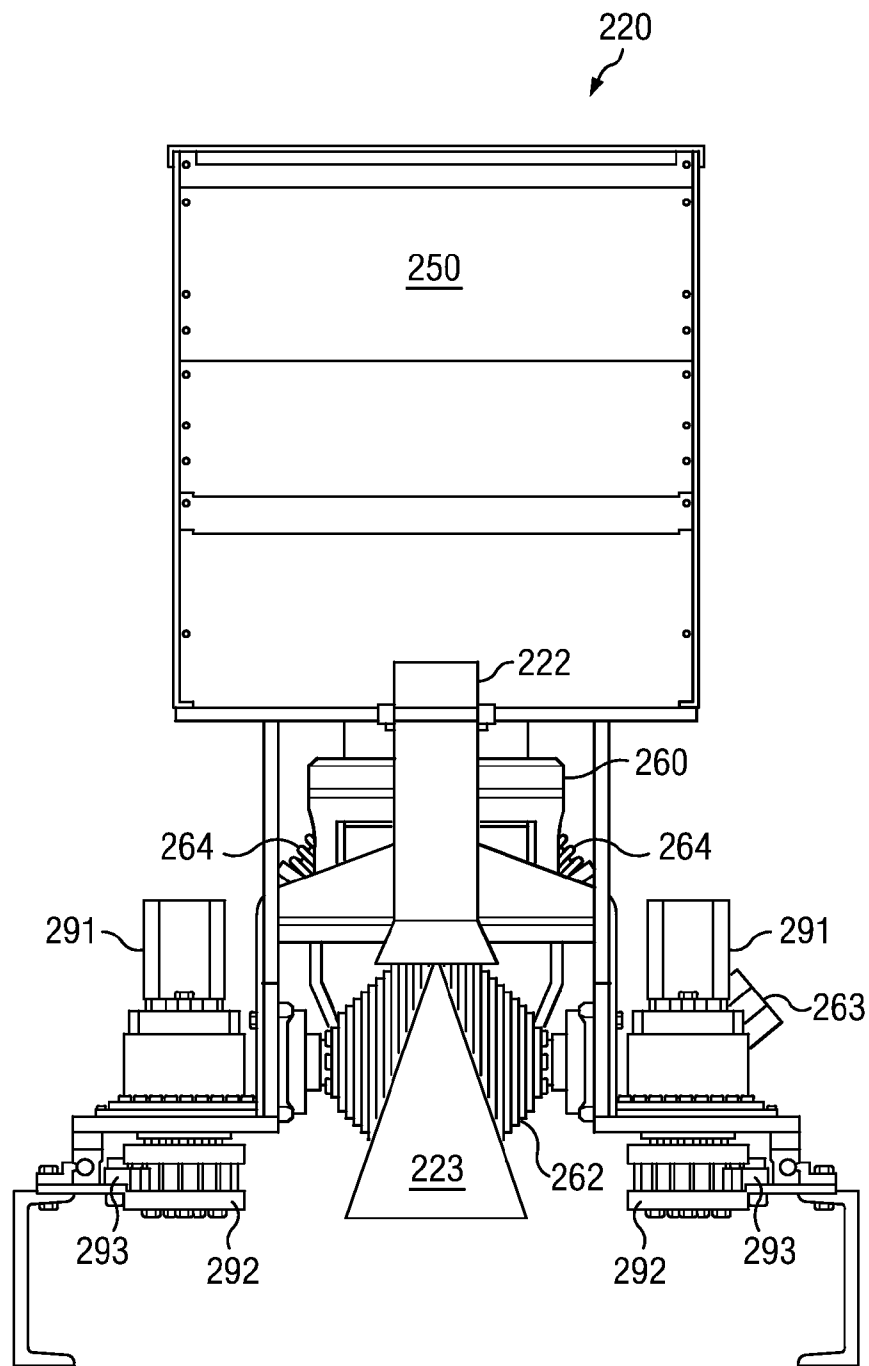

FIG. 6

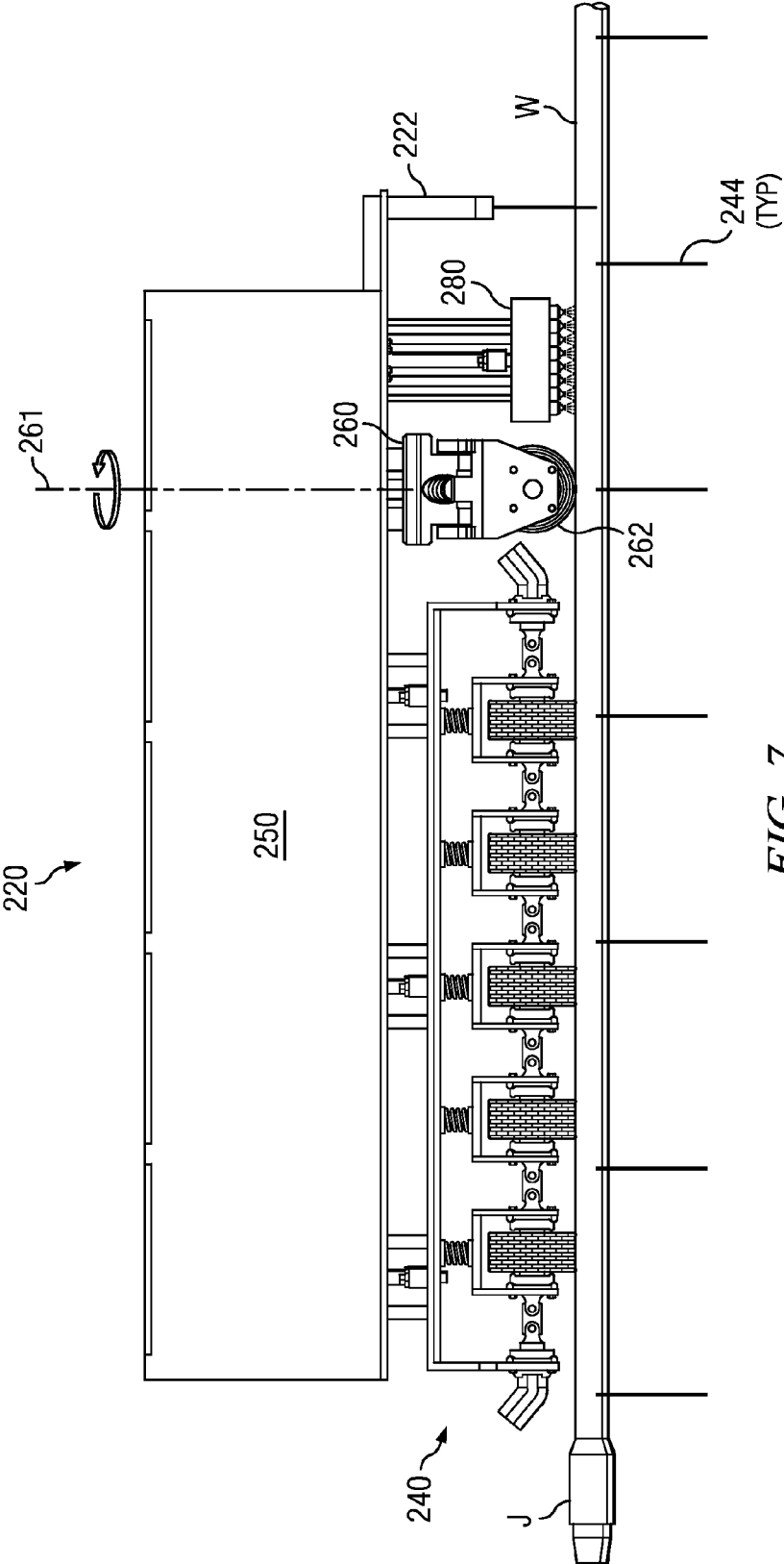

FIG. 7



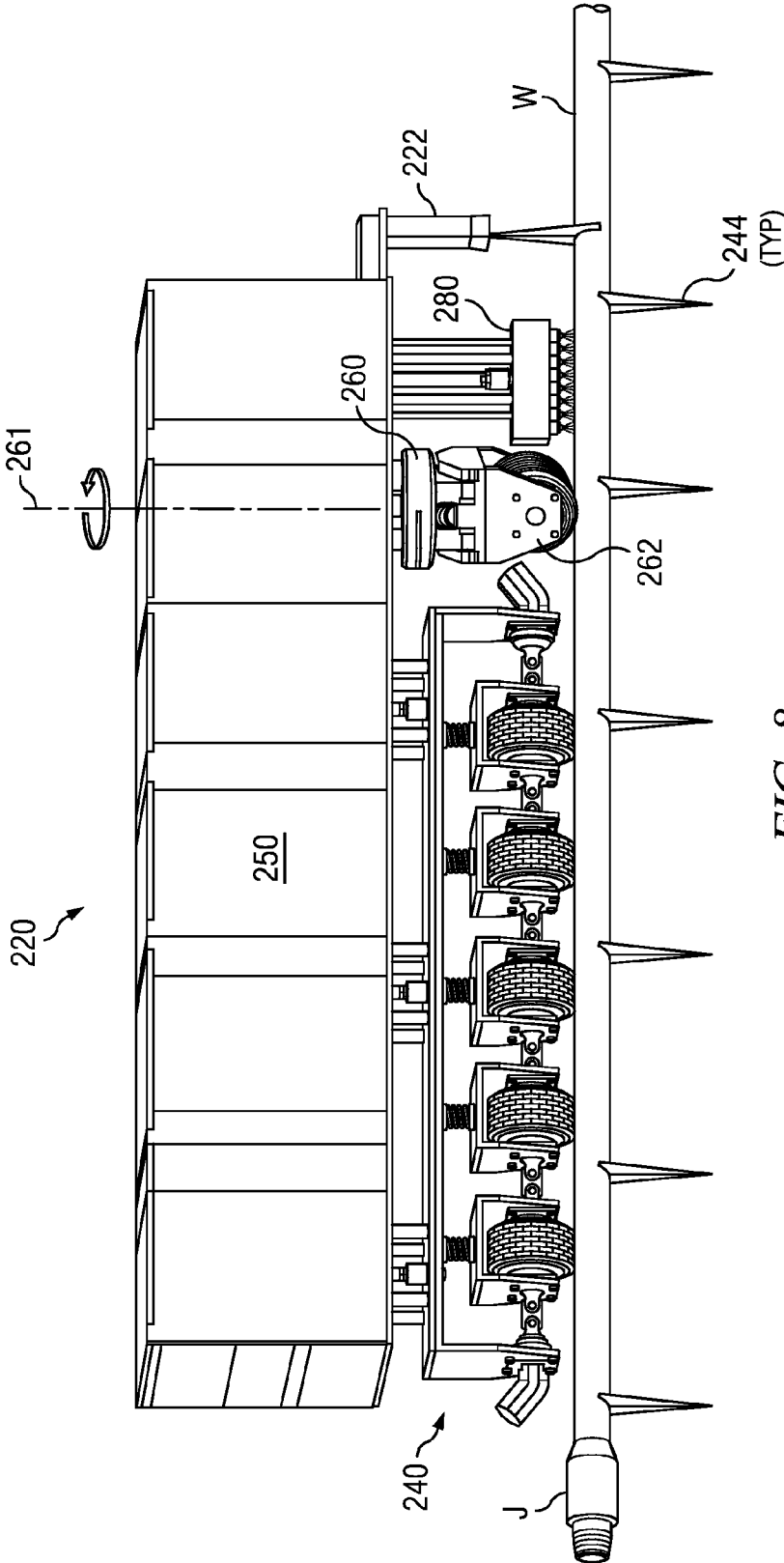

FIG. 8

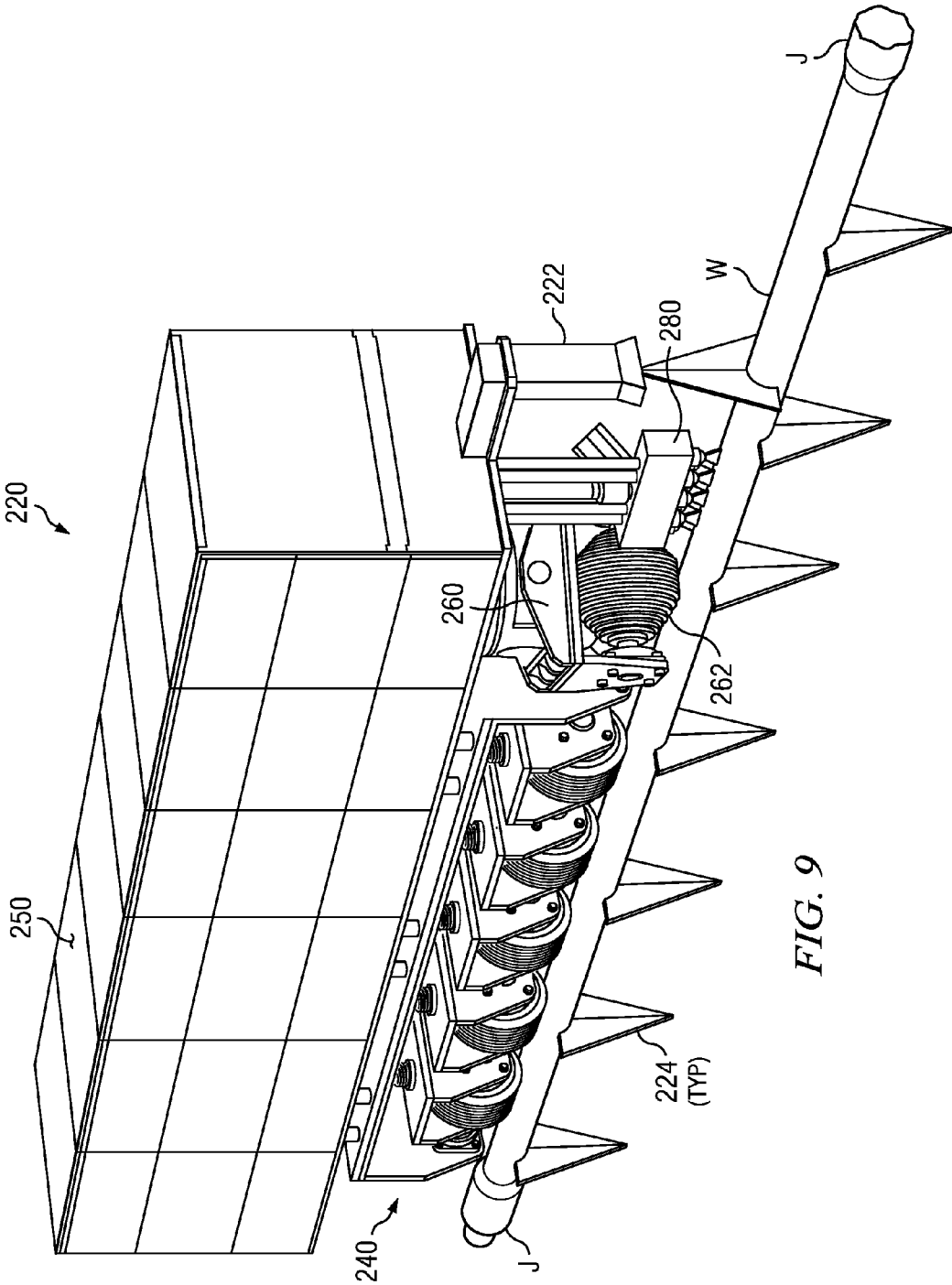

FIG. 9

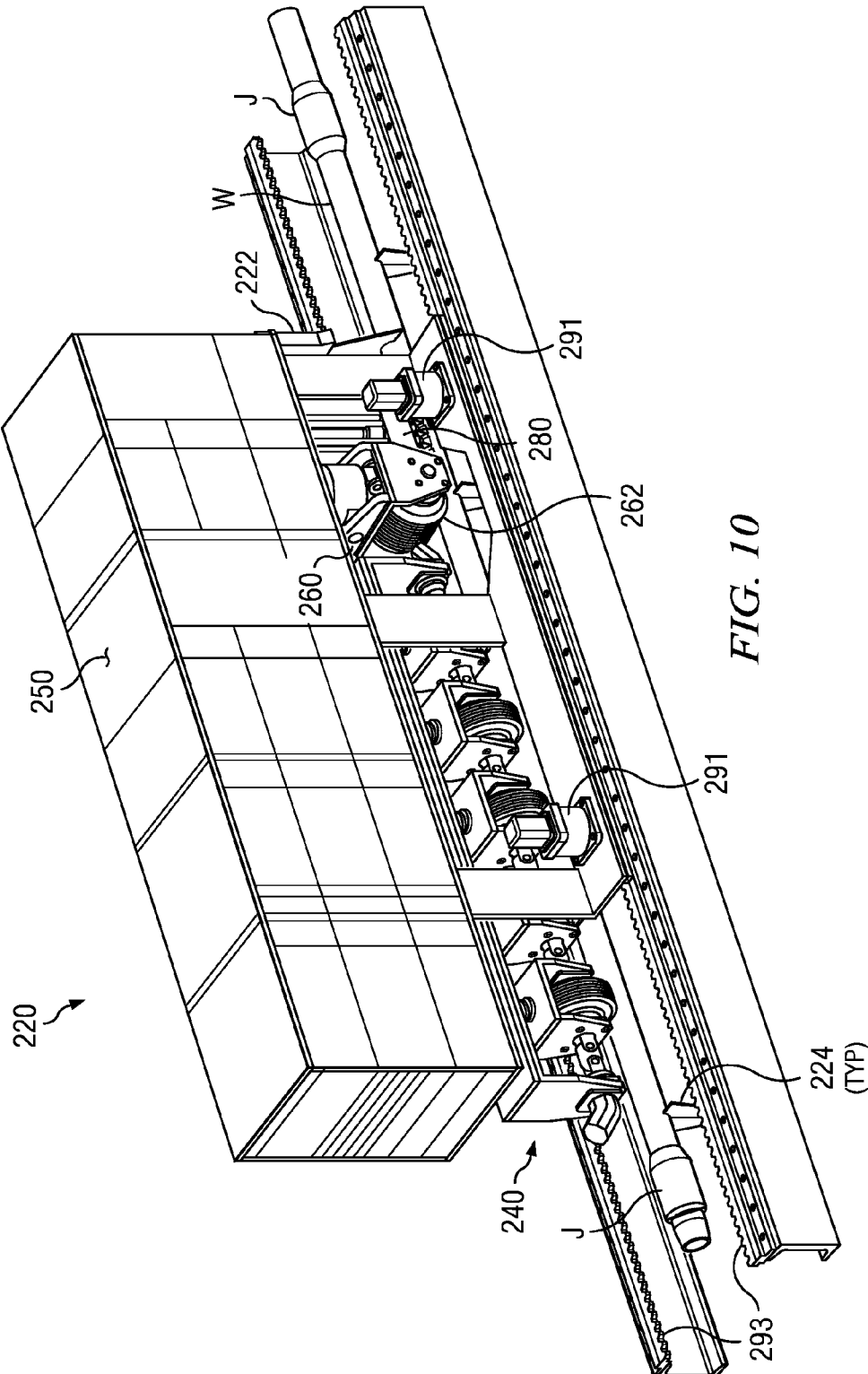

FIG. 10

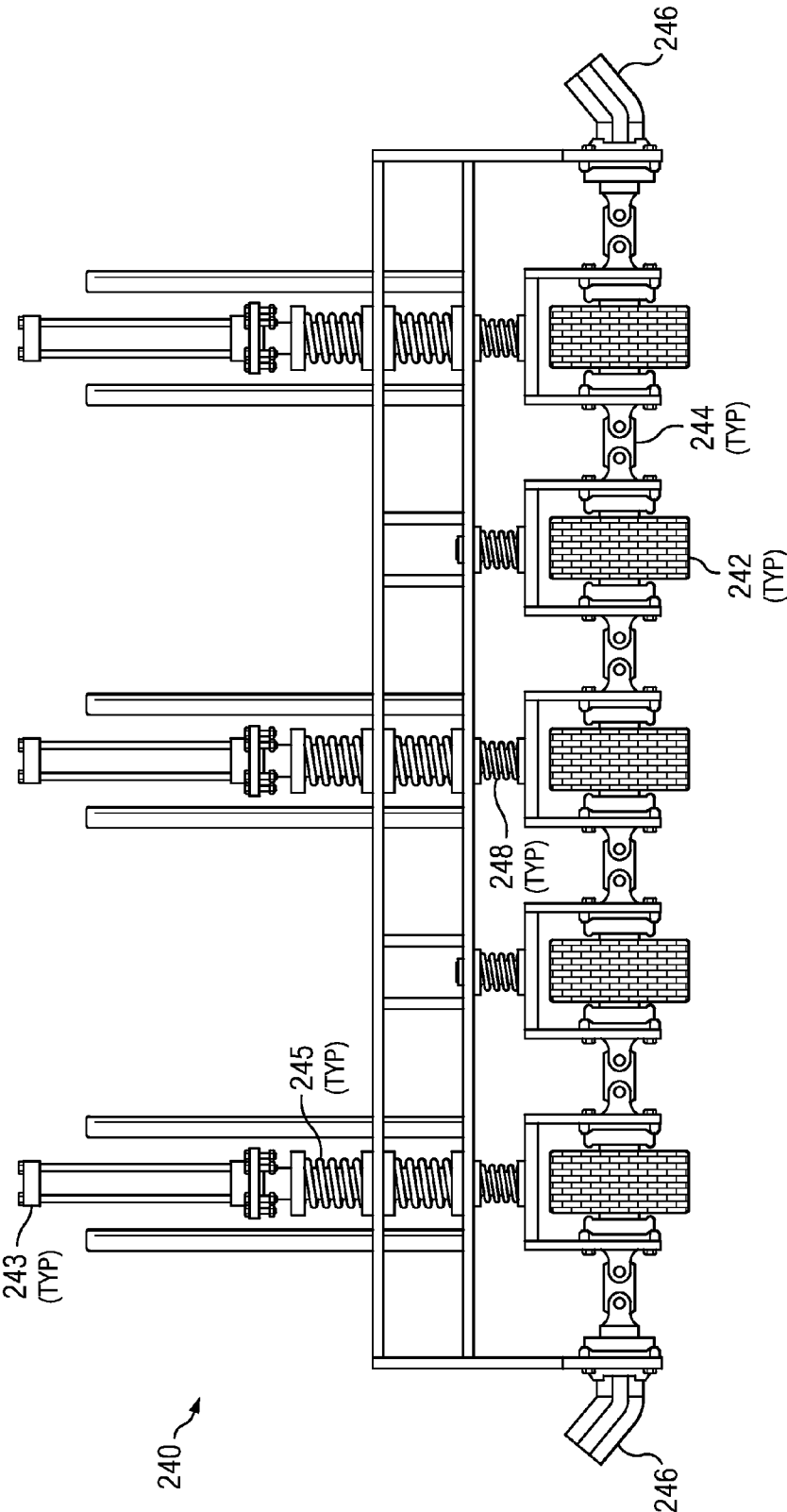

FIG. 11

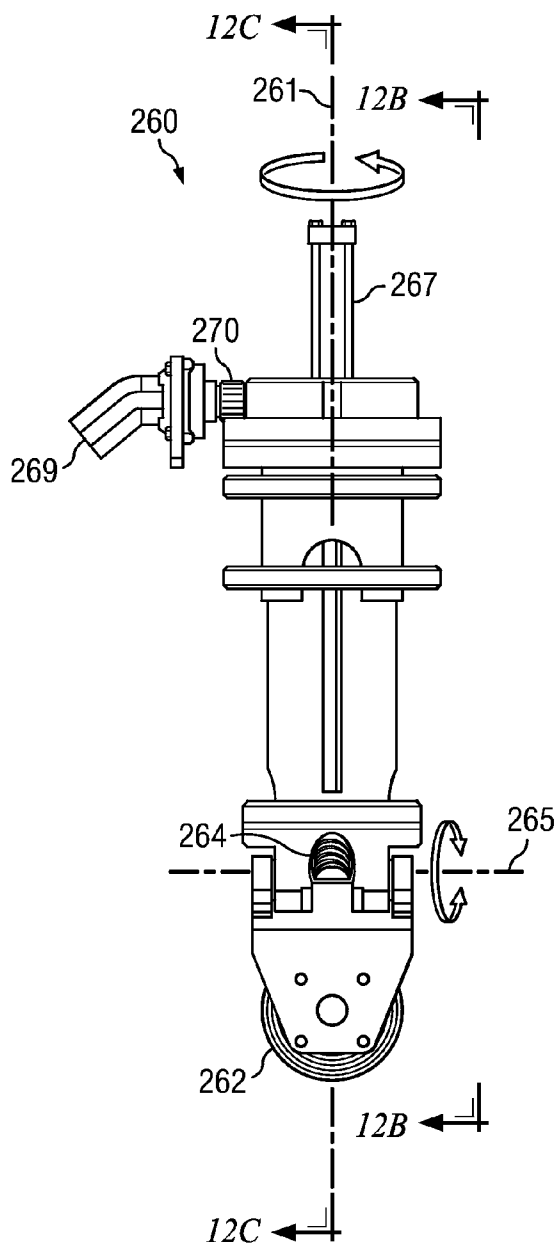

FIG. 12A

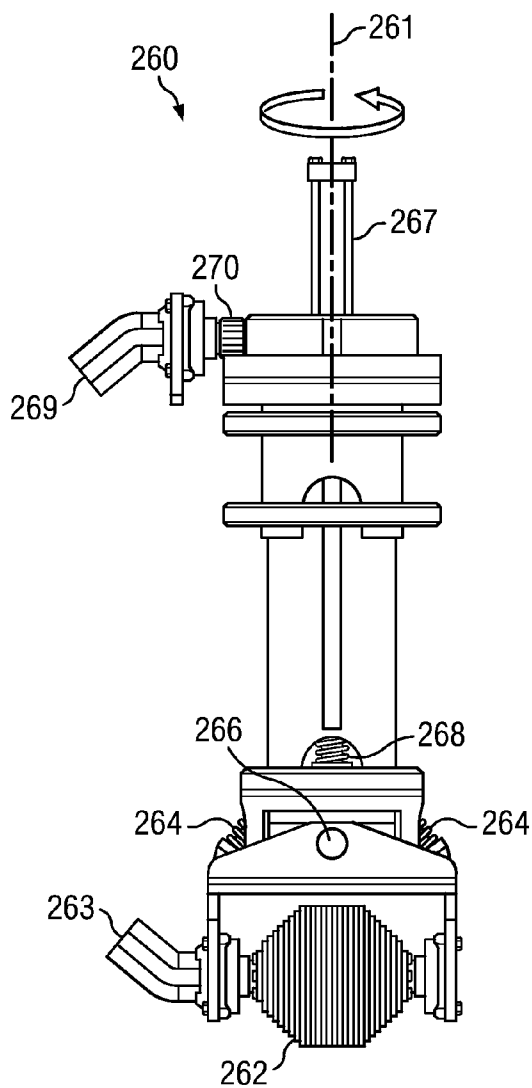

FIG. 12B

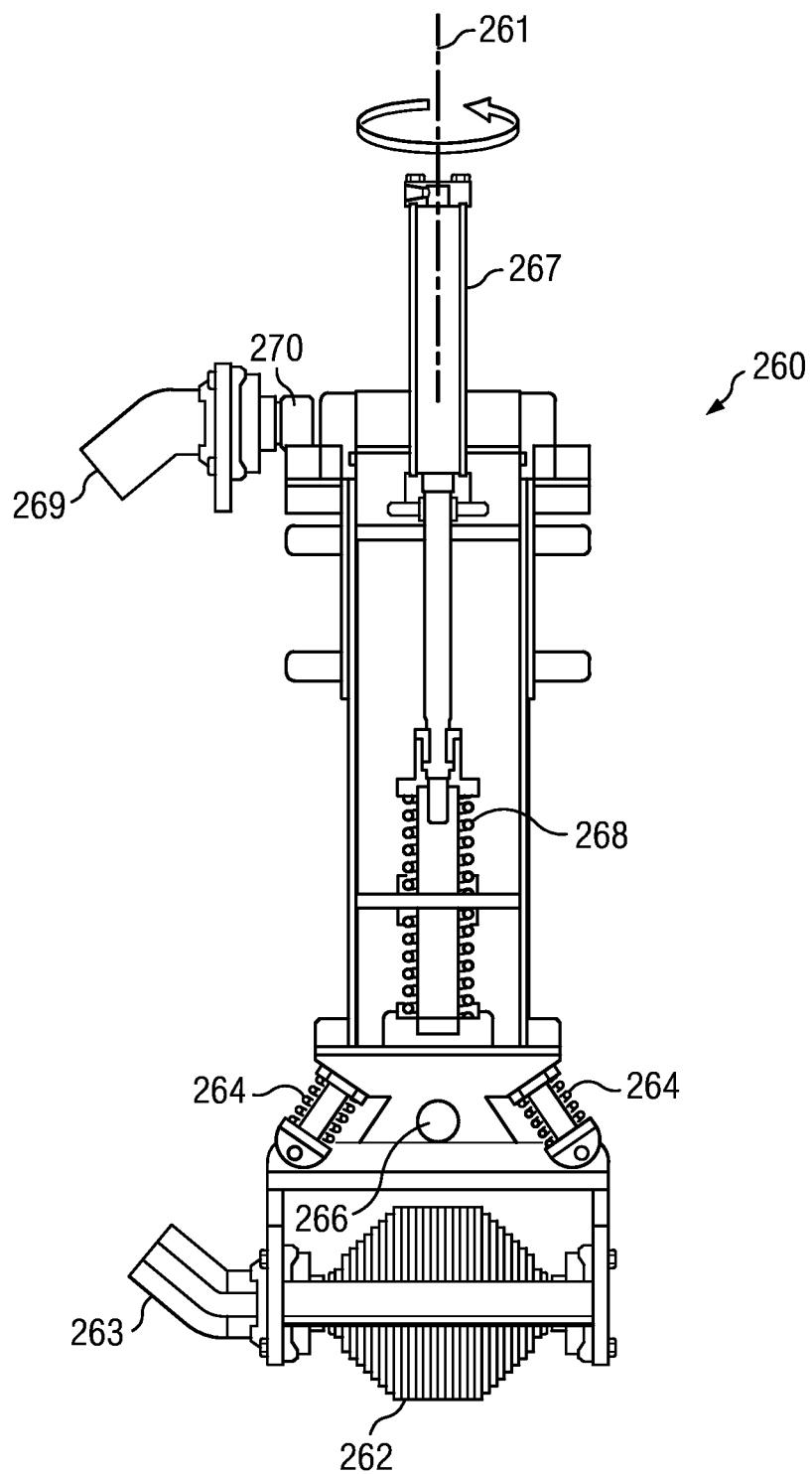
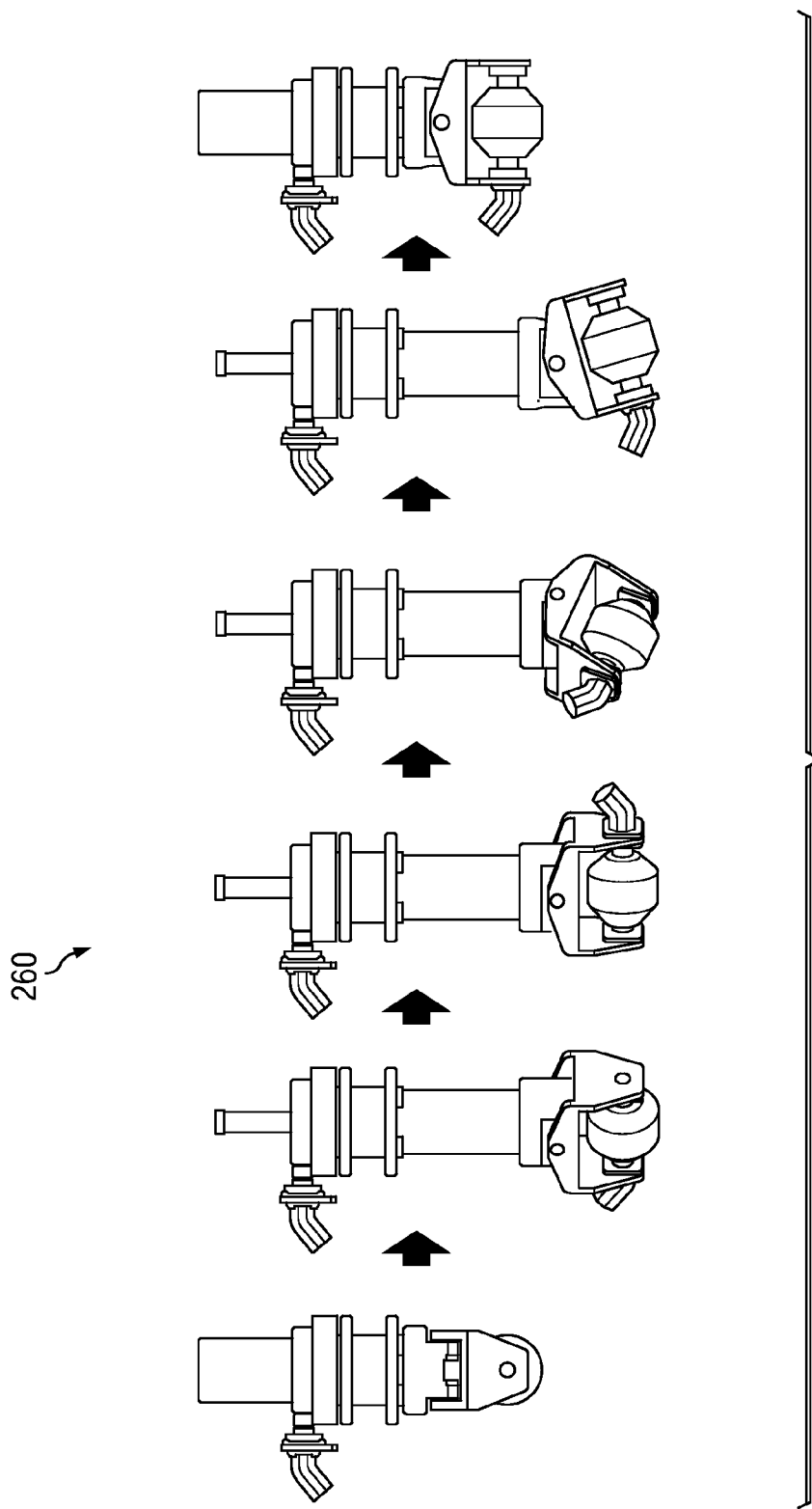

FIG. 12C



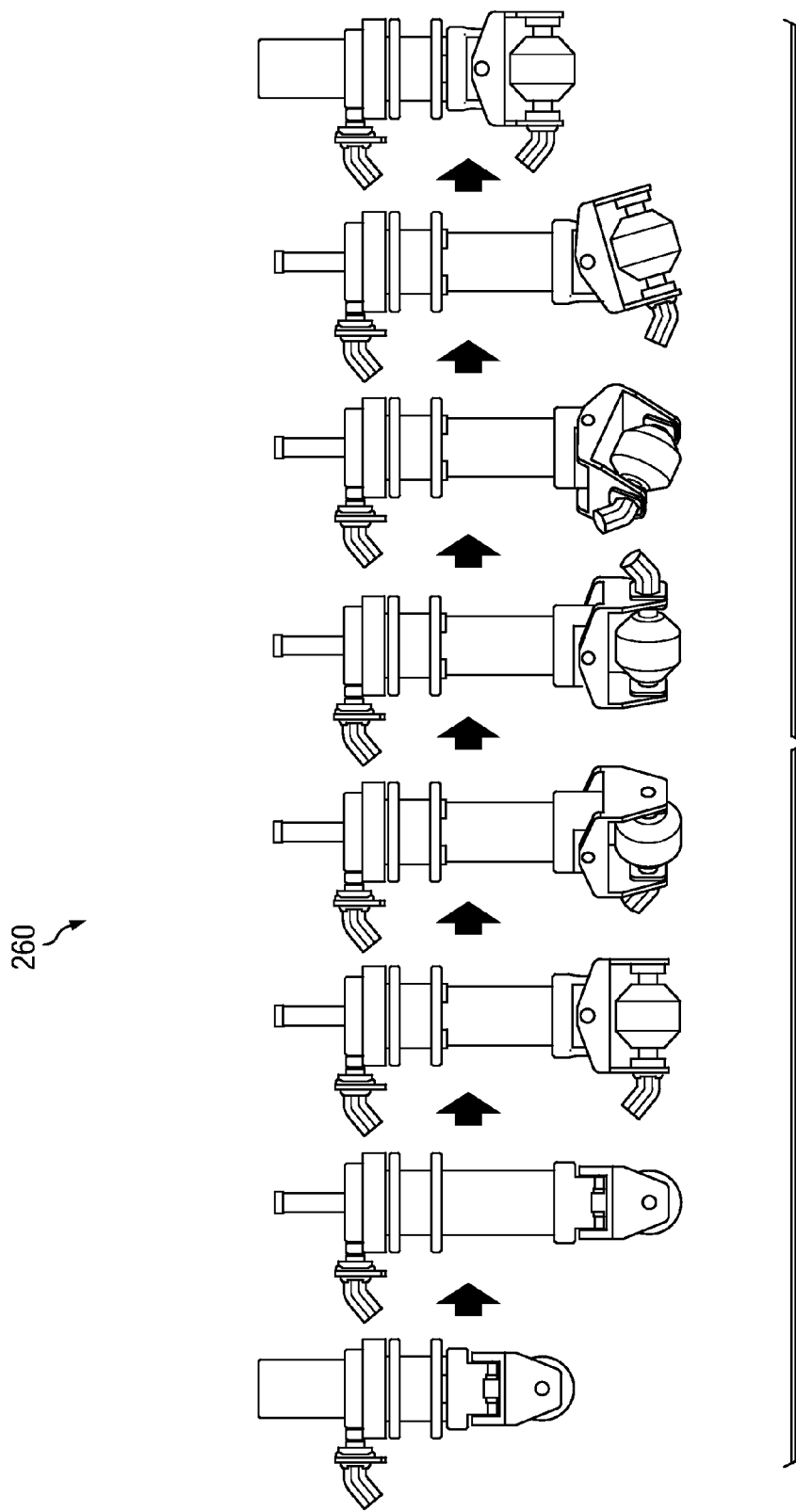

FIG. 12E



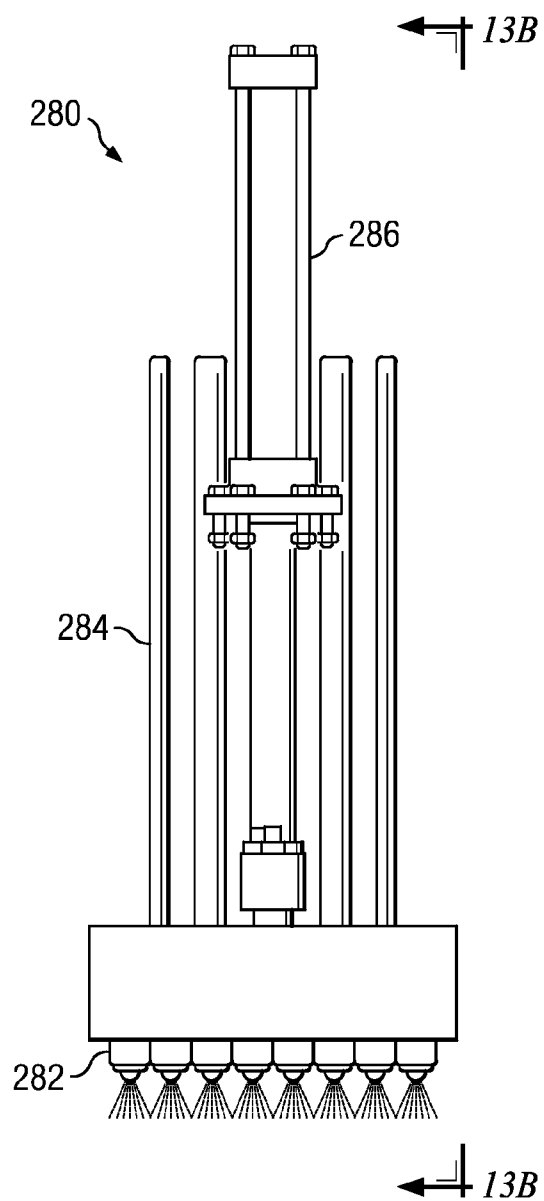

FIG. 13A

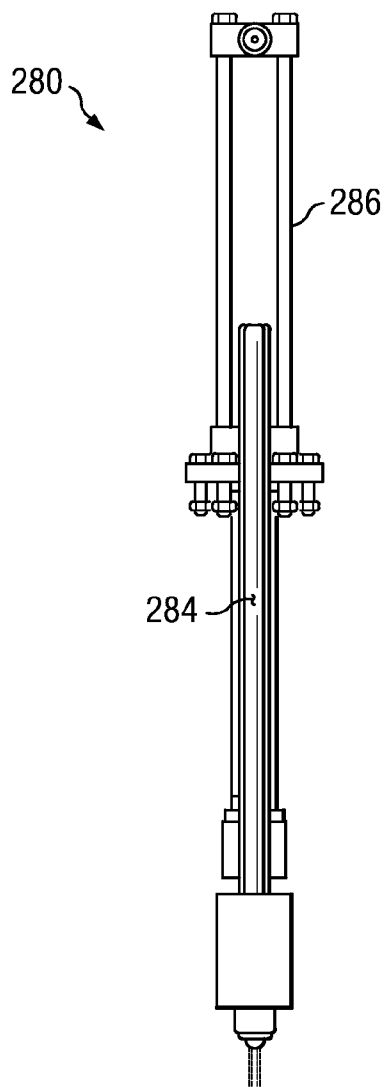

FIG. 13B

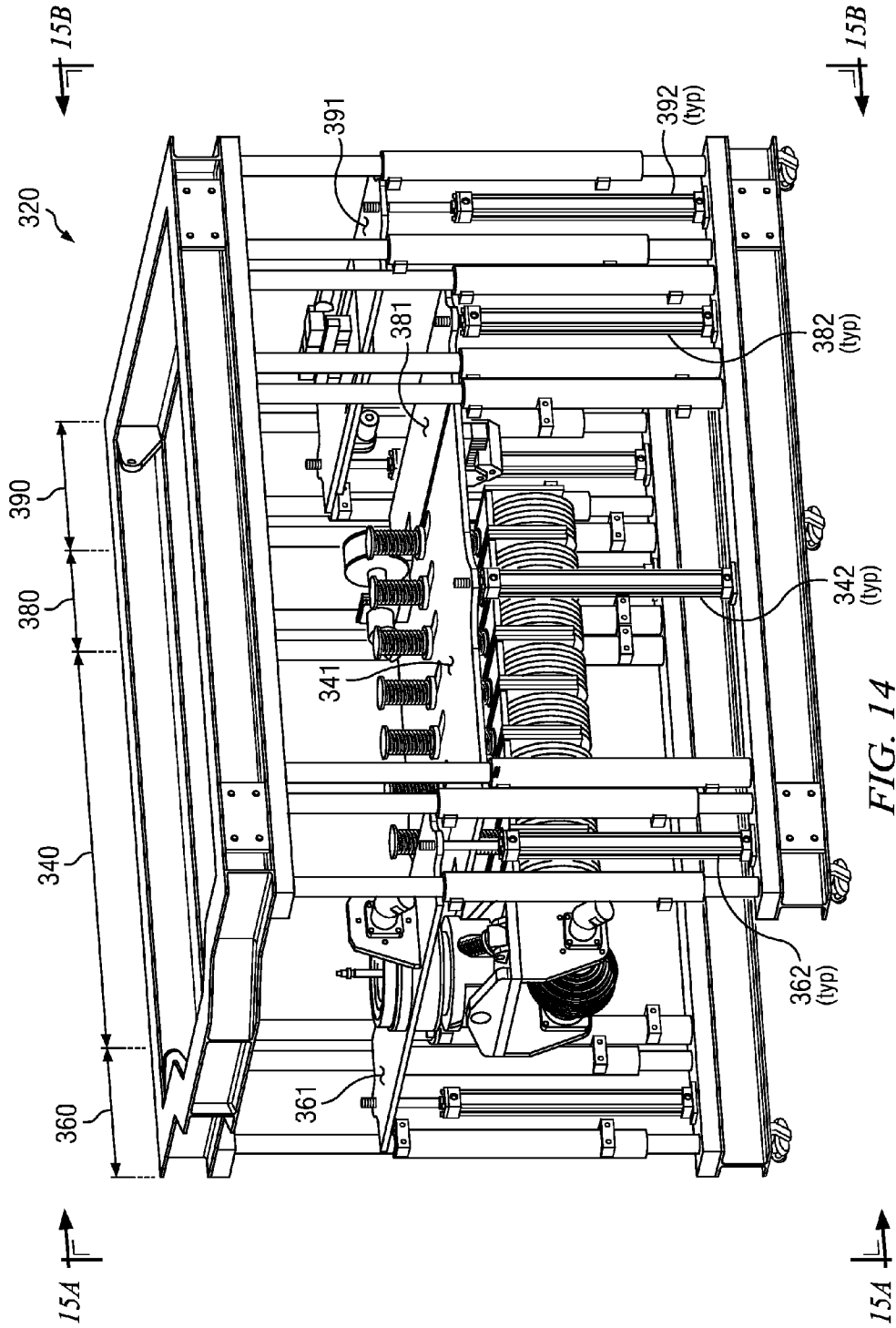

FIG. 14

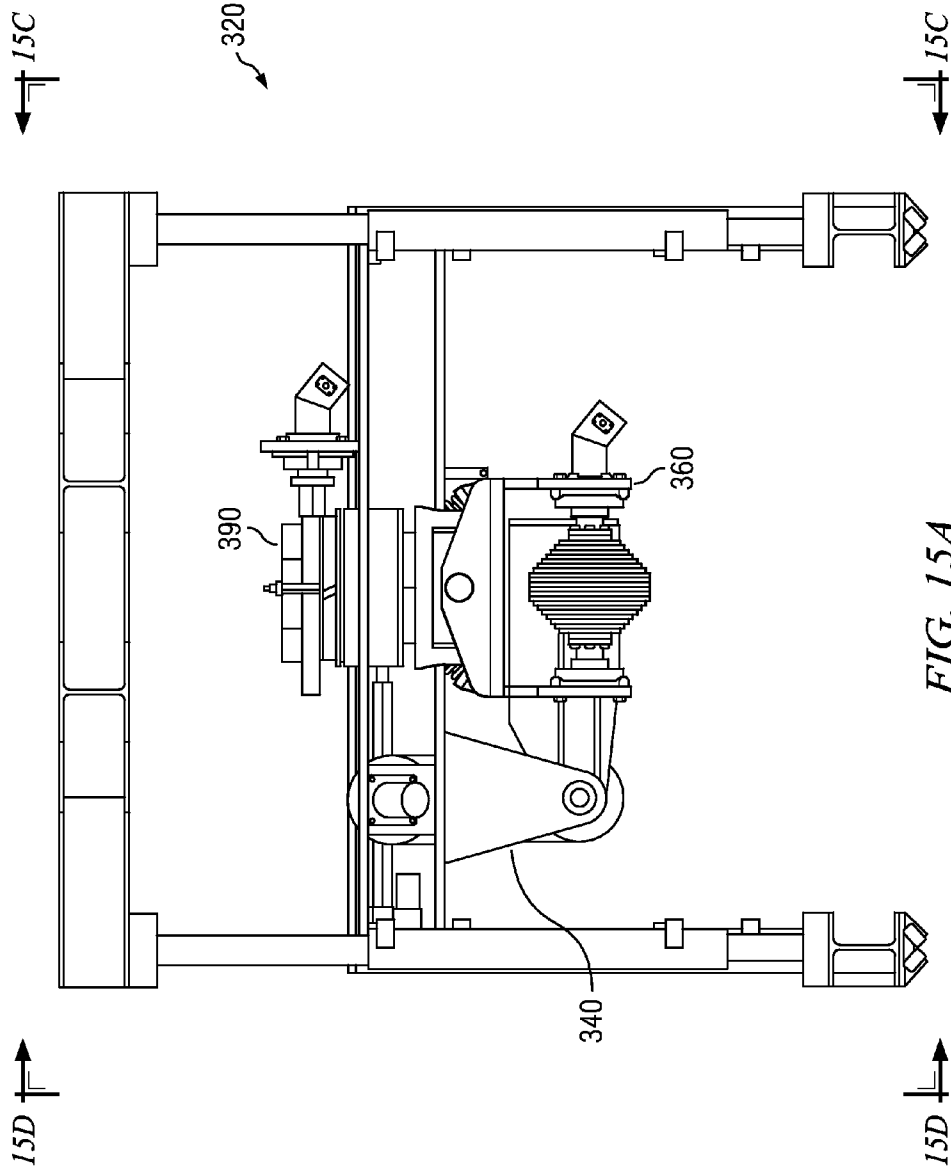

FIG. 15A

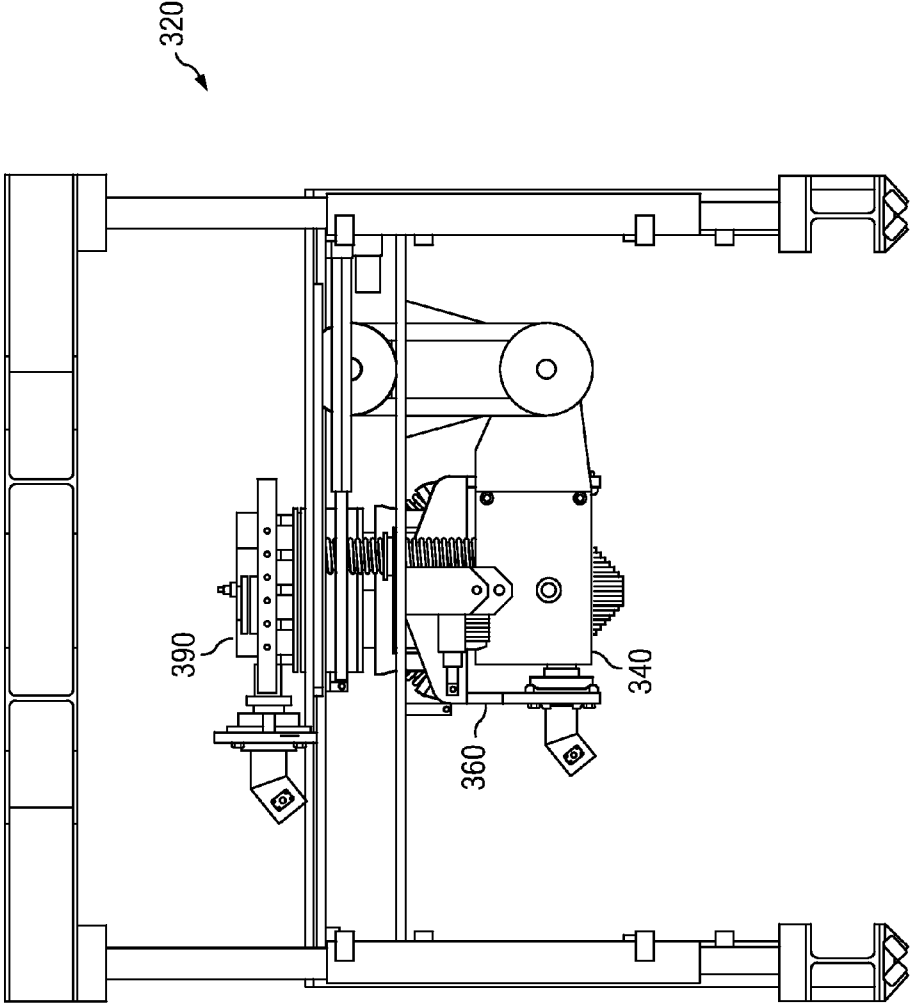

FIG. 15B

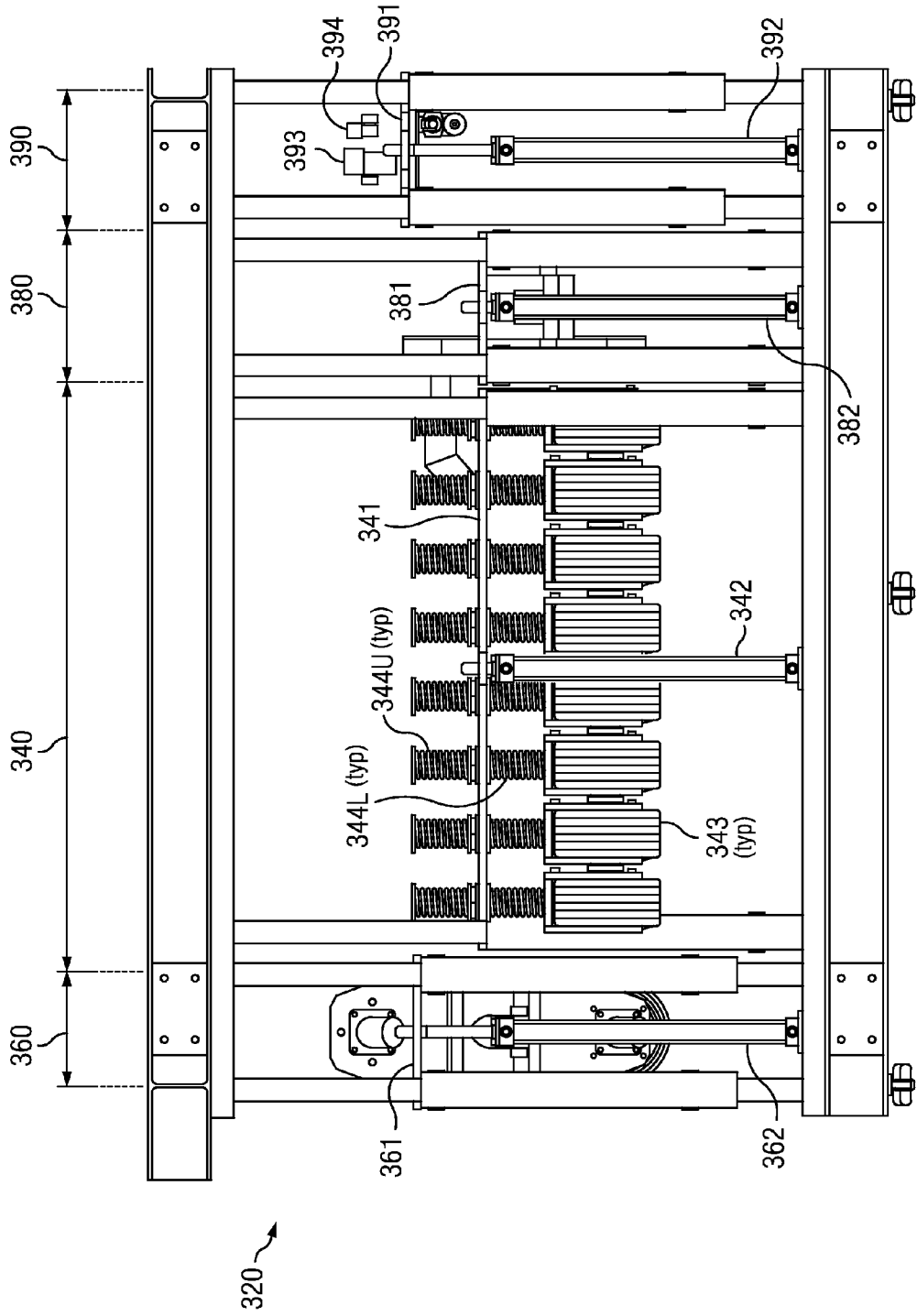

FIG. 15C

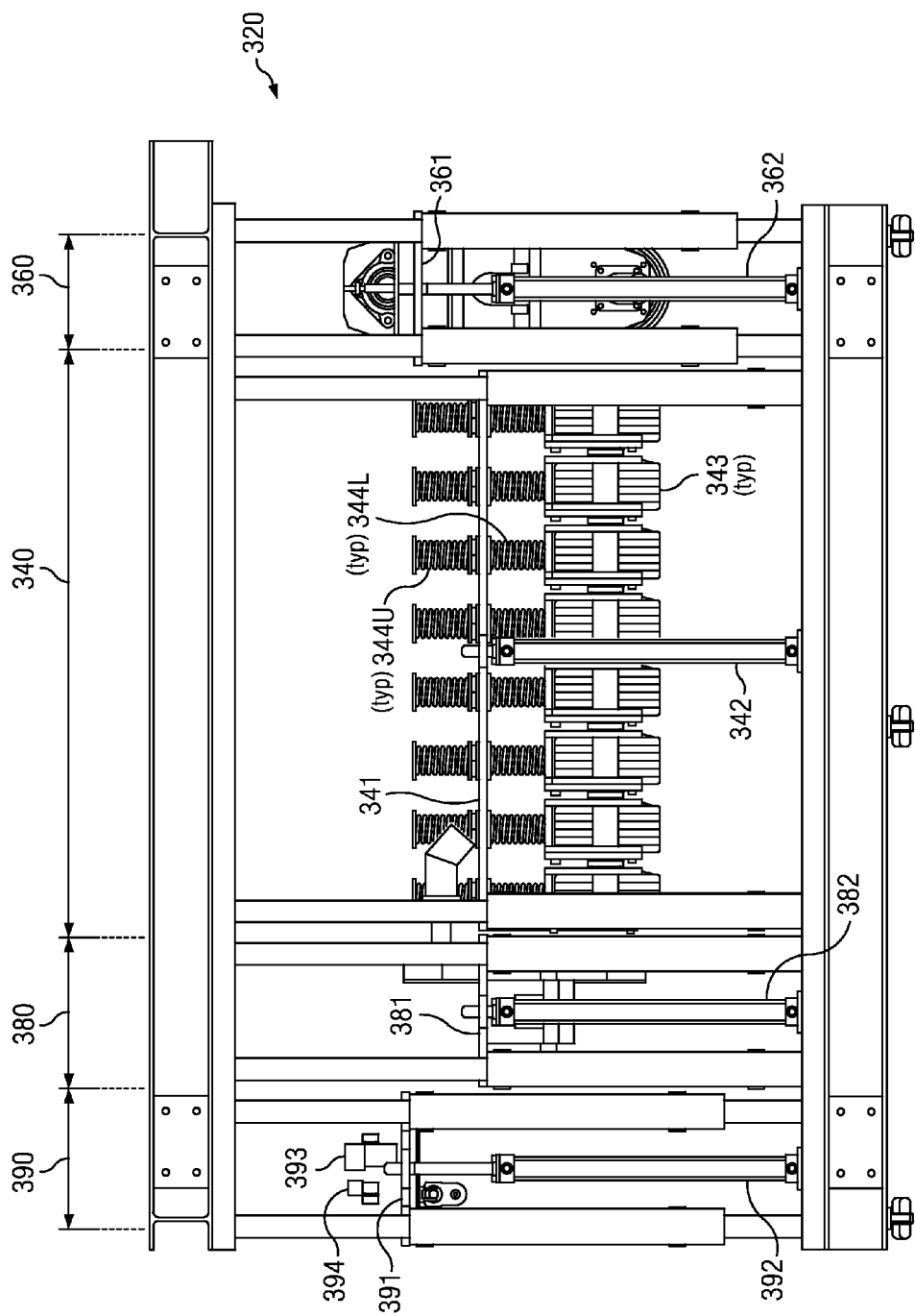

FIG. 15D

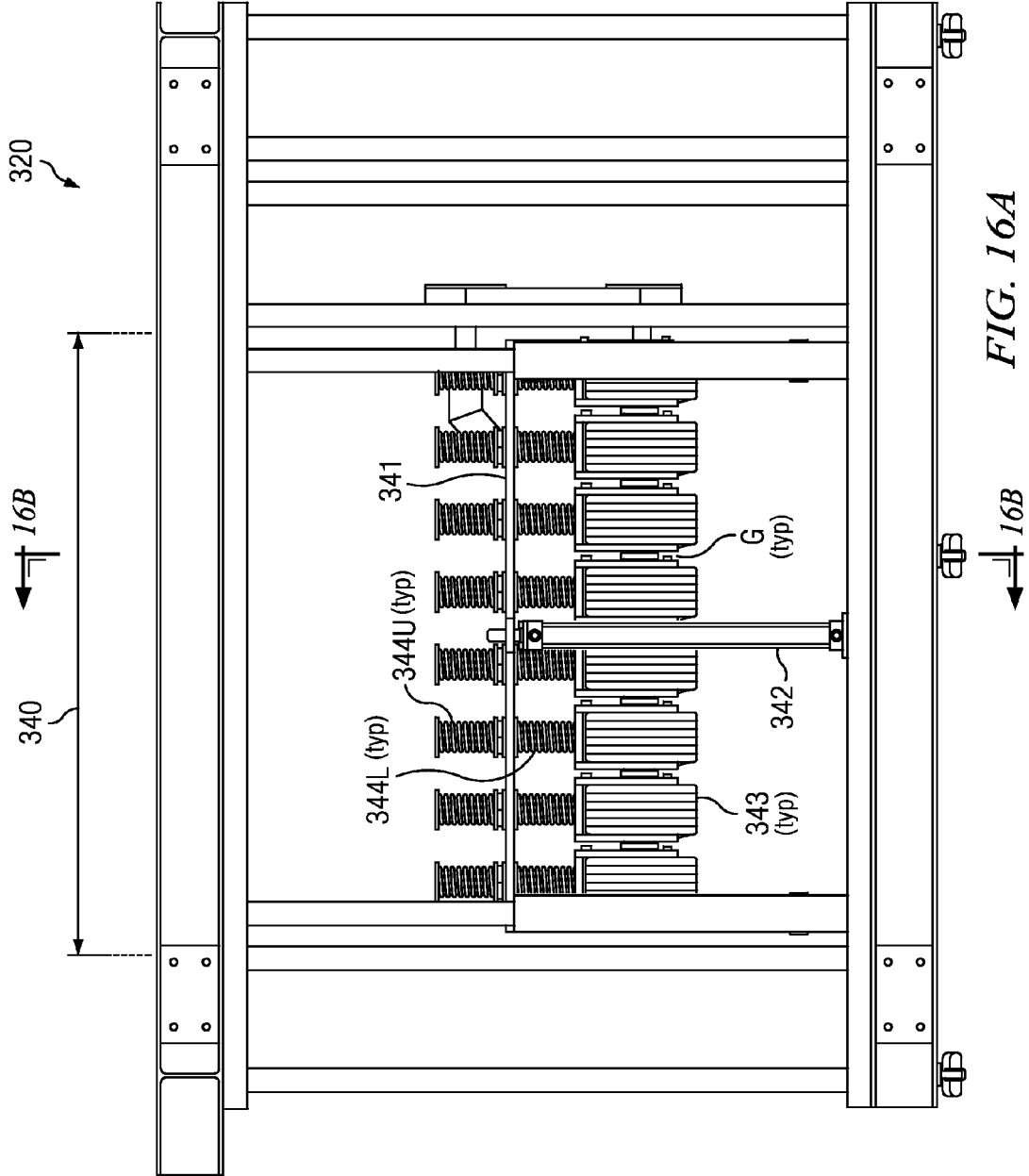

FIG. 16A

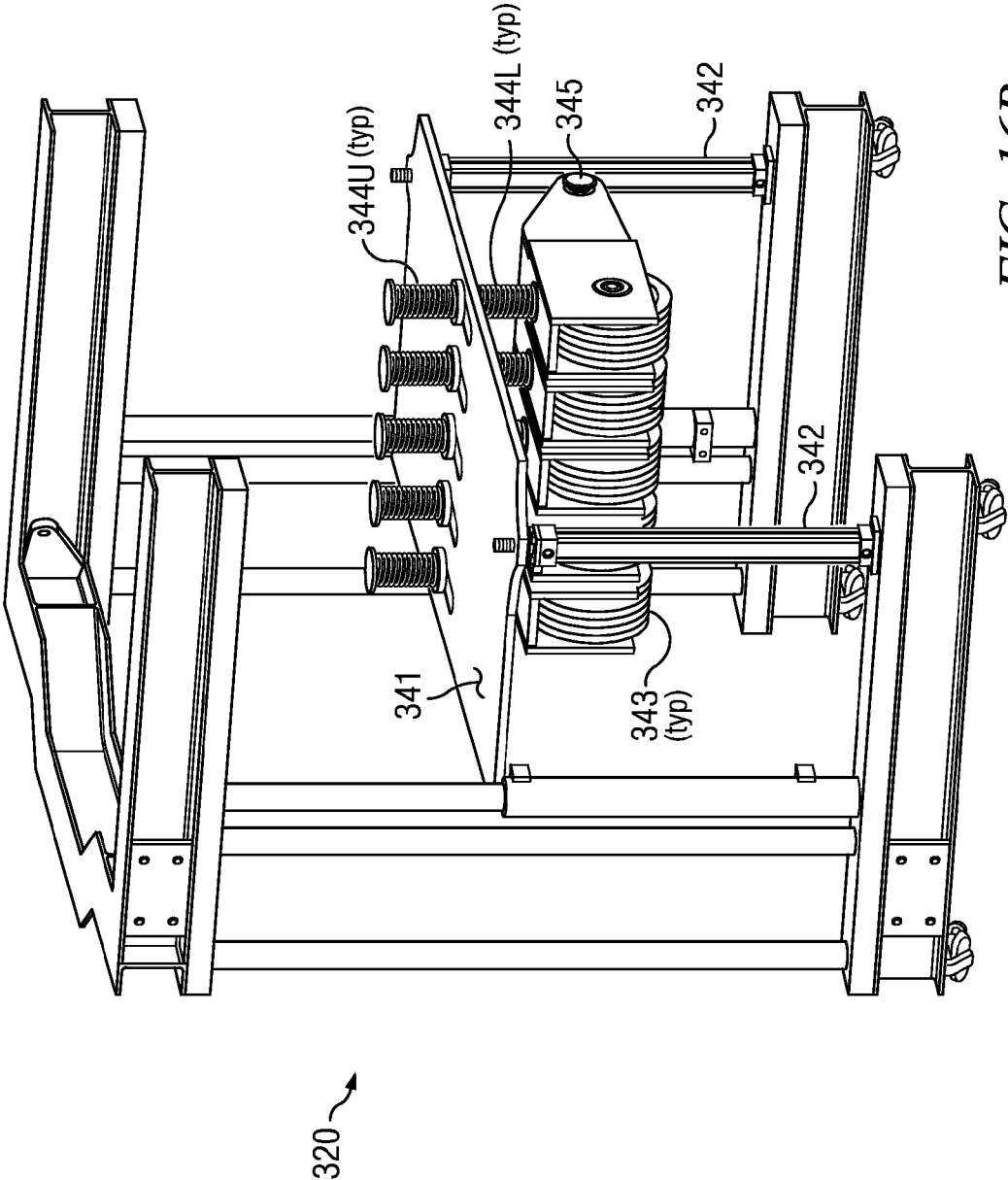

FIG. 16B



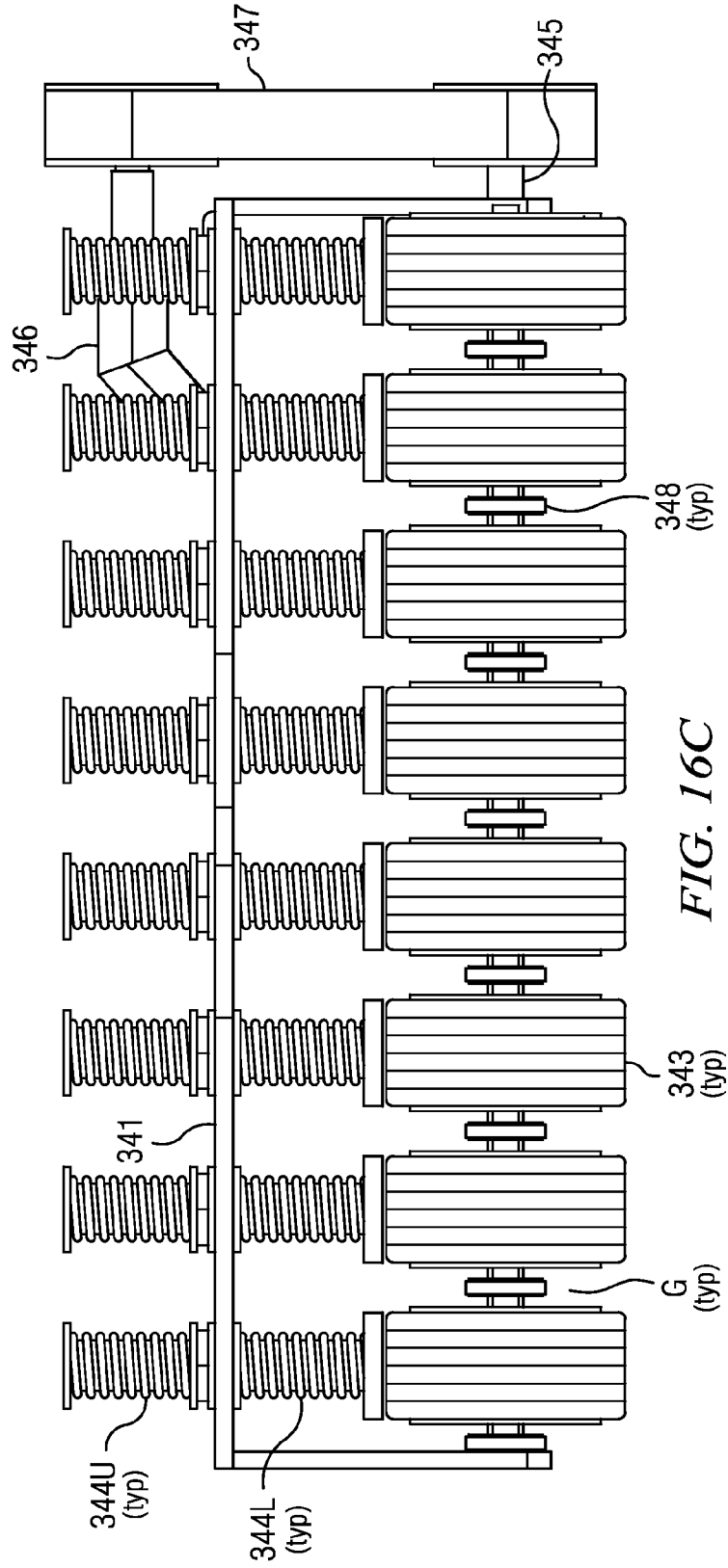

FIG. 16C

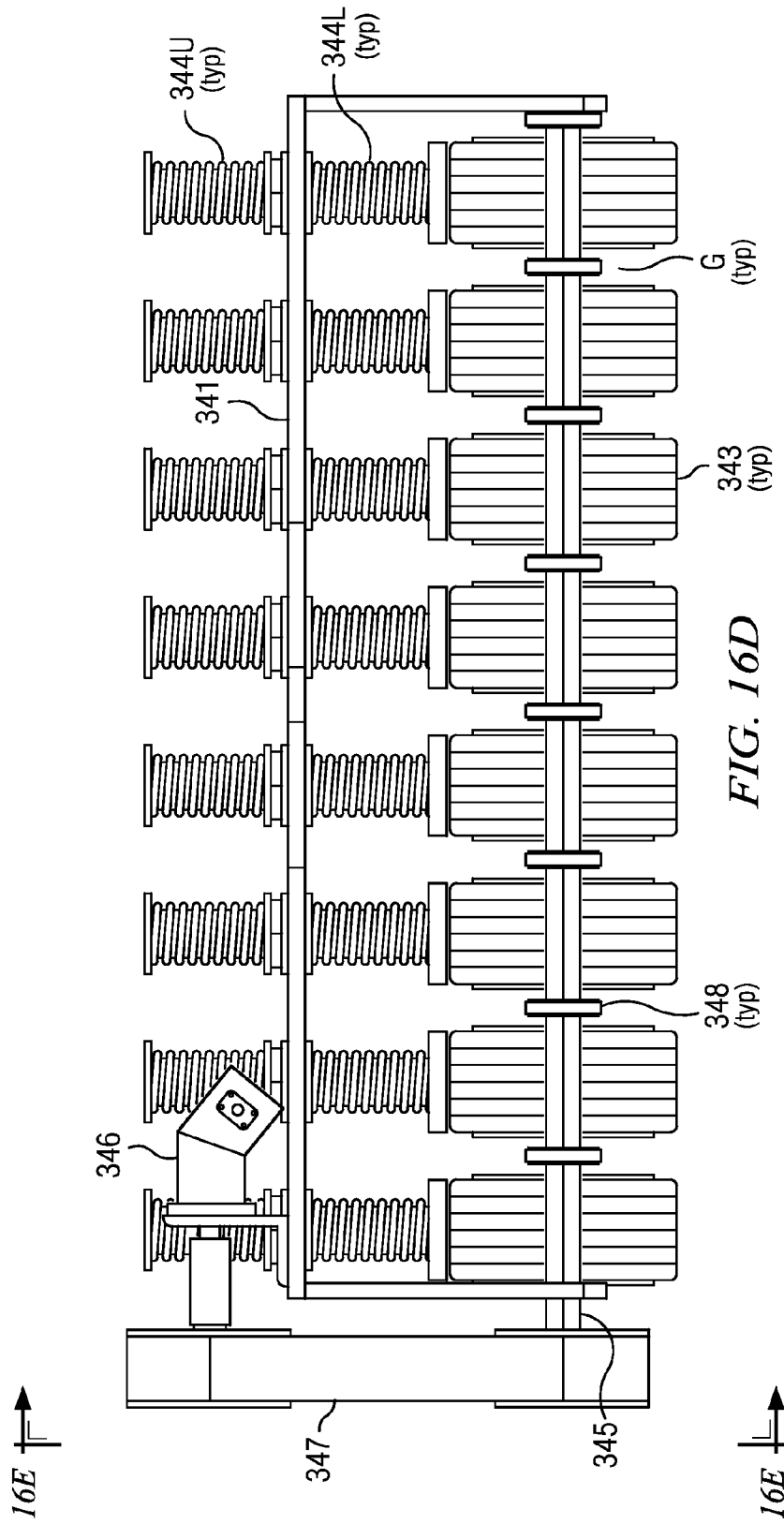

FIG. 16D

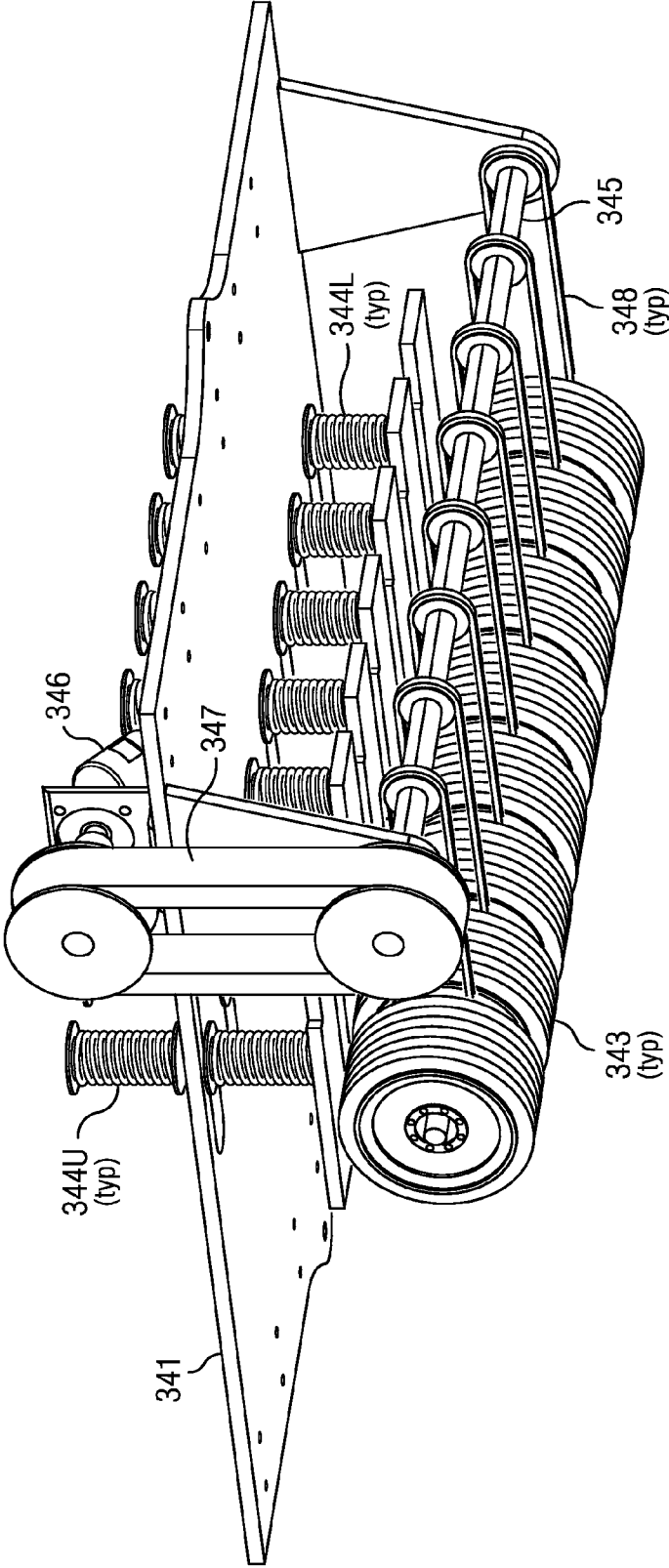

FIG. 16E

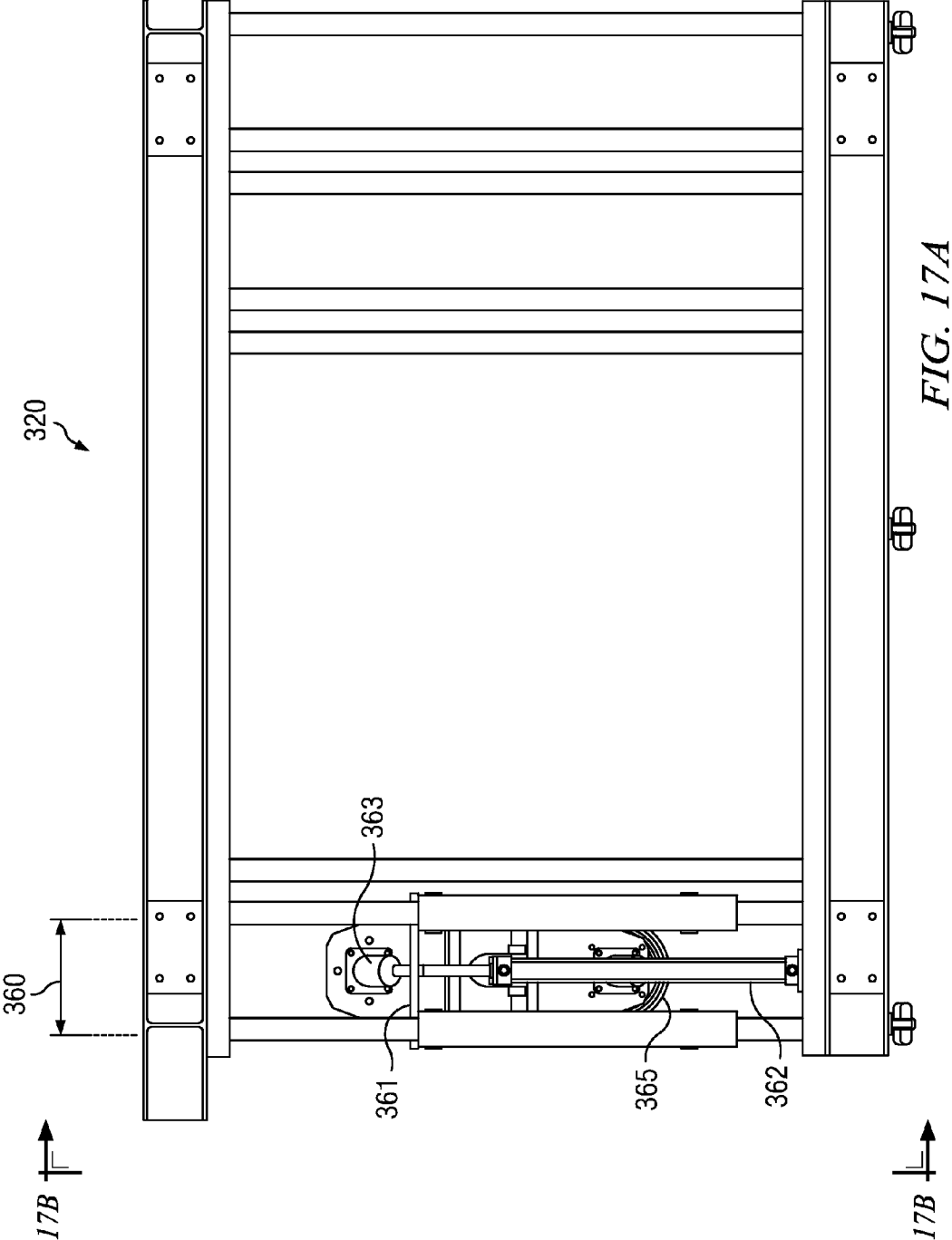

FIG. 17A

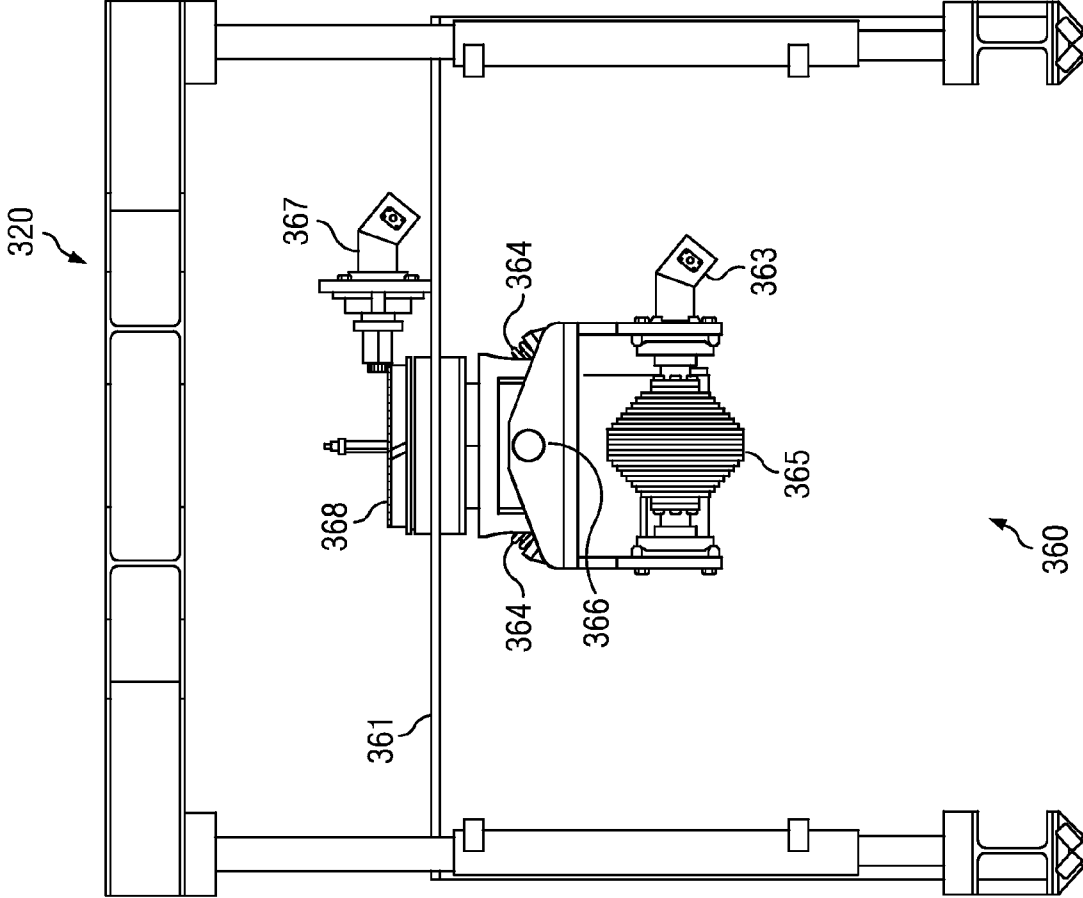

FIG. 17B

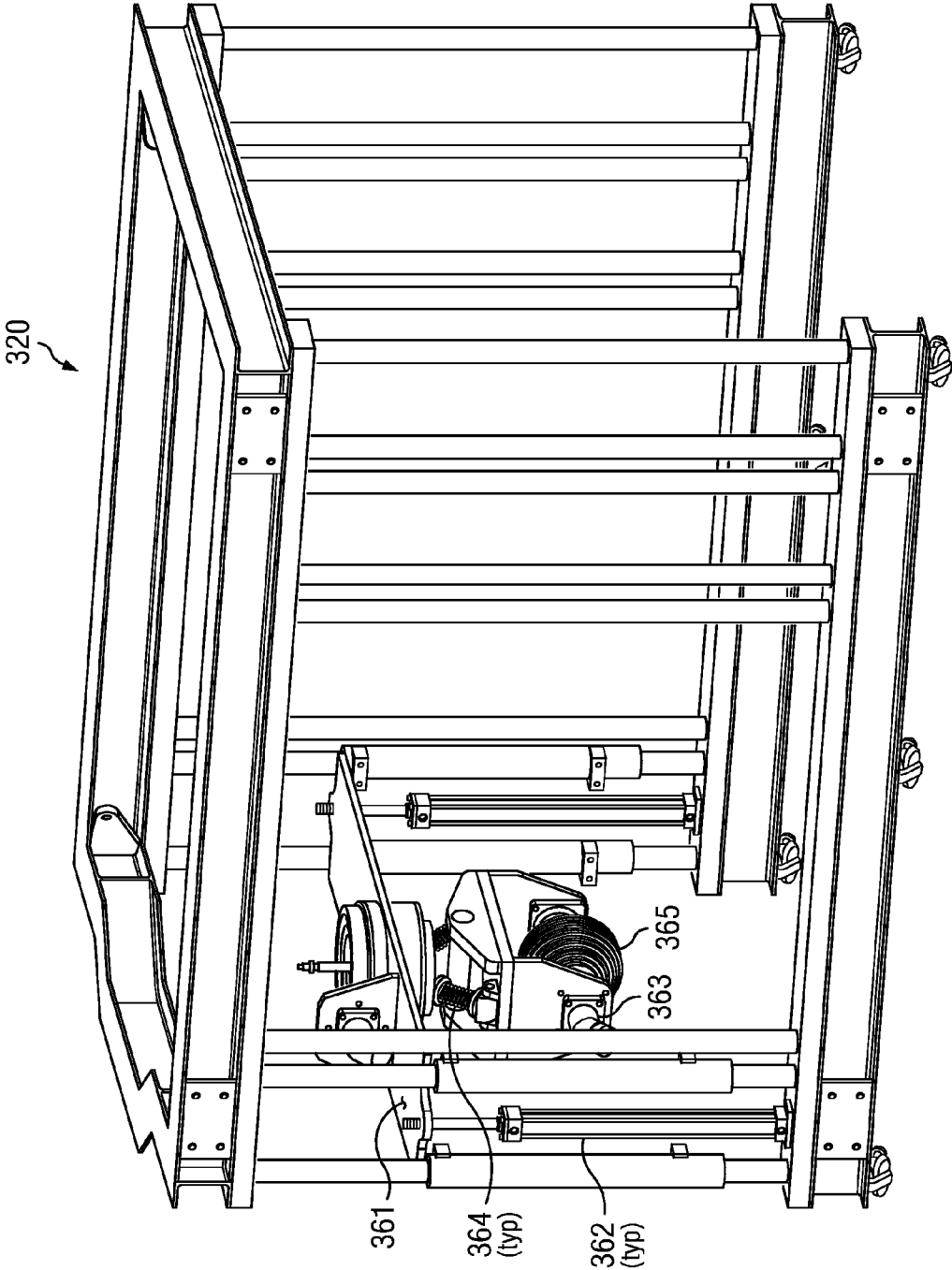

FIG. 17C

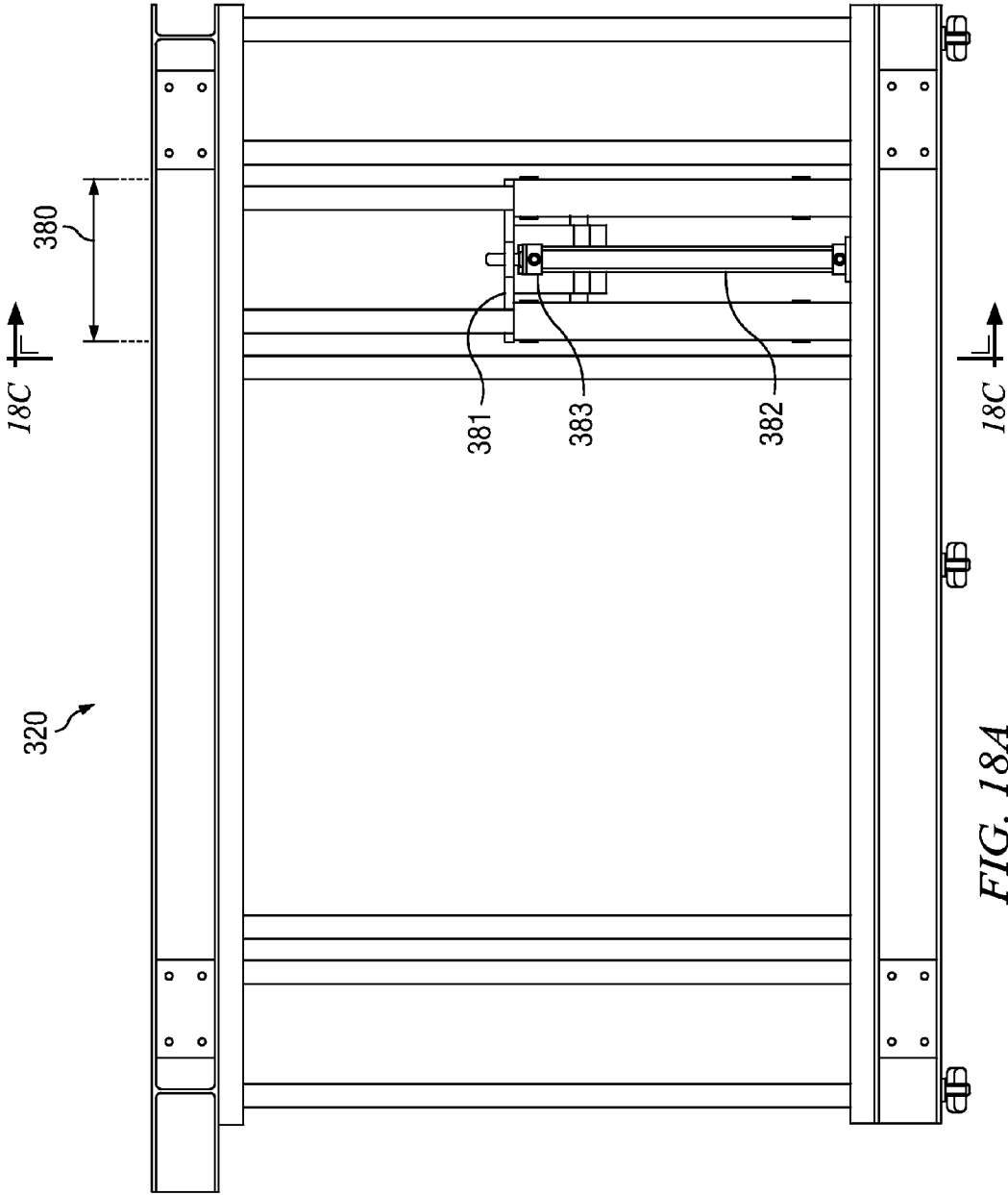

FIG. 18A

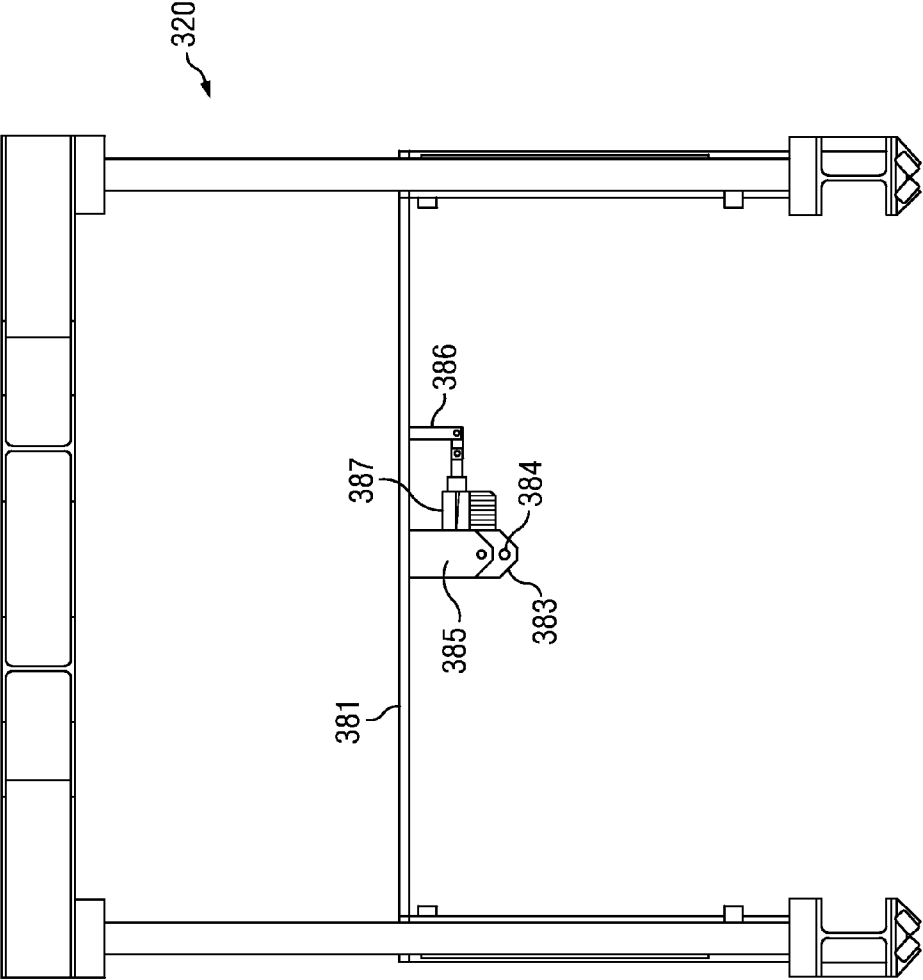

FIG. 18B



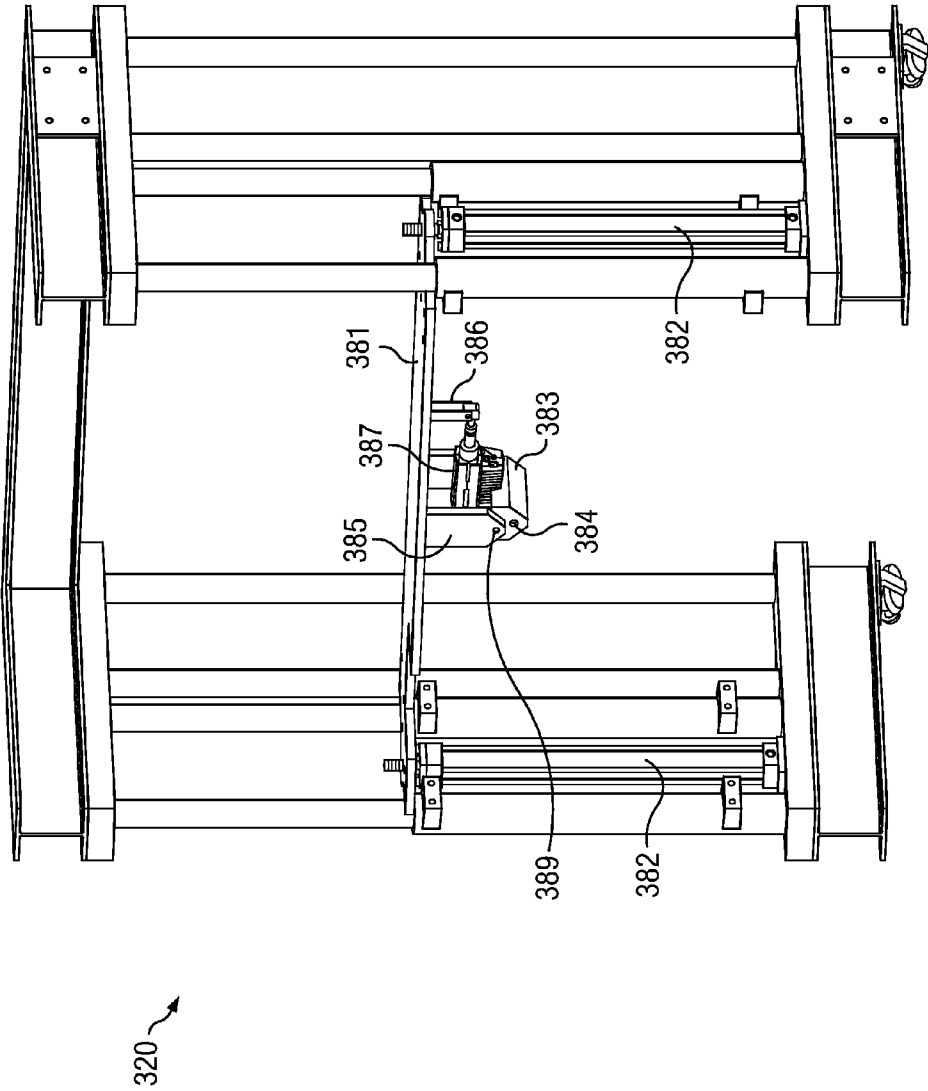
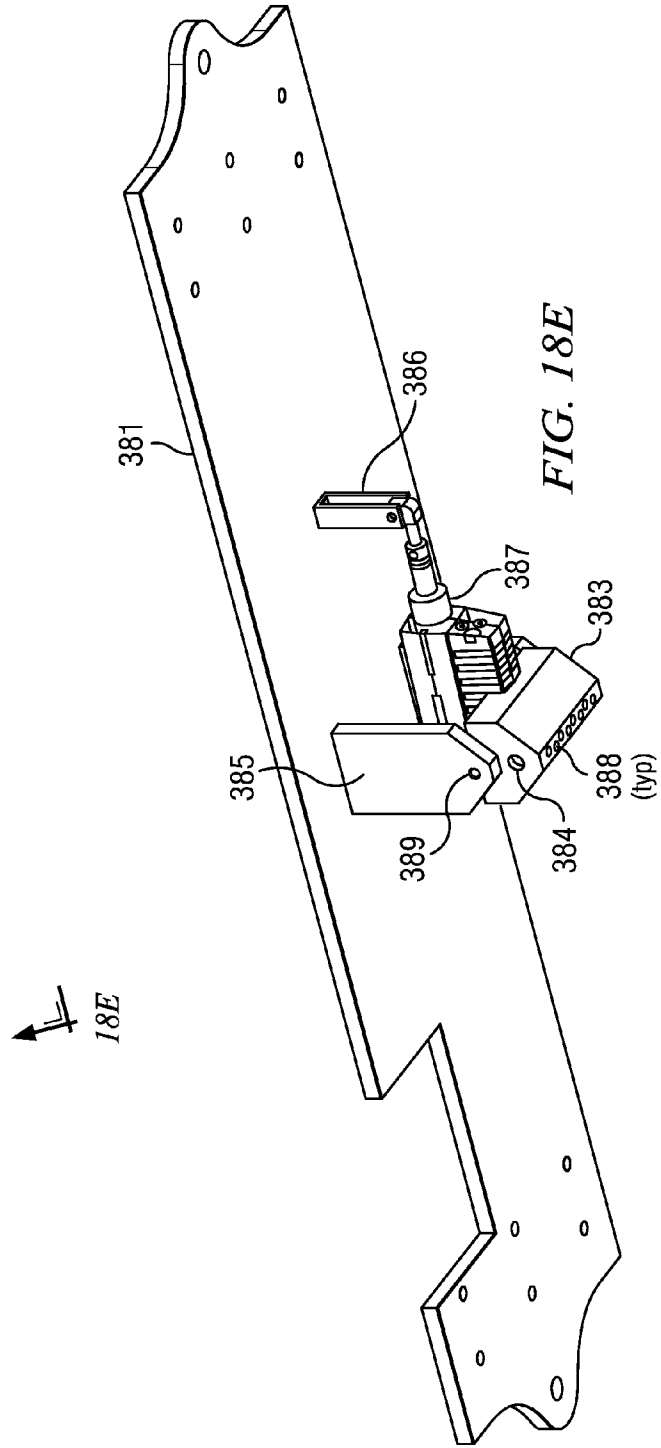
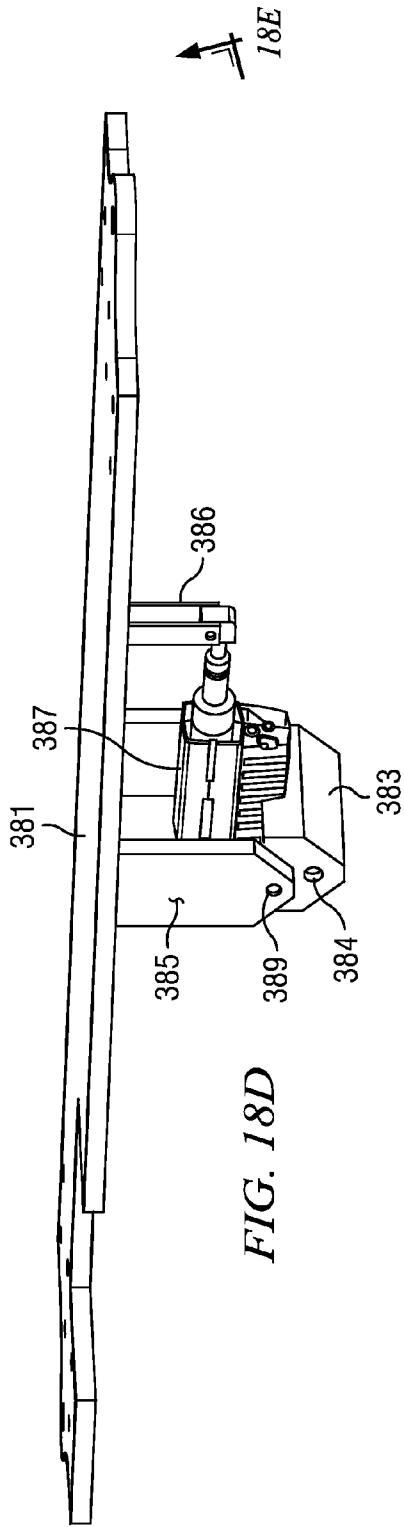
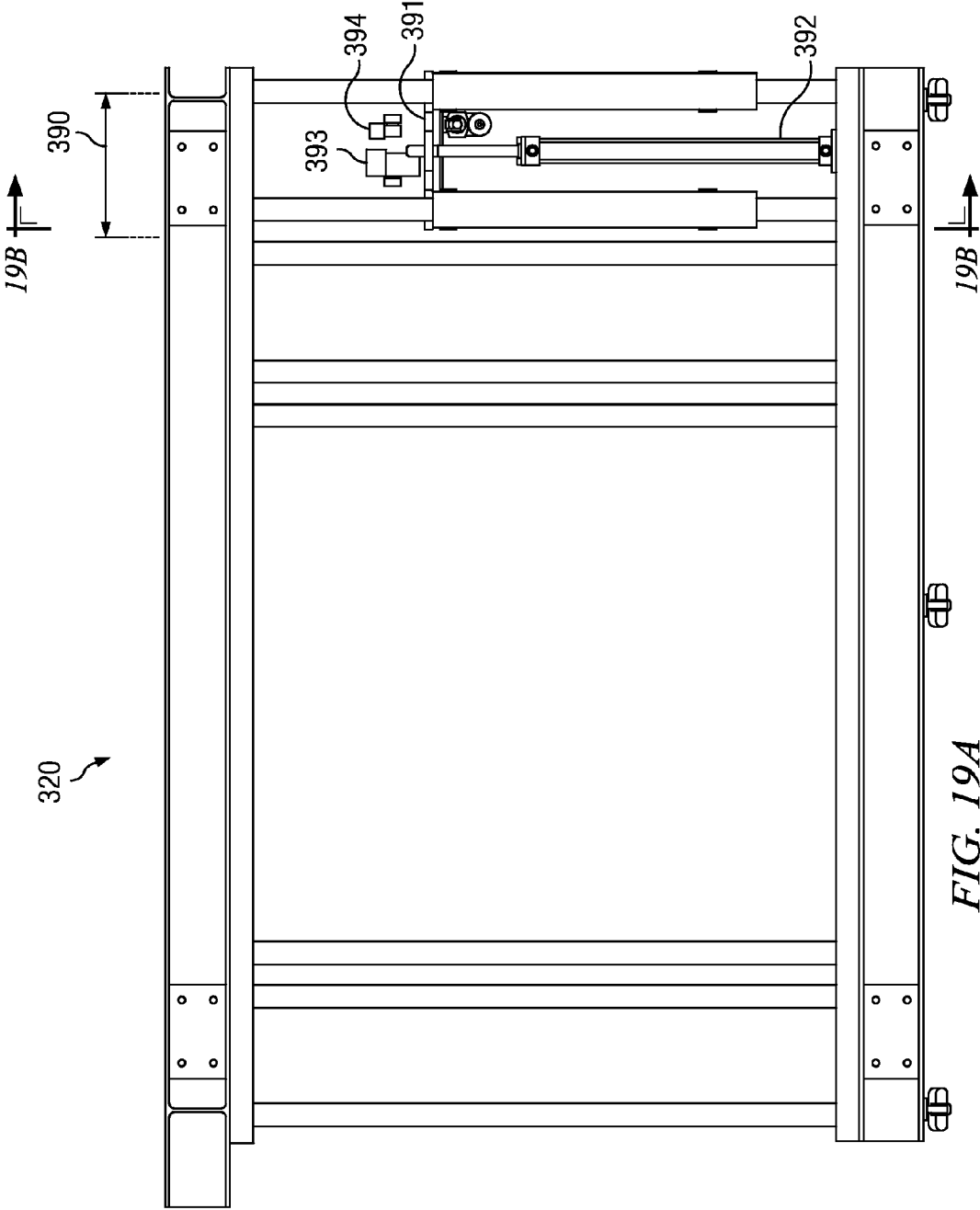

FIG. 18C





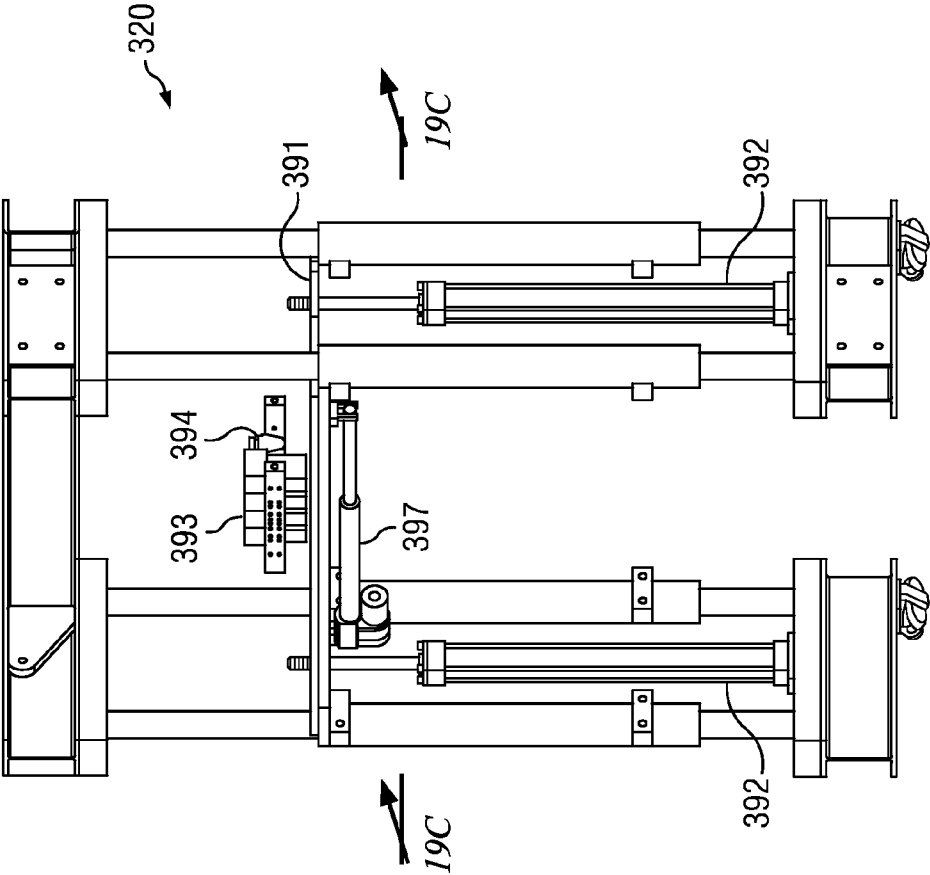
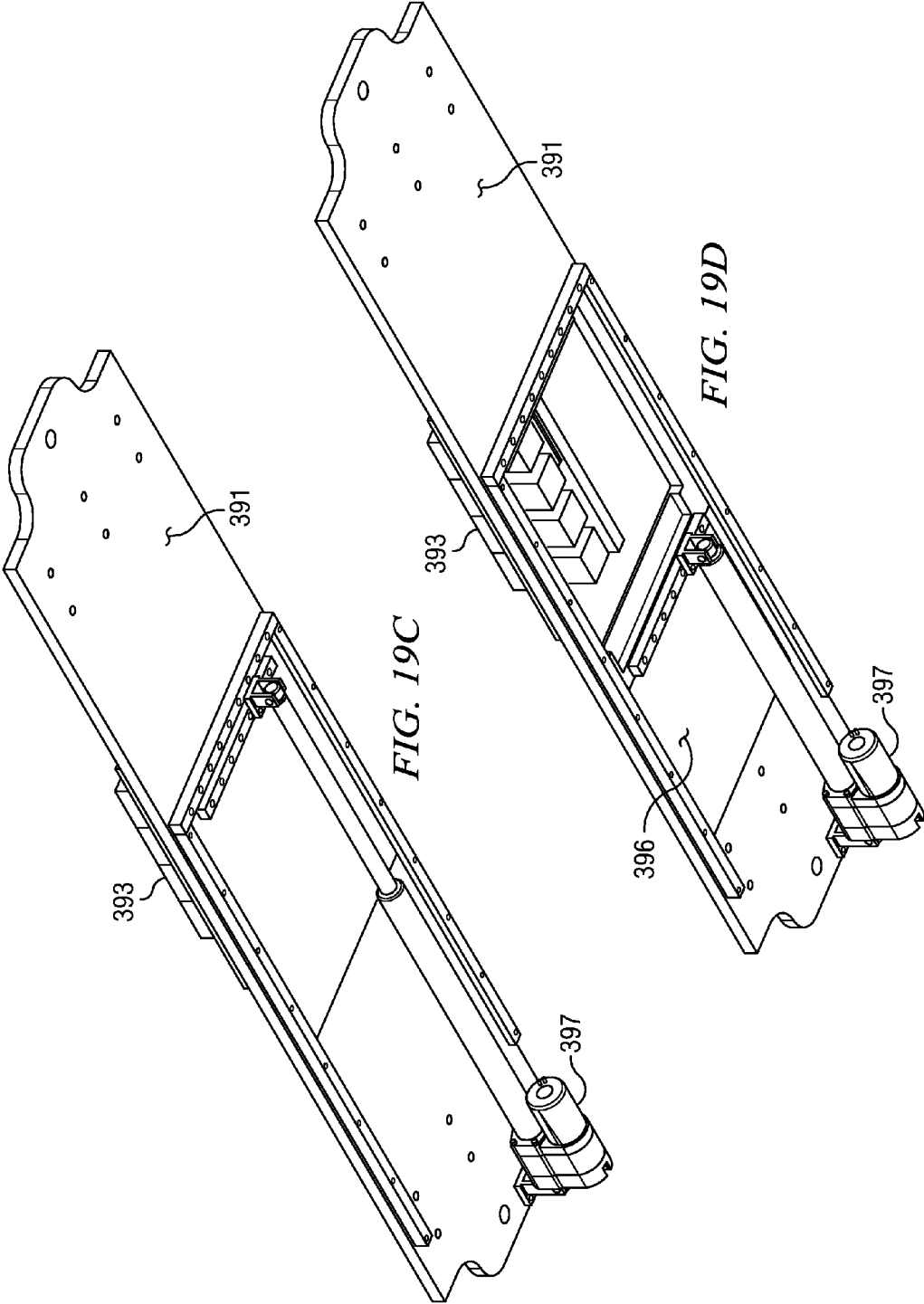

FIG. 19B



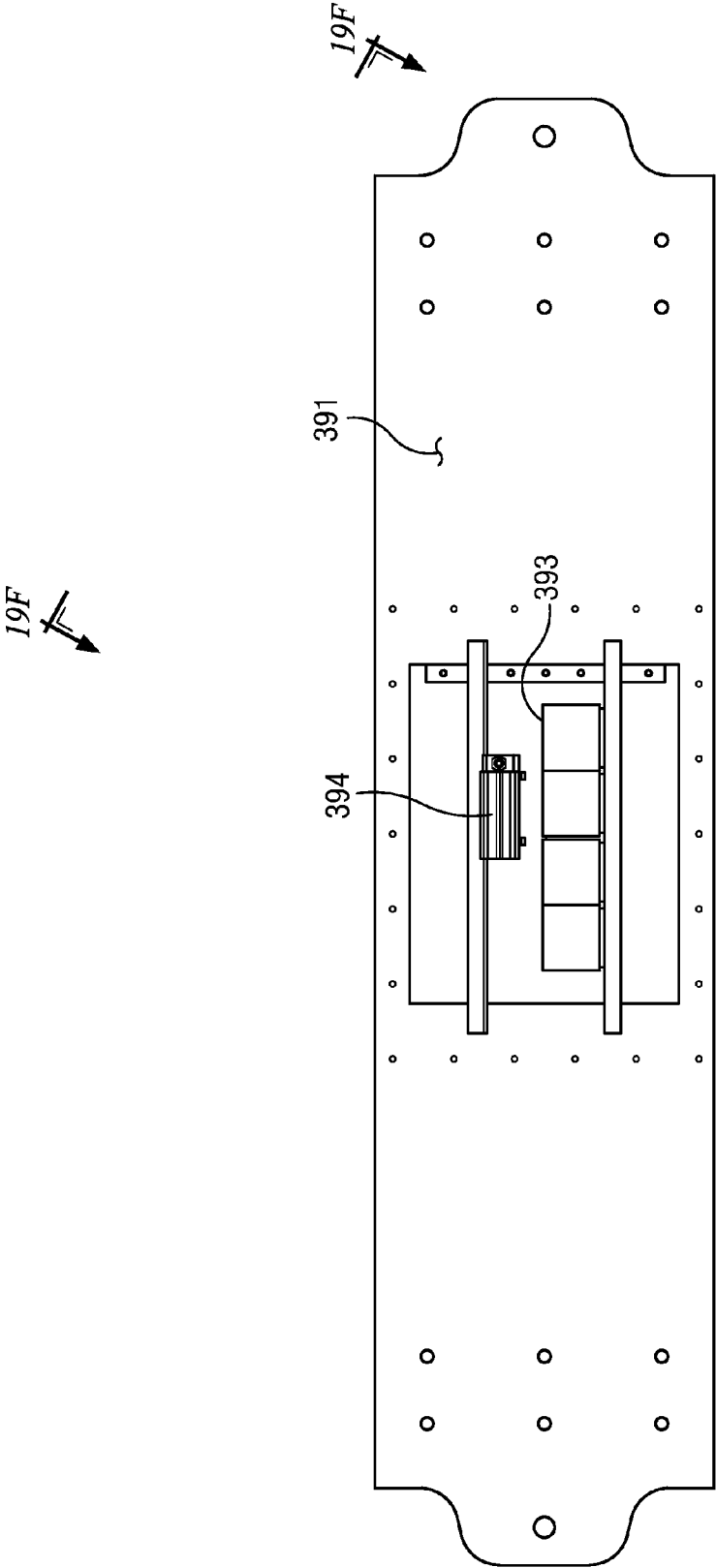

FIG. 19E

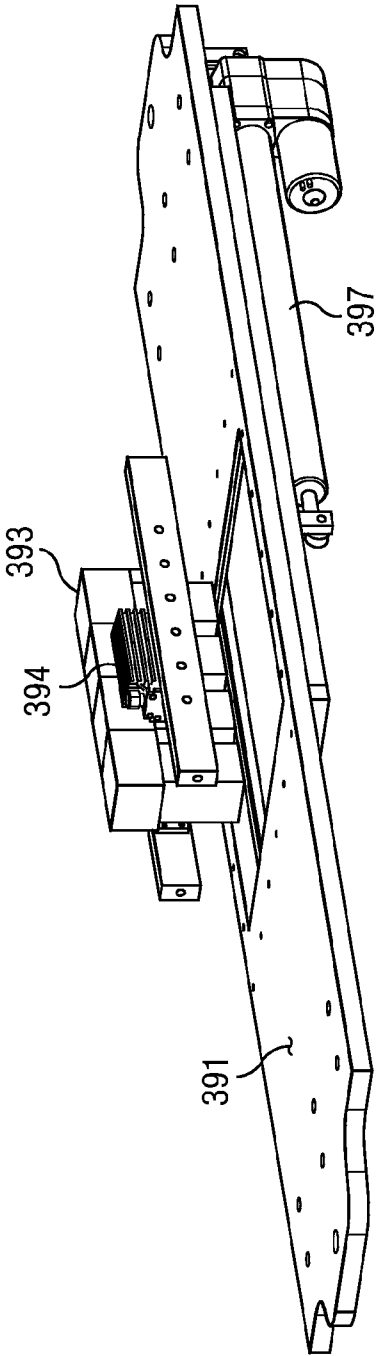

FIG. 19F

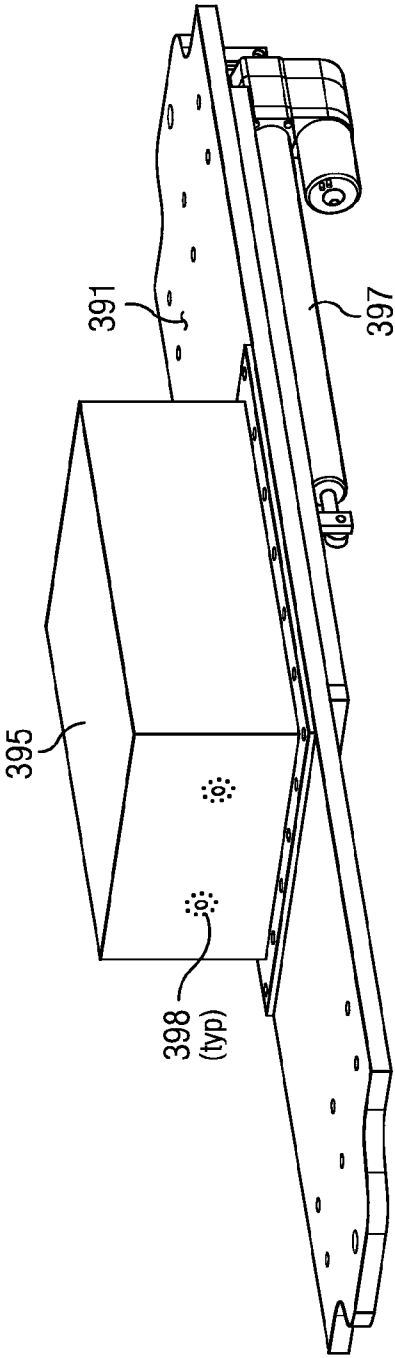

FIG. 19G

## FLOATING BRUSH TRAIN FOR EXTERNAL CLEANING OF TUBULARS

### RELATED APPLICATIONS

**[0001]** This application is a continuation of co-pending, commonly assigned U.S. patent application Ser. No. 14/042,683, filed Sep. 30, 2013, which in turn claims priority to now-expired, commonly assigned U.S. Provisional Patent Application 61/799,425, filed Mar. 15, 2013. This application claims priority to, and the benefit of, Ser. No. 14/042,683 and Ser. No. 61/799,425, and incorporates the entire disclosure of Ser. Nos. 14/042,683 and 61/799,425 by reference.

### FIELD OF THE INVENTION

**[0002]** This disclosure is directed generally to technology useful in tubular cleaning operations in the oil and gas exploration field, and more specifically to a multi-purpose buggy for cleaning and inspecting the external surfaces of tubulars such as drill pipe, workstring tubulars, and production tubulars.

### BACKGROUND

**[0003]** Throughout this disclosure, the term “Scorpion” or “Scorpion System” refers generally to the disclosed Thomas Services Scorpion brand proprietary tubular management system as a whole.

**[0004]** One drawback of conventional tubular cleaning apparatus is that, with the cleaning apparatus stationary and the tubular drawn longitudinally across, the apparatus requires a large building. Range 3 drilling pipe is typically 40-47 feet long per joint, which means that in order to clean range 3 pipe, the building needs to be at least approximately 120 feet long.

**[0005]** A further drawback of the prior art is that external cleaning operations are generally completely separate operations from inspection or other data gathering operations regarding the tubular.

### SUMMARY

**[0006]** Aspects of the Scorpion System disclosed and claimed in this disclosure address some of the above-described drawbacks of the prior art. In preferred embodiments, the Scorpion System rotates the tubular to be cleaned (hereafter, also called the “Work” in this disclosure) while keeping the Work stationary with respect to the cleaning apparatus. The Scorpion then moves the cleaning apparatus up and down the length of the Work while the Work rotates.

**[0007]** In currently preferred embodiments, the Work is typically rotated at speeds in a range of about 100-300 rpm, and potentially within a range of between about 0.01 rpm and about 1,750 rpm under certain criteria. However, nothing in this disclosure should be interpreted to limit the Scorpion System to any particular rotational speed of the Work. Currently preferred embodiments of the Scorpion System further draw the cleaning apparatus up and down the length of the Work at speeds within a range of about 0.001 linear inches per second and about and 10.0 linear feet per second, depending on the selected corresponding rotational speed for the Work. Again, nothing in this disclosure should be interpreted to limit the Scorpion System to any particular speed at which the cleaning apparatus may move up or down the length of the Work.

**[0008]** The Scorpion System provides an outer delivery system (ODS) to clean and inspect the external surface of the Work. The ODS generally comprises a “buggy”-like device that travels back and forth above the Work while the Work rotates beneath. Embodiments of the ODS are disclosed in which the buggy travels on a track. The buggy carries structure for performing operations on the external surface of the Work as the buggy travels above the Work. Such structure includes jets for delivery of fluids such as, for example, steam, fluid-borne abrasives, high and low pressure water, compressed air and drying gas (e.g. nitrogen). Such structure further includes brushes and other abrasives for abrasive cleaning or buffing. Such structure further includes data acquisition structure for inspecting and measuring the tubular, such as, for example, lasers, optical cameras, sensors and probes.

**[0009]** It is therefore a technical advantage of the disclosed ODS to clean the exterior of pipe and other tubulars efficiently and effectively. By passing different types of interchangeable cleaning apparatus on a track-mounted assembly over a stationary but rotating tubular, considerable improvement is available for speed and quality of external cleaning of the tubular over conventional methods and structure.

**[0010]** A further technical advantage of the disclosed ODS is to reduce the footprint required for industrial tubular cleaning. By moving cleaning apparatus over of a stationary but rotating tubular, reduced footprint size is available over conventional cleaning systems that move a tubular over stationary cleaning apparatus. Some embodiments of the ODS may be deployed on mobile cleaning systems.

**[0011]** A further technical advantage of the disclosed ODS is to enhance the scope, quality and reliability of inspection of the exterior of the tubular before, during or after cleaning operations. Data acquisition structure such as sensors, probes and lasers may be deployed on the track-mounted assembly passing over the stationary but rotating tubular. Such data acquisition structure may scan or nondestructively examine the exterior of the tubular, either while the tubular is rotating, and/or while the exterior is being cleaned, or otherwise.

**[0012]** A further technical advantage of the disclosed ODS is to reduce the incidence of damage to tubulars during brushing or other abrasive contact operations. Stresses occur when brushing structure passes over a rotating tubular where the tubular’s local contour or diameter is greater than nominal. The disclosed ODS provides brushing structure configured to adapt to local variations in contour and diameter of the tubular, including suspending brushes on springs in user-controllable spring equilibrium above the tubular. The brushing pressure for a nominal tubular diameter may be set, per user selection, and the spring suspensions then enable the brushing structure to adapt to local variations in contour and diameter of the tubular. The disclosed ODS also provides other contour-adapting structure such as an articulated drive shaft for a train of brushes, and a swiveling brush including an oblate spheroid-shaped brush profile.

**[0013]** A further technical advantage of the disclosed ODS is to reduce the incidence of areas or features on the external surface of the rotating tubular that may be “missed” by brushing structure as it passes by. Local variations in contour or diameter of the tubular, or sag or bow of the tubular, may cause areas of the tubular’s external surface to lose brushing contact (or lose the desired brushing pressure). The features described in the immediately preceding paragraph for brush structure to adapt to local variations in the tubular’s contour or



diameter are also useful for causing brushing structure to maintain contact (or pressure) with the external surface of the tubular when the external surface momentarily “moves away” from the brushing structure.

**[0014]** A further technical advantage of the disclosed ODS is to maintain an optimal distance between fluid jets operating on the tubular and the external surface of the tubular. Fluid jets are provided on the ODS in order deliver fluids (in liquid or gaseous state) for cleaning and other operational purposes. An electronic control system gathers real time data regarding the local contours in the tubular’s external surface and maintains an optimal distance between the fluid jets and the external surface, so that the operating effectiveness of the fluid jets is maximized without causing damage to the tubular’s surface.

**[0015]** The foregoing has outlined rather broadly some of the features and technical advantages of the present invention in order that the detailed description of the invention that follows may be better understood. Additional features and advantages of the invention will be described hereinafter which form the subject of the claims of the invention. It should be appreciated by those skilled in the art that the conception and the specific embodiment disclosed may be readily utilized as a basis for modifying or designing other structures for carrying out the same purposes of the present invention. It should be also be realized by those skilled in the art that such equivalent constructions do not depart from the spirit and scope of the invention as set forth in the appended claims.

#### BRIEF DESCRIPTION OF THE DRAWINGS

**[0016]** For a more complete understanding of the present invention, and the advantages thereof, reference is now made to the following descriptions taken in conjunction with the accompanying drawings, in which:

**[0017]** FIG. 1 is a functional-level general arrangement of one embodiment of the ODS in a combination deployment with an MLI 100;

**[0018]** FIG. 2 is an enlargement of FIG. 1 in isometric view;

**[0019]** FIG. 3 depicts the underside of one embodiment of the ODS from the view of arrow 210 on FIG. 2;

**[0020]** FIG. 4 illustrates one embodiment of the ODS in elevation view;

**[0021]** FIG. 5 illustrates another embodiment of the ODS in elevation view;

**[0022]** FIG. 6 is an end view as shown on FIG. 5;

**[0023]** FIG. 7 illustrates the ODS embodiment of FIG. 5 disposed to operate on tubular W;

**[0024]** FIGS. 8 and 9 illustrate the ODS embodiment of FIGS. 5-7 in different isometric views;

**[0025]** FIG. 10 is a further isometric view of ODS embodiment of FIGS. 5-7, with a propulsion drive and track detail added;

**[0026]** FIG. 11 is an isolated elevation view of fixed brush train 240;

**[0027]** FIGS. 12A and 12B are isolated elevation views of swivel brush assembly 260;

**[0028]** FIG. 12C is a cutaway view of swivel brush assembly 260;

**[0029]** FIGS. 12D and 12E are stroboscopic views of swivel brush assembly 260;

**[0030]** FIGS. 13A and 13B are isolated elevation views of fluid jet assembly 280;

**[0031]** FIG. 14 is an isometric view of ODS buggy 320, an alternative embodiment to the buggy aspects of ODS assembly 220 illustrated generally on FIG. 5;

**[0032]** FIGS. 15A, 15B, 15C and 15D are elevation views of ODS buggy as shown on FIGS. 14 and 15A;

**[0033]** FIG. 16A isolates brush train 340 from the elevation view of FIG. 15C;

**[0034]** FIG. 16B is an isometric view of the section shown on FIG. 16A;

**[0035]** FIGS. 16C, 16D and 16E show aspects of brush train 340 close-up in isolation, in which FIGS. 16C and 16D are isolated from FIGS. 15C and 15D respectively, and FIG. 16E is an isometric view as shown generally on FIG. 16D;

**[0036]** FIGS. 17A, 17B and 17C are isolated views of swivel brush assembly 360, in which FIGS. 17A and 17B are isolated from FIGS. 15C and 15A respectively, and FIG. 17C is an isometric view of FIG. 17A;

**[0037]** FIGS. 18A and 18B are isolated views of fluid jet assembly 380, in which FIGS. 18A and 18B are isolated from FIGS. 15C and 15B respectively;

**[0038]** FIG. 18C is an isometric view of the section shown on FIG. 18A;

**[0039]** FIGS. 18D and 18E show aspects of fluid jet assembly 380 close-up in isolation, in which FIG. 18D is an enlargement of the isometric view of FIG. 18C, and FIG. 18E is an isometric view shown generally on FIG. 18D;

**[0040]** FIG. 19A is an isolated view of camera assembly 390, in which FIG. 19A is isolated from FIG. 15C;

**[0041]** FIG. 19B is an isometric view of the section shown on FIG. 19A;

**[0042]** FIGS. 19C and 19D show aspects of camera assembly in close-up isolation, in which FIG. 19C is shown generally on FIG. 19B, and in which FIG. 19D is the same as FIG. 19C except with sliding door 396 illustrated as open;

**[0043]** FIG. 19E is a plan view of FIG. 19D; and

**[0044]** FIGS. 19F and 19G are further isometric views of aspects of camera assembly 390 in close-up isolation, in which FIG. 19F is shown generally on FIG. 19E, and FIG. 19G is the same as FIG. 19F except with containment cover 395 in place.

#### DETAILED DESCRIPTION

**[0045]** FIGS. 1 through 4 illustrate a first embodiment of an ODS assembly (or “buggy”), designated generally on FIGS. 1 through 4 as ODS assembly 201. FIGS. 5 through 13B illustrate a second embodiment of an ODS assembly, designated generally on FIGS. 5 through 13B as ODS assembly 220. Nothing in this disclosure should be interpreted to limit the ODS to the embodiments of ODS assemblies 201 and 220 or the structural features and aspects disclosed thereon.

**[0046]** FIG. 1 is a general arrangement drawing that illustrates, in an elevation view, an exemplary embodiment in which the ODS assembly 201 is disposed above tubular W (the Work). It will be seen and understood on FIG. 1 that ODS assembly 201 travels along track 202 while tubular W rotates. As will be described in greater detail further on, ODS assembly 201 provides a plurality of shrouded heads 203 comprising tooling that may perform a user-selected sequence of operations (including cleaning and data acquisition operations) on tubular W. As ODS assembly 201 travels along track 202 while tubular W rotates, it will be seen from FIG. 1 that ODS assembly 201 enables such user-selected sequence of

operations by providing heads and associated tooling in a corresponding sequence as ODS assembly **201** comes to bear upon tubular **W**.

[0047] The exemplary embodiment illustrated in FIG. 1 also shows, solely for reference purposes, guide tubes **101** from a Multi-Lance Injector (MLI) assembly **100** in “curved tube” mode, as is fully disclosed in U.S. Provisional Application Ser. No. 61/707,780, priority to which Provisional Application is claimed herein (see disclosure in such Provisional Applications under the heading “Interior Cleaning of the Work”). In this way, FIG. 1 illustrates an embodiment of the Scorpion System, in which both MLI structure and ODS structure are provided together in one machine. It will be appreciated however, that nothing in this disclosure should be interpreted to require that MLI structure be combined with ODS structure in one machine. Other embodiments, not illustrated or described in this disclosure in any detail, may provide MLI structure and/or ODS structure in stand-alone machines

[0048] Referring again to FIG. 1, it will be understood that certain conventional structure has been omitted for clarity. For example, ODS assembly **201**, track **202** and guide tubes **101**, for example, are advantageously supported by structural steel and other conventional support means (including, in some embodiments, a gantry for maintenance access), all of which has been omitted for clarity. Operation of the ODS is advantageously accomplished using conventional hydraulic, pneumatic or electrical apparatus (including geared drive motor apparatus to cause ODS assembly **201** to travel track **202** as illustrated by arrow **204** on FIG. 1), all of which has been also omitted for clarity.

[0049] Turning now to FIG. 2, an embodiment of ODS assembly **201** is illustrated in more detail. It will be appreciated that FIG. 2 is a perspective view of the embodiment shown on FIG. 1, looking back at ODS assembly **201** from tubular **W**, slightly from underneath. The embodiment of FIG. 2 illustrates ODS assembly **201** operable to move up and back along track **202** via motorized gear wheels **208** on either side of ODS assembly **201** (only one side’s gear wheel **208** visible on FIG. 2), whereby motorized gear wheels **208** run in geared rails **209** deployed on track **202**. It will be understood, however, that the motorized gear propulsion mechanism for ODS assembly **201** illustrated on FIG. 2 is exemplary only, and any other operable propulsion mechanism for ODS assembly **201** is within the scope of this disclosure.

[0050] FIG. 2 also depicts shrouded heads **203** in more detail. Each of shrouded heads **203** comprises tooling surrounded by a shroud. A primary purpose of the shroud is to prevent by-products from the operation of the tooling (e.g. steam, water, dirt and rust removed from the outside of tubular **W**) from dispersing excessively into the airspace surrounding ODS assembly **201**.

[0051] The tooling included in shrouded heads **203** is user-selectable according to operational needs. In the exemplary embodiment illustrated in FIG. 2, shrouded heads **203** comprise nozzle head **205**, then six abrasive heads **206**, and then probe head **207**. Nothing in this disclosure should be interpreted, however, to limit the ODS to any particular type or amount of tooling, or the number of shrouded heads on which it is embodied, or the sequence in which it is brought to bear on tubular **W**.

[0052] Reference is now made to FIG. 3, which illustrates the tooling in the exemplary embodiment of FIG. 2 in more detail. FIG. 3 depicts shrouded heads **203** as also shown on

FIGS. 1 and 2 from underneath, in the direction of arrow **210** as shown on FIG. 2. Nozzle head **205**, abrasive heads **206** and probe head **207** may be seen on FIG. 3, as also seen on FIG. 2. FIG. 3 also depicts each shrouded head **203** comprising tooling surrounded by a shroud (the shrouds labeled reference numeral **211** on FIG. 3).

[0053] Referring back briefly to FIGS. 1 and 2 together, it will be seen that when ODS assembly **201** begins its travel in the direction of arrow **204** on FIG. 1 and comes to bear on tubular **W**, the currently preferred embodiment of the ODS provides nozzle head **205** as the first of shrouded heads **203** to operate on tubular **W**. Abrasive heads **206** follow nozzle head **205**, and probe head **207** follows abrasive heads **206**. This exemplary user-selected sequence of shroud heads **203** reflects the following sequence of tubular cleaning and data acquisition operations (although nothing herein should be construed to limit the ODS to the following operational sequence):

[0054] Nozzle Head **205**—First Nozzle Group:

[0055] High pressure water blast (nominally at about 20,000 psi but not limited to any such pressure) for concrete removal and general hydroblasting operations, especially if tubular **W** has a severely rusted or scaled outer surface.

[0056] Nozzle Head **205**—Second Nozzle Group:

[0057] Low pressure/high temperature wash, nominally at 3,000 psi/300 deg F but not limited to any such pressure or temperature), for general tubular cleaning operations, including salt wash and rust inhibitor coating.

[0058] Abrasive Heads **206**:

[0059] Abrasive surface cleaning and treatment of outer surface of tubular **W** via steel wire brush and/or flap wheels for removal, for example, of protruding steel burrs on the outer surface of tubular **W**.

[0060] Probe Head **207**:

[0061] Data acquisition devices and/or sensors examining outer surface of tubular **W**.

[0062] Looking now at FIG. 3 in greater detail, it will be seen that nozzle head **205** comprises one or more nozzles **212**. FIG. 3 depicts four (4) nozzles **212**, in a line off center. However, such configuration of nozzles **212** on FIG. 3 is exemplary only, and nothing in this disclosure should be construed to limit nozzle head **205** to provide any particular number of nozzles **212** in any particular configuration. Other embodiments, consistent with the scope of this disclosure, might provide fewer or greater than four (4) nozzles **212**, and might deploy them on center or in different locations off center.

[0063] Relating nozzle head **205** as shown on FIG. 3 to the exemplary ODS operational sequence described above, it will be seen that nozzles **212** on nozzle head **205** may enable both the high pressure wash and the low pressure wash. It will be further appreciated that different embodiments of nozzle head **205**, wherein each nozzle head **205** provides different numbers, locations and configurations of nozzles **212**, may enable different combination of operations (such as steam clean, wash, rinse, spray, coat, etc.) according to user selection.

[0064] Relating abrasive heads **206** as shown on FIG. 3 to the exemplary ODS sequence described above, it will be appreciated that abrasive heads **206** may provide steel brushes, rattling heads, flap wheels or any other abrasive tooling in any combination or sequence to further clean, treat or smooth the outer surface of tubular **W**. FIG. 3 depicts abrasives **213** on abrasive heads **206** in generic form for this

reason. In a currently preferred embodiment of the ODS, for example only, the three (3) abrasive heads **206** nearest nozzle head **205** provide abrasives **213** in the form of rotating steel brushes, while the three (3) abrasive heads **206** nearest probe head **207** provide abrasives **213** in the form of rotating flap wheels. In this embodiment, optionally, a nozzle **212** on neighboring nozzle head **205**, or on any of abrasive heads **206** themselves, may also be provided and dedicated to cleaning the steel brushes embodying abrasives **213**. Nothing in this disclosure should be construed, however, to limit the ODS to this embodiment, or to any configuration, type or number of abrasives **213** or abrasive heads **206**.

**[0065]** Probe head **207** as shown on FIG. 3 provides data acquisition probes and sensors for examining and acquiring information about tubular W's outer surface, condition, wall thickness and other parameters. This examination and information gathering process is disclosed in greater detail below in paragraphs near the end of this disclosure describing the Data Acquisition System ("DAS"). Probe head **207** may provide all types of sensors, including, without limitation, magnetic, ultrasonic, laser and other types of sensors. Nothing in this disclosure should be interpreted to limit the type or number of sensors provided by probe head **207**.

**[0066]** Although not illustrated, other embodiments of the ODS may supplement the data acquisition capability of probe head **207** by optionally providing additional sensors on the inside of shrouds **211**. For reference, shrouds **211** are called out on FIG. 3.

**[0067]** Sensor data from probe head **207** and shrouds **211** may be further enhanced or supplemented by the optional addition of imaging technology positioned to scan tubular W's outer surface during ODS operations (such optional imaging technology not illustrated). For example, a thermal imaging camera ("infrared thermography") may be used to detect, record and quantify temperature differentials in the outer surface of tubular W. Such temperature differentials may typically (1) indicate excess moisture found in cracks and pores in tubular W, and (2) measure rates of heat exchange in steel densities and volumes. The imaging data may thus be used easily and conventionally to detect cracks, thickness variations, and porosity in the wall or on the surface of tubular W.

**[0068]** Advantageously, the imaging data may be in the form of a Gaussian (i.e. rainbow) color swath, conventionally displaying lower temperatures in "cooler" colors such as blue, green and cyan, and higher temperatures in "hotter"/"brighter" colors such as red, yellow and magenta. Anomalies in tubular W such as a surface crack, subsurface crack, porous pipe wall (i.e. less dense wall), and/or variation in wall thickness may be identified via detection of a corresponding temperature gradient (caused by excess moisture and thus lower temperatures in and around the anomaly) when compared to the temperature gradient of a healthy/continuous run of steel. While such temperature gradient analysis is available at ambient temperatures, the sensitivity (and corresponding efficacy) of the analysis is enhanced if hot water is applied prior to scanning.

**[0069]** Referring back now to FIG. 1, it will be appreciated that although not illustrated in FIG. 1, the Scorpion System's ODS is operable via conventional positioning apparatus to position tubular W with respect to ODS assembly **201** ready for operations. In a preferred embodiment, such positioning apparatus may move ODS assembly **201** with respect to tubular W so as to correctly position the operational tooling on

ODS assembly **201** with respect to the external surface of tubular W. In other embodiments, such positioning apparatus may alternatively, or also, position the tubular W with respect to ODS assembly **201**.

**[0070]** FIG. 4 illustrates additional, more precise positioning apparatus once ODS assembly **201** is initially positioned with respect to tubular W by conventional positioning apparatus, per the previous paragraph. FIG. 4 is an enlargement of ODS assembly **201** shown more generally on FIG. 1, and depicts aspects of ODS assembly **201** in greater detail. FIG. 4 further depicts ODS assembly **201**, nozzle head **205**, abrasive heads **206**, probe head **207** and gear wheel **208** consistent with the correspondingly-numbered features shown on FIGS. 1 and 2 (and such features' accompanying disclosure herein).

**[0071]** Referring now to FIG. 4, it will be seen that nozzle head **205** is suspended on nozzle head piston **215**, while probe head **207** is suspended on probe head piston **217**. Abrasive heads **206** generally, as a group, are suspended on abrasive head piston **216**. Abrasive heads **206** are then further suspended individually via corresponding abrasive head springs **214**. In this way, each of nozzle head **205**, abrasive heads **206** and probe head **207** may be more precisely positioned, independently of one another, with respect to the outer surface of tubular W (tubular W omitted for clarity on FIG. 4) according to user selection.

**[0072]** With respect to nozzle head **205**, FIG. 4 shows that independent extension and retraction of nozzle head piston **215**, as required, will allow nozzle head **205** to be positioned to a precise user-selected location above the outer surface of tubular W. Likewise, FIG. 4 shows that independent extension and retraction of probe head piston **217**, as required, will allow probe head **207** to be positioned to a precise user-selected location above the outer surface of tubular W.

**[0073]** With respect to abrasive heads **206**, as a group, FIG. 4 shows that extension and retraction of abrasive head piston **216** will allow abrasive heads **206**, as a group, to be positioned to a precise user-selected location above the outer surface of tubular W. Further, via compression and release of abrasive head springs **214**, FIG. 4 shows that abrasives **213** on abrasive heads **206** (see FIG. 3) may be kept in spring pressure contact with the outer surface of tubular W while abrasive heads **206** operably move along tubular W. Further, the independent suspension of each abrasive head **206** on its own abrasive head spring **214** allows each abrasive head **206** (and corresponding abrasives **213**) to conform to the local shape or contour of the outer surface of tubular W as it operably moves along tubular W.

**[0074]** Although FIG. 4 illustrates an embodiment of ODS assembly **201** in which each abrasive head **206** has one corresponding abrasive head spring **214**, it will be understood that the scope of this disclosure is not limited in this regard. It will be appreciated that suspension on additional springs may allow individual abrasive heads **206** to conform yet more closely (e.g., via pivoting) to the local shape or contour of the outer surface of tubular W as it operably moves along tubular W. In other embodiments, some described with reference to FIGS. 5 through 11, neighboring individual abrasive heads **206** may be connected together via, for example, an articulated connection, to create a similar effect.

**[0075]** Referring again to nozzle head piston **215**, abrasive head piston **216** and probe head piston **217** on FIG. 4, it will be understood that the scope of this disclosure is not limited to extending or retracting these pistons to position their corresponding heads solely prior to commencing operations. It will

be appreciated that further extensions or retractions of pistons **215**, **216** and/or **217** may alter, as required, the precise position of nozzle head **205**, abrasive heads **206** and probe head **207** with respect to the outer surface of tubular **W** while ODS assembly **201** is moving with respect to tubular **W**. It will be further understood, however, that in some embodiments, lasers and magnetic proximity sensors (not illustrated) are a primary means of adjustment for contours in the outer surface of tubular **W**, rather than extensions or retractions of pistons **215**, **216** and/or **217** on the fly.

[0076] Reference is now made to FIGS. **5** through **13B**, which illustrates ODS assembly **220** as an alternative embodiment to ODS assembly **201** as illustrated on FIGS. **1** through **4**. It will be appreciated that the disclosure above to general principles, features and aspects of the ODS, regardless of the embodiment of ODS assembly or “buggy”, applies equally to the embodiments disclosed below with reference to FIGS. **5** through **13B**.

[0077] Further, for the avoidance of confusion on FIGS. **5** through **13B**, it will be understood that, for illustration purposes on this disclosure only, alternative ODS assembly embodiments **201** and **220** are illustrated to run in opposite directions from a default rest position (such default resting position defined for purposes of this paragraph only as resting ready to begin engaging a tubular). ODS assembly **201** embodiment on FIGS. **1** through **4** is illustrated to run right-to-left on the page from a default rest position (see arrow **204** on FIG. **1** and associated disclosure above). In contrast, ODS assembly **220** embodiment of FIGS. **5** through **13B** is illustrated to run left-to-right on the page from such a default rest position.

[0078] Thus, with reference to FIG. **5**, as ODS assembly **220** moves and engages a tubular beneath, ODS laser **222** first detects the end of the tubular and then ODS laser **222**'s field of view **223** begins to scan the external surface of the tubular below as the tubular rotates. Information from scanning by ODS laser **222** is used by ODS assembly **220**'s control system (not illustrated) to inspect and analyze characteristics of the tubular as described in greater detail below. Currently-preferred embodiments of ODS assembly **220** further include an optical camera also deployed in combination with ODS laser **222**. The optical camera also scans the tubular beneath within field of view **223** as illustrated on FIG. **5** (and other Figures) and receives corresponding images of the tubular for processing in combination with information from ODS laser **222**. For the avoidance of doubt, the term “ODS laser **222**” as used hereafter in this disclosure refers to a combination of a laser and an optical camera scanning the tubular in field of view **223**. The operation of the laser and optical scanner in combination is discussed further below in this disclosure.

[0079] FIG. **5** further depicts ODS assembly **220** providing fluid jet assembly **280** next to ODS laser **222**. Fluid jet assembly **280** provides jets **282**, which spray or blast fluids (in gaseous or liquid state) onto the external surface of a rotating tubular beneath. Individual jets **282** are user-selectable according to operational needs. By way of example only, and without limitation, jets **282** may provide: (1) a steam blast, a high pressure water blast (nominally at about 20,000 psi but not limited to any such pressure) or even a fluid-borne abrasive blast for operations such as concrete removal or hydro-blasting operations, especially if tubular **W** has a severely rusted or scaled outer surface; (2) a low pressure/high temperature wash (nominally at 3,000 psi/300 deg F but not limited to any such pressure or temperature), for general

tubular cleaning operations, including salt wash and rust inhibitor coating; and/or (3) a compressed air or gas (such as nitrogen) blast, for drying or (in the case of compressed air) removal of surface debris. Fluid jet assembly **280** is described in greater detail below with reference to FIGS. **13A** and **13B**.

[0080] FIG. **5** further depicts swivel brush assembly **260** next to fluid jet assembly **280** on ODS assembly **220**. Swivel brush assembly **260** provides swivel brush **262** (which may, per further disclosure below, be a laminate of planar brushes) at the point of contact with the external surface of a rotating tubular beneath. Swivel brush assembly **260** further provides axle structure and conventional power apparatus (such as hydraulic, electric or pneumatic motors) to power-rotate the swivel brush **262** at user-selected speeds on user-selected speed cycles. Swivel brush **262** may be of any suitable size, profile or construction, per user selection, and this disclosure is not limited in this regard. In the embodiments illustrated on FIGS. **5** through **13B**, swivel brush assembly **260** provides one swivel brush **262** having an oblate spheroid shape and profile, although swivel brush **262** is not limited to a single brush in other embodiments.

[0081] Swivel brush assembly **260** may further be rotated, per user control and selection, about its vertical axis **261** as shown on FIG. **5**. In this way, swivel brushes (including, on FIG. **5**, swivel brush **262**) may be caused to abrade the external surface of a tubular at any user-selected angle relative to the axis of the tubular's rotation. Changes may be made to the angle of abrasion on the fly. This feature acknowledges that certain common oilfield tubulars, such as drill pipe, are conventionally turned in a clockwise direction as drilling into the earth progresses. This drilling rotation causes helical scratching and scarring on the external surface of the tubular. The ability to set and adjust the angle of abrasion on swivel brush assembly **260** permits a more effective cleaning of external surfaces that may have a helical scratch or scar pattern.

[0082] Swivel brush assembly **260** on FIG. **5** is also disposed to “tilt” or pivot so that swivel brush **262** follows the contour of a rotating tubular beneath. Such “tilting” or pivoting is about a substantially horizontal axis. Once the general height of swivel brush assembly **260** above a tubular is set, “tilting” or pivoting structure takes over to allow swivel brush assembly **260** to follow the contour of the tubular, while spring structure on swivel brush assembly **260** permits the swivel brush (or brushes) to maintain a substantially constant contact on the surface of the tubular as they pass over local variations in the tubular's diameter. Swivel brush assembly **260** (including the “tilting”/pivoting feature and the contouring feature) is described in greater detail below with reference to FIGS. **12A** through **12E**.

[0083] FIG. **5** further depicts fixed brush train **240** next to swivel brush assembly **260** on ODS assembly **220**. Fixed brush train **240** comprises fixed brushes **242**, each configured to rotate generally about an axis parallel to the longitudinal axis of a tubular beneath. In illustrated embodiments, fixed brushes **242** provide circular (“wheel”-like) brushes at the point of contact with the external surface of a rotating tubular beneath. Fixed brush train **240** further connects fixed brushes **242** together into a concatenated train thereof via articulated brush joints **244**. Embodiments of articulated joints may include conventional u-joints or any other structure suitable for connecting neighboring fixed brushes **242** in articulated fashion. As shown on FIG. **5** (and subsequent Figures), articulated brush joints **244** form an articulated drive shaft which drives fixed brushes **242** to rotate in unison. Individual fixed

brushes 242 are thus permitted to move vertically semi-independently of one another, while still all being driven in unison by the articulated drive shaft formed by articulated brush joints 244. Conventional power apparatus (such as hydraulic, electric or pneumatic motors) at either or both ends of fixed brush train 240 may power-rotate all of the fixed brushes in unison at user-selected speeds on user-selected speed cycles. Fixed brushes 242 may be of any suitable number, size, profile or construction, per user selection, and this disclosure is not limited in this regard. In the embodiments illustrated on FIGS. 5 through 11, fixed brushes 242 have a conventional cylindrical shape and profile. Alternatively one or more fixed brushes 242 may have the oblate spheroid (“football”) shape described above with respect to swivel brush 262 elsewhere in this disclosure, or any user-selected design. It will be also understood that this disclosure is not limited to the number of fixed brushes 242 that may be deployed on fixed brush train 242. In the embodiments illustrated on FIGS. 5 through 13B, fixed brush train 240 provides five (5) fixed brushes 242 concatenated into an articulated train, separated by articulated brush joints 244 and driven by two fixed brush motors 246. Nothing in this disclosure should be interpreted, however, to limit fixed brush train 240 to any specific number of fixed brushes 242 and/or brush motors 246.

[0084] The concept of the term “fixed” on fixed brush train 240 (as opposed to the term “swivel” on swivel brush assembly 260 described above) refers to the fact that fixed brushes 242 on fixed brush train 240 do not rotate about a vertical axis normal to the axis of rotation of the tubular, and are further constrained from doing so by the interconnection provided by articulated brush joints 244. Fixed brushes 242 on fixed brush train 240 instead form a series of abrading surfaces that rotate in unison on the external surface of the rotating tubular beneath, where the angle of abrasion is consistently normal to the longitudinal axis of the tubular.

[0085] FIG. 5 further illustrates that fixed brush train 240 suspends fixed brushes 242 from shock absorbers 248. In the embodiments illustrated on FIGS. 5 to 13B, shock absorbers 248 are spring mechanisms, and fixed brush train 240 provides one shock absorber 248 for each fixed brush 242, although this disclosure is not limited in this regard. It will be appreciated from FIG. 5 that shock absorbers 248 further regulate the semi-independent vertical movement provided to each fixed brush 242 by articulated brush joints 244. The semi-independent vertical movement permits each individual fixed brush 242 the independent freedom to follow the local contour of the rotating tubular beneath as fixed brushes 242 pass over the tubular. Fixed brush motors 246 may nonetheless still drive all fixed brushes 242 in unison. Shock absorbers 248 regulate the independent vertical movement of each fixed brush 242, requiring each fixed brushes 242 to maintain a substantially constant contact on the surface of the tubular as it passes over local variations in the tubular’s diameter. Once the general height of fixed brush train 240 above a tubular is set, shock absorbers 248 take over to allow each fixed brush 242 to follow the local contour of the tubular as it passes by beneath. Fixed brush train 240 is described in greater detail below with reference to FIG. 11.

[0086] It should be noted that although the above disclosure has referred, with respect to FIG. 5, to swivel brush assembly 260 and fixed brush train 240, nothing in this disclosure should be interpreted to limit swivel brush assembly 260 and fixed brush train 240 to “brushes” in the sense of an abrasion tool with bristles. Swivel brush 262 and fixed brushes 242

may be any abrasive tool, including, but not limited to, wire brushes, flap wheels, or abrasive stone or composite wheels.

[0087] FIG. 5 further illustrates top shroud 250 covering structure above fixed brush train 240, swivel brush assembly 260 and fluid jet assembly 280. Top shroud 250 protects against steam, dust, debris, fluid overspray and other by-products of cleaning operations below. Fluid jet assembly 280 is also advantageously covered by a shroud (omitted on FIGS. 5 through 13B for clarity) during operations in order to contain steam, fluid overspray, debris, etc., caused by the operation of jets 282. A further containment structure advantageously deployed about the entire operation of ODS assembly 220 (again, omitted on FIGS. 5 through 13B for clarity) restrains steam, fluid overspray, dust, debris, etc. from contaminating the general surroundings, and further enables recycling of recyclable fluids after jets 282 may have administered them.

[0088] FIG. 6 is an end view of ODS assembly 220 as shown on FIG. 5. FIG. 6 illustrates features and aspects of ODS assembly 220 as also shown on FIG. 5. FIG. 6 also illustrates features and aspects of ODS assembly 220 that were omitted from FIG. 5 for clarity. Fluid jet assembly 280, however, which was shown and described above with reference to FIG. 5, is omitted for clarity from FIG. 6 so that features and aspects of swivel brush assembly 260 may be better seen.

[0089] FIG. 6 depicts ODS assembly with top shroud 250, ODS laser 222 and laser field of view 223, as described above more fully with reference to FIG. 5. Swivel brush assembly 260 may also be seen on FIG. 6, including swivel brush 262, as also described above with reference to FIG. 5. It will be seen on FIG. 6 more clearly that in the ODS assembly embodiment of FIGS. 5 through 13B, swivel brush 262 has been user-selected to be in the shape and profile of an oblate spheroid (although swivel brush 262 as disclosed herein is not limited to such a shape and profile). The oblate spheroid shape may be created by laminating together a plurality of planar circular brushes of gradually varying diameter. The laminate may vary from smallest diameter at the ends up to largest diameter in the middle.

[0090] The oblate spheroid (or colloquially, “football”) shape and profile gives advantageous results when the angle of abrasion is rotated towards normal to the longitudinal axis of the tubular underneath. An optimal angle of attack may be found for abrading the external surface of the tubular, where the oblate spheroid shape maximizes contact and abrasive efficiency in view of the local contour or diameter of the tubular immediately below swivel brush 262. It will be appreciated that as the angle of abrading attack approaches normal (90 degrees) to the longitudinal axis of the tubular, the more the coned edge of the oblate spheroid shape comes to bear on contours on the tubular, reducing the potential brush pressure of swivel brush 262 on contours that increase the local diameter of the tubular. Tilting structure on swivel brush assembly 260, as described in more detail below, with reference to FIGS. 12A through 12E, further mitigates against damage to the tubular from swivel brush 262 contacting the external surface of the tubular too hard (especially during tubular contour changes that increase the tubular’s local diameter). Tilting springs 264 (which are part of the tilting structure described in more detail with reference to FIGS. 12A through 12E) may be seen on FIG. 6, although partially hidden from view. Likewise swivel brush motor 263 (for power rotating swivel brush 262) may also be seen on FIG. 6, although again

partially hidden from view. As noted above with reference to FIG. 5, swivel brush motor 263 may be any conventional power apparatus (such as a hydraulic, electric or pneumatic motor) to power-rotate swivel brush 262 at user-selected speeds on user-selected speed cycles.

[0091] It is useful to highlight some of the advantages provided by the ability of swivel brush assembly 260 and fixed brush train 240 to adapt to local variations in contour and diameter of the tubular beneath, as described above with reference to FIGS. 5 and 6. Without such ability to adapt to local variations in contour and diameter, “forcing” a rotating tubular under swivel brushes or fixed brushes may place undesirable local stress on, for example, the tubular, the ODS assembly, the structure for rotating the tubular, and the structure for supporting the tubular while it rotates. Over time, such undesirable stress may cause failures, or at least premature wear and tear on the tubular and/or the surrounding ODS and related structure. The ability of swivel brush assembly 260 and fixed brush train 240 to adapt to local variations in contour and diameter of the tubular thus mitigates against such stresses, wear and tear, and/or failures.

[0092] A further advantage provided by the ability of swivel brush assembly 260 and fixed brush train 240 to adapt to local variations in contour and diameter of the tubular is that, in combination with the ability to power-rotate swivel brush 262 and fixed brushes 242 in either direction, substantial improvements in the operational life of brushes become available. The ability of swivel brush assembly 260 and fixed brush train 240 to adapt to local variations assists in keeping swivel brush 262 and fixed brushes 242 at (or near) optimal brush pressure on the external surface of the tubular, avoiding premature brush wear by “crushing” the brushes and wear surfaces together. Further, the ability to periodically reverse the direction of rotation of swivel brush 262 and fixed brushes 242 during brushing operations (as may be required in ODS cleaning operation cycles anyway) further serves to enhance brush life by distributing brush wear more evenly.

[0093] FIG. 6 also illustrates exemplary propulsion structure for ODS assembly 220. It will be appreciated that ODS assembly may be propelled back and forth above the external surface of a stationary but rotating tubular by any conventional method and/or structure. The propulsion structure illustrated on FIG. 6 (and elsewhere in FIGS. 5 through 13B) is by way of example only. FIG. 6 illustrates ODS propulsion motors 291 deployed either side of ODS assembly 220. Propulsion motors 291 may be any conventional power apparatus (such as hydraulic, electric or pneumatic motors). Propulsion motors 291 rotate roller pinions 292, which in turn are engaged on geared tracks 293. Note that on FIG. 6, geared tracks 293 may only be seen in section. However, with momentary reference to FIG. 10, geared tracks 293 may be seen in isometric view from above. FIG. 10 also illustrates propulsion motors 291, although roller pinions 292 are hidden from view on FIG. 10. It will be further appreciated from FIGS. 6 and 10 that in the embodiments of ODS assembly 220 illustrated and described, an example of four (4) propulsion motors 291 propel ODS assembly 220 up and back along two (2) geared tracks 293. This disclosure is not limited in this regard, however, and other embodiments may deploy other numbers of propulsion motors 291 in various configurations on various numbers of geared tracks 293, per user design. Although not illustrated in detail on FIGS. 6 and 10, it will be understood that the travel of ODS assembly 220 is further kept in a straight line parallel to the longitudinal axis of a

tubular beneath by bearings and related conventional structure rolling on and between guide rails.

[0094] It will be also understood from FIGS. 6 and 10 that the operation of propulsion motors 291 may be controlled closely to allow a high level of corresponding control over the movement (and speed thereof) of ODS assembly 220 above a rotating tubular. Movement may be directed at any time, per user control, in a forward or backward direction at user-selected speeds. Such control over movement of ODS assembly 220 (and corresponding control over ODS operations) may be combined with control over concurrent internal tubular (MLI) operations and over rotation of the tubular to give a highly controlled cleaning, inspection and/or data analysis of the tubular at an enterprise level.

[0095] Reference is now made to FIGS. 7, 8 and 9 together. FIGS. 7, 8 and 9 illustrate substantially the same structure from different views. FIG. 7 is an elevation view. FIGS. 8 and 9 are isometric views from different angles.

[0096] FIGS. 7, 8 and 9 depict ODS assembly 220 in substantially identical form to ODS assembly 220 as depicted on FIG. 5 (including ODS laser 222, fluid jet assembly 280, swivel brush assembly 260, fixed brush train 240 and top shroud 250), except that on FIGS. 7, 8 and 9 also depict rotating tubular W beneath ODS assembly 220 and on which ODS assembly is operating. Tubular W includes at least one joint J. FIGS. 7, 8 and 9 further depict fixed lasers 224 beneath tubular W, whose fields of view scan the underside of tubular W as it rotates. It will be understood that fixed lasers 224 are stationary in user-selected fixed locations. Information gained from scans of fixed lasers 224 is advantageously combined with laser and optical camera information from ODS laser 222 as it moves back and forth above tubular W and coincides with (co-locates with) individual fixed lasers 224. The processing and use of laser and optical camera information is discussed in greater detail below.

[0097] All the disclosure above describing aspects and features of ODS 220 with reference to FIGS. 5 and 6 applies equally to ODS 220 as depicted on FIGS. 7, 8 and 9. With particular reference to swivel brush assembly 260, it will be seen on FIGS. 8 and 9 that swivel brush assembly 260 has been rotated about vertical swivel brush assembly axis 261 (shown on FIGS. 7 and 8) so that the plane of rotation of swivel brush 262 is at an angle to the longitudinal axis of tubular W. Referring back to disclosure associated with FIGS. 5 and 6, such rotation allows swivel brush 262 to take up a user-selected angle of attack when abrading the external surface of rotating tubular W, to account for features such as, for example, surface defects, helical wear patterns or discontinuities in diameter (such as at pipe joints J, described in more detail immediately below) on tubular W.

[0098] Pipe joints J illustrated on FIGS. 7, 8 and 9 illustrate examples of the variations in local contour and diameter that ODS assembly 220 may encounter during its travel back and forth while operating on the external surface of tubular W. Other changes in contour may be caused by, for example (and without limitation), bow or sag in tubular W, local out-of-roundness in the diameter of tubular W, or excessive wear, scarring or pitting at local points. As noted in earlier disclosure with reference to FIGS. 5 and 6, ODS assembly 220 is disposed to account for such local variations in contour and diameter of tubular W via articulated brush joints 244 and shock absorbers 248 on fixed brush train 240 (described in more detail below with reference to FIG. 11), and via tilting

springs **264** and related structure on swivel brush assembly **260** (described in more detail below with reference to FIGS. **12A** through **12E**).

**[0099]** Propulsion features and aspects illustrated on FIG. **10** (including propulsion motors **291** and geared tracks **293**) have already been described in association with earlier disclosure making reference to FIG. **6**. Other features and aspects of ODS assembly **220** illustrated on FIG. **10** are substantially as also described above with reference to FIGS. **5** through **9**. Features illustrated on FIG. **10** that are also illustrated on FIGS. **5** through **9**, carry the same numeral throughout.

**[0100]** FIG. **11** illustrates additional features of fixed brush train **240** from FIGS. **5** through **10**, with some enlargement and in isolation, and with top shroud **250** removed. All earlier disclosure regarding fixed brush train **240** with reference to FIGS. **5** through **10** applies equally to FIG. **11**. It will be recalled from such earlier disclosure that the concatenation of articulated brush joints **244** forms an articulated drive shaft for fixed brushes **242** driven by fixed brush motors **246** at either or both ends thereof. The articulated nature of the connections between fixed brushes **242** allows for semi-independent vertical movement of individual fixed brushes **242** while still permitting fixed brush motors **246** to rotate all fixed brushes **242** in unison. It will be further recalled that shock absorbers **248** further regulate the semi-independent vertical movement of individual fixed brushes **242** to enable fixed brushes **242** to maintain contact with the external surface of a tubular below despite local variations in tubular contour or tubular diameter.

**[0101]** FIG. **11** further illustrates fixed brush train lifts **243** for setting fixed brush train **240** at a general height above a tubular, according to user-selection. Fixed brush train lifts **243** may be any conventional lifting mechanism, such as a hydraulically-actuated cylinder, as illustrated on FIG. **11**. It will be appreciated that fixed brush train lifts **243** may be actuated to set a desired elevation for fixed brushes **242** with respect, for example, to a desired amount of brush pressure on a tubular having a nominal diameter. Fixed brush train lifts **243** actuate against fixed brush train lift springs **245** in order to provide spring resistance to the actuation of train lifts **243**. This spring resistance assists with smooth and precise actuation, which in turn assists with smooth and precise application of brush force by fixed brushes **242** on an expected nominal diameter tubular. As noted above, variations in local contour or diameter of the tubular may then be accounted for by semi-independent vertical movement of individual fixed brushes **242** provided by articulated joints **244** and shock absorbers **248**.

**[0102]** It will be further appreciated from FIG. **11** that fixed brush lifts **243** are not limited to setting an elevation for fixed brushes **242** that is parallel to the longitudinal axis of the tubular. Angles for fixed brush train **240** may be set such that fixed brushes **242** may apply greater pressure to the tubular at one end rather than the other. It will also be understood that this disclosure is not limited to deploying three (3) fixed brush train lifts **243** on one installation, as illustrated on FIG. **11**. The example of FIG. **11** is suitable for the exemplary fixed brush train **240** embodiment also illustrated on FIG. **11** with five (5) fixed brushes **242**. Other embodiments of fixed brush train **240** may deploy more or fewer than two (3) fixed brush train lifts **243**, and this disclosure is not limited in this regard.

**[0103]** FIGS. **12A** through **12E** should be viewed together. FIGS. **12A** through **12E** illustrate additional features of

swivel brush assembly **260** from FIGS. **5** through **10**, with some enlargement and in isolation, and with top shroud **250** removed. FIG. **12B** is an elevation view of swivel brush assembly **220** as shown on FIG. **12A**. FIG. **12C** is a cutaway view of swivel brush assembly **220** also as shown on FIG. **12A**. All earlier disclosure regarding swivel brush assembly **260** with reference to FIGS. **5** through **10** applies equally to FIGS. **12A** through **12E**. It will be recalled from such earlier disclosure (in particular with reference to FIGS. **5** and **6**) that swivel brush **262** may be set to rotate and abrade at an angle to the longitudinal axis of a tubular beneath, per user selection via rotation of swivel brush assembly **262** about vertical swivel brush axis **261**. It will also be recalled from earlier disclosure that illustrated embodiments of swivel brush assembly **260** deploy swivel brush **262** with an oblate spheroid (colloquially, “football”) shape and profile for advantageous performance over variations in the tubular’s local contour and diameter.

**[0104]** Earlier disclosure also described a “tilt” (or pivot) feature on swivel brush assembly **260** to assist swivel brush **262** in maintaining brush pressure while following the local contour of a rotating tubular beneath. FIGS. **12A** through **12E** describe the tilting feature in more detail. Referring to FIGS. **12A** through **12E**, tilting is about swivel brush assembly tilting axis **265** on FIG. **12A**, also represented by pivot **266** on FIGS. **12B** and **12C**. Such tilting will thus be seen to be about a substantially horizontal axis. Tilting is regulated by tilting springs **264**, seen on FIG. **12B** to hold swivel brush **262** (and connected structure) in spring equilibrium about pivot **266**. In this way, once the general height of swivel brush assembly **260** above a tubular is set, tilting springs **264** allow swivel brush **262** to tilt about pivot **266** as it encounters local variations in the contour or diameter of the tubular beneath. During such tilting, responsive to compression pressure from tilting springs **264**, swivel brush **262** may still maintain a substantially constant contact on the surface of the tubular.

**[0105]** FIGS. **12A** through **12E** further illustrate swivel brush assembly lift **267** for setting swivel brush assembly **260** at a general height above a tubular, according to user-selection. Swivel brush assembly lift **267** may be any conventional lifting mechanism, such as a hydraulically-actuated cylinder, as illustrated on FIGS. **12A** through **12B**. It will be appreciated that swivel brush assembly lift **267** may be actuated to set a desired elevation for swivel brush **262** with respect, for example, to a desired amount of brush pressure on a tubular with nominal diameter below. As shown best on FIG. **12C**, swivel brush assembly lift **267** actuates against swivel brush assembly lift spring **268** in order to provide spring resistance to the actuation of swivel brush assembly lift **267**. This spring resistance assists with smooth and precise actuation, which in turn assists with smooth and precise application of brush force by swivel brushes **262** on an expected nominal diameter tubular. As noted above, variations in local contour or diameter of the tubular may then be accounted for by tilting springs **264** holding swivel brush **262** in spring equilibrium about pivot **266**.

**[0106]** FIGS. **12A** through **12E** further illustrate structure to enable controlled rotation of swivel brush **262** about vertical swivel brush axis **261**, further to more general disclosure above regarding such rotation. Swivel rotation motor **269** on FIGS. **12A** through **12E** operates swivel rotation gears **270** to rotate swivel brush **262** about axis **261**. Swivel rotation motor **269** may be any conventional power apparatus (such as a



hydraulic, electric or pneumatic motor) to power-rotate swivel brush 262 about axis 261 per user control.

[0107] FIGS. 12D and 12E illustrate, in stroboscope or “freeze-frame” style, the various motions available to swivel brush assembly 260 during normal operation. FIGS. 12D and 12E illustrate (with further reference to FIGS. 12A through 12C): (1) actuation of swivel brush assembly lift 267 to set a general height for swivel brush 262, (2) rotation of swivel brush 262 about vertical swivel axis 261, and (3) tilting of swivel brush 262 about pivot 266.

[0108] FIGS. 13A and 13B should be viewed together. FIGS. 13A and 13B illustrate additional features of fluid jet assembly 280 from FIGS. 5 through 10, with some enlargement and in isolation, and with top shroud 250 removed. FIG. 13B is an elevation view of fluid jet assembly 280 as shown on FIG. 13A. All earlier disclosure regarding fluid jet assembly 280 with reference to FIGS. 5 through 10 applies equally to FIGS. 13A and 13B. It will be recalled from such earlier disclosure (in particular with reference to FIG. 5) that fluid jet assembly 280 provides jets 282, which spray or blast fluids (in gaseous or liquid state) onto the external surface of a rotating tubular beneath. Individual jets 282 are user-selectable according to operational needs.

[0109] FIGS. 13A and 13B further illustrate fluid jet assembly lift 286 for setting fluid jet assembly 280 at a general user-desired height above a tubular. Electronic control systems then, on the fly, make small changes in the elevation of jets 282 above the external surface of the tubular by actuating jet height control cylinders 284. In this way, a user-selected distance between jets 282 and the external surface of the tubular may be maintained, notwithstanding local variations in contour or diameter of the tubular that jets 282 may encounter during their travel along the length of the tubular.

[0110] FIGS. 14 through 19G illustrate ODS buggy 320, which is an alternative embodiment to the buggy aspects of ODS assemblies previously disclosed herein, including ODS assembly 201 described generally above with reference to FIG. 1, and ODS assembly 220 described generally above with reference to FIG. 5. FIG. 14 is an isometric view of ODS buggy 320. It will be appreciated ODS 320 includes many of the buggy aspects disclosed earlier with respect to ODS assembly 220 (see FIG. 5). Variations and improvements of ODS buggy 320 over corresponding or prior-generation features of ODS assembly 220 are described below with reference to FIGS. 14 to 19G. The disclosure of ODS buggy 320 below with reference to FIGS. 14 to 19G should be read in conjunction with the disclosure above of ODS assembly 220 with reference to FIGS. 5 through 13B. Where not inconsistent, features of ODS buggy 320 that are not disclosed below with reference to FIGS. 14 to 19G are incorporated into buggy 320 from corresponding, or functionally equivalent, features of ODS assembly 220 disclosed on, and with reference to, FIGS. 5 through 13B.

[0111] It will be appreciated with reference to FIGS. 14 through 19G that ODS buggy is illustrated with many of its conventional operational features omitted for clarity. For example, covers and parts of housings are omitted to assist in illustration of the internal features of various assemblies and mechanisms. Similarly, other conventional items and features such as hydraulics, electrical apparatus, supply hoses, safety guards, etc., etc., are omitted on FIGS. 14 through 19 for clarity.

[0112] FIG. 14 illustrates ODS buggy 320 with four (4) separate tool assemblies: camera assembly 390, fluid jet

assembly 380, brush train 340 and swivel brush assembly 360. Each tool assembly is deployed in its own tool “chamber”. Each tool assembly operates (and is controlled) within its own chamber, separately and independently from the other tool assemblies, and each tool assembly’s elevation is adjustable within the chamber independently from the elevation of other tool assemblies in other chambers. It will be appreciated that the embodiment of ODS buggy 320 disclosed on FIGS. 14 through 19G provides an exemplary number of four (4) tool “chambers” in an arrangement as illustrated. For the avoidance of doubt, it will be appreciated that these chambers in their relative arrangement are exemplary only, and nothing in this disclosure should be construed to limit ODS buggy 320 to any number of chambers, to the chambers containing any type of tools or equipment, or to the tools or equipment in the chambers being in any sequence.

[0113] As noted above with reference to FIGS. 5-10, the disclosed ODS laser 222 generates samples from which surface contour data may be mapped regarding the tubular. As further noted above, one of the uses to which the DAS puts this surface contour data is to regulate, independently and in real time “on the fly”, the height of each of the tool chambers on ODS buggy 320 above the external surface of the tubular as the tools or equipment in each chamber operate on the tubular’s surface. In this way, as the laser recognizes substantial changes in the tubular’s contour (such as, for example, at a pipe joint), the DAS regulates the height of the tools or equipment in each chamber to an optimum preselected height above tubular’s external surface as the contour change in the tubular passes beneath.

[0114] Viewing the orientation of ODS buggy 320 as depicted on FIG. 14, the right-hand end may be considered a “leading” end, and the left-hand end a “trailing” end. This means that if ODS buggy 320 is considered on FIG. 14 to be depicted in a “rest” position just before commencing work on a tubular, the right-hand “leading” end will lead movement of the buggy and encounter the tubular first, and the left-hand “trailing end” will bring up the rear.

[0115] In such an orientation, it will be seen from FIG. 14 that brush train 340 on ODS buggy 320 immediately follows fluid jet assembly 380, and that swivel brush assembly 360 follows brush train 340. By comparison with ODS assembly 220 on FIG. 5, swivel brush assembly 360 and brush train 340 on ODS buggy 320 have switched positions. Similarly, it will be seen from FIG. 14 that camera assembly 390 on ODS buggy 320 now immediately leads fluid jet assembly 380. By comparison with ODS assembly 220 on FIG. 5, ODS assembly 220 does not have a separately disclosed camera assembly.

[0116] The advantage sought in switching the respective positions of swivel brush assembly 360 and brush train 340 on ODS buggy 320 (as opposed to their corresponding relative position on ODS assembly 220) is related to cleaning operations when ODS buggy 320 is brought back over a tubular in “reverse”, i.e. swivel brush assembly 360 leads the movement of ODS buggy 320. In such reverse operations, it is advantageous to rinse off the tubular after cleaning operations in the “forward” direction. This rinsing operation is facilitated by having swivel brush assembly 360 lead brush train 340 (as happens when ODS buggy 320 travels in “reverse”). Brushing residue is likely to be left on the tubular after cleaning operations in the “forward” direction (in which the brushing operations bring up the rear). When ODS buggy 320 is placed in “reverse”, a light brushing operation may be prescribed,



followed by a low pressure rinse provided by fluid jet assembly 380 (bringing up the rear when ODS buggy 320 is in “reverse”). This rinse assists removal of brushing residue from the tubular.

[0117] It will be further appreciated by comparison between FIG. 5 and FIG. 14 (and other views of ODS 320) that ODS 320 is not illustrated with a laser assembly. Refer and compare to disclosure above associated with FIG. 5 for discussion of ODS laser 222 on ODS assembly 220. It will be understood that ODS buggy 320 provides a laser assembly, which has been omitted on FIG. 14 (and subsequent Figures) for clarity. The discussion throughout this disclosure of ODS laser 222 and its functions and capabilities (including, without limitation, all the disclosure herein regarding acquisition of contouring data) apply equally to ODS buggy 320. The primary difference is that ODS laser 222 on ODS 220 on FIG. 5 was described above as a combination laser and optical camera. On ODS buggy 320 illustrated on FIG. 14 (and subsequent Figures), optical camera is deployed in its own separate, independently controllable tool “chamber”. See camera assembly 390 on FIG. 14.

[0118] As noted above, ODS buggy 320 on FIG. 14 provides camera assembly 390, fluid jet assembly 380, brush train 340 and swivel brush assembly 360 each in its own separate, independently-controllable tool “chamber”. One independently-controllable feature in each tool chamber is the elevation that tools in the chamber may be set above the tubular below. It will be seen on FIG. 14 that each tool chamber provides its own elevation plate whose specific elevation is controlled by extension and retraction of corresponding elevation plate pistons. In more detail on FIG. 14, the elevation of camera elevation plate 391 is set by actuation of camera elevation pistons 392, the elevation of fluid jet elevation plate 381 is set by actuation of fluid jet elevation pistons 382, the elevation of brush train elevation plate 341 is set by actuation of brush train elevation pistons 342, and the elevation of swivel brush elevation plate 361 is set by actuation of swivel brush elevation pistons 362.

[0119] Independent control over the elevation of each tool chamber’s tools above the tubular facilitates precise cleaning and inspection operations, as well as other advantages. Actuation of camera elevation pistons 392 allows precise control over focal distance between the optical cameras on camera assembly 390 and the external surface of the tubular below. Actuation of fluid jet elevation pistons 382 allows precise control over spraying distance between the fluid nozzles on fluid jet assembly 380 and the external surface of the tubular below. Actuation of brush train elevation pistons 342 allows precise control over contact pressure of the brushes in brush train 340 on the external surface of the tubular below. Actuation of swivel brush elevation pistons 362 allows precise control over contact pressure between the swivel brush on swivel brush assembly 360 and the external surface of the tubular below.

[0120] Further, as described above in detail with reference to FIG. 5 for ODS assembly 220, and below in detail with reference to the disclosed Data Acquisition System (“DAS”), the independent control of the elevation of tools in tool chambers on ODS buggy 320 may also be responsive in real time to “contour data” and other data acquired regarding the external surface and diameter of the tubular. As described in such other disclosure, the laser assembly and/or the optical camera are configured, in preferred embodiments, to acquire, process

and generate such “contour data” and other data regarding the external surface and diameter of the tubular.

[0121] With further reference to FIG. 14, therefore, it will be appreciated that, responsive to contour data and related data acquired in real time as ODS buggy 320 travels along the tubular, adjustments to the elevations of camera assembly 390, fluid jet assembly 380, brush train 340 and swivel jet assembly 360 may be made on the fly to suit changes in contour or diameter in the tubular as they arise and are detected. Such adjustments may be made, responsive to contour data and related data, by extending or retracting pistons in each tool chamber independently as required.

[0122] FIGS. 15A through 15D are elevation views of ODS buggy 320 as shown on FIGS. 14 and 15A. As described earlier, FIG. 15A depicts the “trailing” end of ODS buggy 320, in which swivel brush assembly 360 is in the foreground, with brush train assembly 340 (partially hidden) immediately behind swivel brush assembly 360, and portions of camera assembly 390 visible behind brush train assembly 340. FIG. 15B depicts the “leading” end of ODS buggy 320, in which camera assembly 390 is in the foreground, with brush train 340 visible behind camera assembly 390, and portions of swivel brush assembly 360 visible further behind brush train assembly 340. Note that fluid jet assembly 380 is substantially hidden from view in FIGS. 15A and 15B.

[0123] FIGS. 15C and 15D illustrate the “front” and “back” of ODS buggy 320, respectively, as viewed from the orientation of FIG. 14. FIGS. 15C and 15D show camera assembly 390, fluid jet assembly 380, brush train 340 and swivel jet assembly 360 in their respective tool chambers. FIGS. 15C and 15D also point out the following features (to be discussed in greater detail below with reference to additional figures): (1) cameras 393 and lights 394 on camera assembly 390; (2) lower and upper brush train springs 344L and 344U, and brush wheels 343 on brush train 340; (3) camera elevation plate 391 and camera elevation pistons 392; (4) fluid jet elevation plate 381 and fluid jet elevation pistons 382; (5) brush train elevation plate 341 and brush train elevation pistons 342; and (6) swivel brush elevation plate 361, and swivel brush elevation pistons 362.

[0124] FIGS. 16A through 16E describe brush train 240 in greater detail. FIG. 16A isolates brush train 340 from the elevation view of FIG. 15C, and shows the same parts and features as FIG. 15C. It will be understood from FIG. 16A that brush wheels 343 are each suspended independently from brush train elevation plate 341 by upper and lower brush train springs 344U and 344L. Although not visible on FIG. 16A, there is a small gap between neighboring brush wheels 343, indicated on FIG. 16A (and subsequent Figures) by gaps G. In preferred embodiments gaps G are about 1/16" wide, although brush train 340 is not limited in this regard.

[0125] FIG. 16B is an isometric view of the section shown on FIG. 16A. The section of FIG. 16B is taken at one of the gaps G. In addition to structure already described with respect to previous FIGURES, FIG. 16B shows brush train drive shaft 345. As will be described with reference to other Figures, a single brush train drive shaft 345 drives all brush wheels 343 via drive belts (such drive belts hidden from view on FIG. 16B). This drive belt linkage permits brush wheels 343 to be rotationally independent from one another, and all independently suspended from brush train elevation plate 341 by upper and lower brush train springs 344U and 344L. The independently-suspended nature of each of brush wheels 343 allows each brush wheel 343, upon contact with a rotating

tubular below, to self-adjust its own elevation by small amounts in response to small changes in the profile, diameter or contour of the tubular, all without affecting the elevation of other brush wheels 343. This ability to make of brush wheels to make small, independent elevation changes is in addition to any elevation adjustments made to the entire brush train 340 by raising or lowering brush train elevation plate 341 in response to contour data and other information from the DAS (refer to disclosure associated with FIG. 14 above). The combination of (1) small changes to brush wheel 343 elevation via independent suspension, (2) changes in elevation of the entire brush train 340 via adjustment of brush train elevation plate 341, and (3) the fact that brush wheels 343 are each suspended from two independently-acting brush train springs 344U and 344L, enables a precise contact pressure to be prescribed and maintained by brush wheels 343 on the external surface of a rotating tubular below. In preferred embodiments, this brush pressure is about 50 lbs of pressure, although this disclosure is not limited in this regard. The prescribed precise brush pressure may be maintained despite changes encountered in the profile, contour or diameter of the tubular as brush train 340 moves over the tubular. This precise brush pressure in turn allows a more effective clean, and prolongs the life of brush wheels 343.

[0126] With further reference to FIG. 16B, the positioning of brush train drive shaft 345 away from the individual brush wheels 343 also makes brush train 340 easier to maintain. When brush wheels 343 require replacement, they may be removed independently from brush train 340 (as opposed to, for example, threading them off a common axle shared with other brush wheels).

[0127] FIGS. 16C, 16D and 16E illustrate aspects of brush train 340 close-up in isolation, in which FIGS. 16C and 16D are isolated from FIGS. 15C and 15D respectively, and FIG. 16E is an isometric view as shown generally on FIG. 16D. In addition to features and parts of brush train 340 already described, FIGS. 16C, 16D and 16E show brush train motor 346, brush train drive belt 347, and brush wheel drive belts 348. FIGS. 16C, 16D and 16E and the drive linkage illustrated thereon are self-explanatory, consistent with disclosure above.

[0128] FIGS. 17A, 17B and 17C are isolated views of swivel brush assembly 360, in which FIGS. 17A and 17B are isolated from FIGS. 15C and 15A respectively, and FIG. 17C is an isometric view of FIG. 17A. FIGS. 17A, 17B and 17C, in combination, illustrate swivel brush elevation plate 361, swivel brush elevation piston 362, swivel brush motor 363, tilting springs 364, swivel brush 365, pivot 366, swivel brush rotation motor 367 and swivel rotation gears 368. By comparison to the disclosure above of swivel brush assembly 260 on ODS assembly, with reference to FIGS. 6, 12A, 12B and 12C, it will be appreciated that swivel brush assembly 360 on ODS buggy 320 is structurally and functionally similar to swivel brush assembly 260 on ODS assembly 220. The disclosure above regarding swivel brush assembly 260 on ODS assembly 220 is incorporated herein and applied to swivel brush assembly 360 on ODS buggy 320, where not inconsistent. One difference has been described above with reference to FIG. 14, in that adjustments to the elevation of swivel brush assembly 360 on ODS buggy 320 are made via extension and retraction of swivel brush elevation pistons 362 acting on swivel brush elevation plate 361. As also noted above with reference to FIG. 14, in preferred embodiments, such elevation adjustments of swivel brush assembly 360 are made

responsive to profile, contour, diameter and other data regarding the external surface of the tubular on which swivel brush assembly 360 is acting, as measured by the DAS.

[0129] FIGS. 18A and 18B are isolated views of fluid jet assembly 380, in which FIGS. 18A and 18B are isolated from FIGS. 15C and 15B respectively. FIG. 18C is an isometric view of the section shown on FIG. 18A. FIGS. 18D and 18E show aspects of fluid jet assembly 380 close-up in isolation, in which FIG. 18D is an enlargement of the isometric view of FIG. 18C, and FIG. 18E is an isometric view shown generally on FIG. 18D.

[0130] FIG. 18A through 18E, in combination, illustrate fluid jet elevation plate 381, fluid jet pistons 382, fluid jet manifold 383, fluid inlet 384, fluid jet bracket 385, fluid jet piston bracket 386, fluid jet screw drive 387, fluid jet openings 388 and fluid jet pivot 389. The operation of fluid jet assembly 380, as illustrated, is to deliver selected cleaning (and other) fluids from a prescribed distance and angle onto the external surface of a tubular below as the tubular rotates. It will be appreciated that fluid jet manifold 383 is made of suitable conventional corrosion-resistant material, such as stainless steel, and provides fluid inlet 384 to receive fluids selectively delivered by conventional apparatus. Fluids pass within fluid jet manifold 383 from fluid inlet 384 through to exit via fluid jet openings 388. Fluid jet openings 388 are shaped to encourage a conical-shaped delivery of fluids, in order to maximize coverage on the external surface of a tubular below. As shown on FIG. 18E, fluid jet openings 388 are also advantageously in offset formation, in order to minimize interference between the conical-shaped delivery from each fluid jet opening 388. Preferred embodiments of fluid jet manifold 383 provide eight (8) fluid jet openings 388 of about 1/2" diameter in fluid jet manifold 383, although this disclosure is not limited in these regards.

[0131] It will be further seen from FIG. 18B, for example, that fluid jet manifold 383 is anchored to the underside of fluid jet elevation plate 381 via fluid jet bracket 385. Fluid jet manifold 383 is positioned to be above the centerline of a tubular beneath, with its pattern of fluid openings oriented longitudinally with respect to such a tubular. It will be seen from FIGS. 18D and 18E, for example, that fluid jet 383 manifold is further attached to fluid jet bracket 385 so that it may tilt about fluid jet pivot 389. In this way, fluid jet openings 388 may dispense fluid laterally across a tubular rotating underneath as ODS buggy 320 travels along the length of the tubular.

[0132] FIGS. 18B through 18E show fluid jet screw drive 387 interposed between fluid jet manifold 383 and fluid jet screw bracket 386. Fluid jet screw bracket 386 is also anchored to the underside of fluid jet elevation plate 381. In preferred embodiments, fluid jet screw drive 387 is electrically actuated (as opposed to a hydraulically actuated piston, for example), although this disclosure is not limited in these regards. It will be understood that by actuation of fluid jet screw drive 387, fluid jet manifold 383 may be tilted back and forth about fluid jet pivot 389. Fluid jet manifold 383 may thus dispense fluids laterally across a tubular on-the-fly according to selectable control of fluid jet screw drive 387. In preferred embodiments, fluid jet screw drive 387 is configured to control fluid jet manifold 303 to dispense fluids in a sweep of about 30 degrees either side of vertical, although this disclosure is not limited in this regard.

[0133] It will be therefore appreciated that in combination with control over the height from which fluid jet manifold 383

dispenses fluid on-the-fly (via fluid jet elevation plate **381** adjusted by fluid jet elevation pistons **382** controlled by the DAS, per earlier disclosure), a user may also control the extent and speed of the lateral sweep of the fluid jets on-the-fly. This gives excellent control over fluid cleaning operations.

[0134] Although not illustrated on FIGS. **18A** through **18E**, alternative embodiments of fluid jet assembly may also provide structure to allow fluid jet manifold **383** to slide laterally in a controlled fashion. Other alternative embodiments may allow fluid jet assembly to rotate horizontally. Slotted or shaped bolt holes in the anchoring of fluid jet bracket **385** to fluid jet elevation plate **381** could enable such alternative embodiments. Alternatively, additional fluid jet drive screws (or hydraulic pistons), anchored to fluid jet elevation plate **381** and attached to fluid jet manifold **383** or fluid jet bracket **385** via conventional linkage, could also enable such alternative embodiments.

[0135] FIG. **19A** is an isolated view of camera assembly **390**, in which FIG. **19A** is isolated from FIG. **15C**. FIG. **19B** is an isometric view of the section shown on FIG. **19A**. FIGS. **19C** and **19D** show aspects of camera assembly in close-up isolation, in which FIG. **19C** is shown generally on FIG. **19B**, and in which FIG. **19D** is the same as FIG. **19C** except with sliding door **396** illustrated as open. FIG. **19E** is a plan view of FIG. **19D**. FIGS. **19F** and **19G** are further isometric views of aspects of camera assembly **390** in close-up isolation, in which FIG. **19F** is shown generally on FIG. **19E**, and FIG. **19G** is the same as FIG. **19F** except with containment cover **395** in place.

[0136] FIGS. **19A** through **19G** illustrate, in combination, camera elevation plate **391**, camera elevation pistons **392**, cameras **393**, lights **394**, containment cover **395**, sliding door **396**, door actuator **397**, and camera actuator holes **398**. Cameras **393** take samples, in the form of pictures of the external surface of a tubular, by shooting high-speed pictures through an opening in camera elevation plate **391**. Door actuator **397** operates on sliding door **396** over the opening in camera elevation plate **391**. It will be understood that cameras **393** and lights **394** may need to be protected during heavy cleaning operations. In such operations, door actuator **397** closes sliding door **396**. When camera sampling is to be done, door actuator **397** opens sliding door **396** to allow cameras **393** to “see” the rotating tubular below through the opening in camera elevation plate **391**.

[0137] It will be appreciated with reference to FIGS. **19A** through **19G** that support structure and actuation linkage for cameras **393** and lights **394** has been omitted for clarity. Cameras **393** are high speed optical cameras, per discussion above with reference to FIG. **5**, and below with reference to the DAS. Lights **394** provide a highly focused beam in the shape of a fan, advantageously overlapping the diameter of the tubular below. The function of cameras **393** is generally to take samples in the form of calibrated pictures of the tubular below, in order to measure the local diameter of the tubular at the tubular “slice” of the sample. This function is discussed in detail below in the sections disclosing aspects and features of the DAS.

[0138] Lights **394** on camera assembly **390** are provided to assist with precise picture taking by cameras **393**. In preferred embodiments, camera assembly **390** provides four (4) cameras and one set of lights, although this disclosure is not limited in these regards. Cameras **393** are user selectable to be independently active or “off” at any time. The embodiment of

camera assembly **390** illustrated on FIGS. **19A** through **19G** provides for small manual independent adjustment of cameras **393** and lights **394** via conventional actuators and linkage omitted for clarity. Such small adjustment includes tilting, pivoting, sliding, rotating, raising and lowering of cameras **393** and lights **394** to get the optimum exposure for the pictures taken by cameras **393**. Other embodiments not illustrated, may include mechanical, remote adjustment of cameras **393** and lights **394** for optimum picture exposure. It should be noted that operationally, cameras **393** and lights **394** are protected by containment cover **395**, as illustrated on FIG. **19G** (although also omitted for clarity on other Figures). As shown on FIG. **19G**, containment cover **395** provides actuator holes **398** for actuators and other linkage to access cameras **393** and lights **394**, in order to enable the small adjustments described immediately above. It will be appreciated that large adjustments of the distance between the cameras **393** and the tubular below is provided on-the-fly by camera pistons **392** raising and lowering camera elevation plate **391**, responsive to tubular contour, diameter and other data regarding the tubular acquired in real time by the DAS (as described above with reference to FIG. **14**).

[0139] Although not illustrated, the scope of this disclosure contemplates an embodiment with two independent sets of cameras sampling the same tubular “slice”. In such an embodiment, 3-D data regarding the tubular’s diameter at the “slice” could be acquired and processed.

[0140] The electronic control systems described above (for maintaining distance between jets **282** and external surface of tubular) utilize real time information regarding the tubular collected by ODS laser **222**. Referring back to earlier disclosure associated with FIGS. **5** through **9**, it will be recalled that as ODS assembly **220** travels back and forth above a rotating tubular, ODS laser **222** scans the external surface of the tubular. It will be further recalled that in currently preferred embodiments, ODS laser **222** includes both a laser and an optical camera to scan the external surface of the tubular. Laser scans by ODS laser **222** may identify contours and external surface anomalies on the tubular of all types in real time, including surface defects (such as, for example, scratches, gouges, divots, pitting, and laminations), as well as larger variations in tubular diameter such as pipe joints. Such laser scan data regarding the external surface of the tubular is also referred to in this disclosure as “contouring data” or “contour data”, and is derived from laser data but not optical camera data. As will be described in greater detail below, contour data derived solely from laser scans is used for operational cleaning purposes (including for adjusting the height of fluid jet assembly **280**, swivel brush assembly **260** and fixed brush train **240** above the tubular’s surface) as well as for inspection purposes. On the other hand, optical camera data is used in combination with laser data from ODS laser **222**, and further in combination with data from fixed lasers **224** beneath the tubular, in order to derive dimensional data regarding the outside diameter (“OD”) of the tubular for inspection purposes. The advantages of optical camera data, and the use thereof in deriving OD dimensional data, are also discussed in more detail below.

[0141] Returning now to further consideration of contour data derived from laser scans (only) by ODS laser **222**, it will be appreciated that substantial information regarding the contours of a tubular may be obtained. Given knowledge (1) of the absolute position of ODS laser **222** on a tubular at a particular moment in time, and (2) of the rotational speed of

the tubular at such moment in time, ODS laser 222 may “map” the contours over the entire external surface of the tubular. Knowledge of the absolute position of ODS laser 222 may be obtained via methods that include (1) knowing when ODS laser 222 first encounters the tubular as it begins its first pass over the tubular, and (2) establishing relative position to the “first encounter” from sensors, such as optical sensors, deployed in the propulsions system (such as in, or attached to, roller pinions 292 and/or geared tracks 293 as illustrated and described above with reference to FIGS. 6 and 10). It will be appreciated that such optical sensors may conventionally translate measured speed and direction of travel of ODS assembly 220 into a position relative to the “first encounter”.

[0142] Further consideration will now be given to data regarding the OD of the tubular derived for inspection purposes from both laser and optical camera data from ODS laser 222 (on FIGS. 5 through 10), in combination with laser data from fixed lasers 224 (on FIGS. 7 through 10). Such laser and optical camera data may be combined to obtain real time “caliper”-type measurements of the tubular at intervals along the tubular’s length. Combined and coordinated laser data and optical camera data from ODS laser 222 and fixed lasers 224 may enable dimensional irregularities or anomalies in the tubular (such as sag, wobble or bow in the tubular, or areas where the tubular is out-of-round) to be identified and location-tagged along the tubular’s length. This “caliper”-type data may be used in real time to correct (via adjustment and compensation): (1) overall dimensional data regarding the OD of the tubular and any point along its length, as well as (2) contour data obtained from laser data from ODS laser 222 as described in the immediately preceding paragraphs.

[0143] It is useful to highlight some of the aspects and advantages in combining optical camera data with laser data in obtaining information about the OD of the tubular, or “pipe” as used in the following optical camera discussion. Determining the outside diameter of a drill pipe optically is a challenge. As an object moves closer or farther from a fixed zoom lens, it grows and shrinks respectively. For measurement purposes on pipes of varying diameters and centerlines, simply taking a picture and determining the size of a pipe is not practical. However, the combined use of an optical lens with a range finding laser adds the axis of reference necessary to account for the varying centerline distances and calculation of diameters possible.

[0144] In order to achieve a pipe diameter measurement, an image is taken of the pipe using a line scan camera. The line scan camera captures a slice of the pipe. This slice contains a one dimensional array of information, essentially containing ‘material’ and ‘non-material’. The ‘material’ being pipe, the “non-material” representing anything outside the pipe. The differentiation between the two is made using threshold values on the grayscale information contained in the array. For instance, given a grayscale color spectrum of 8 values, non-material may be any value below 3, while material would show 4 through 8. With the combination of a light source and a filter on the lens, only the light reflecting off pipe material will be allowed into the camera. This will allow for a fine resolution between “material and “non-material” and for fast image processing and information output.

[0145] Now, a calculation of the number of “material” pixels in the array divided by (material+non-material) pixels will give the percentage material in any particular slice of information. Without a frame of reference, this number is useless. However, the combination of this percentage with a range

finding laser at each point a slice is taken allows for accurate calculation of length based on percentage of material.

[0146] As an example, if at 1 inch away from the lens, an image contains 50% material and the known size of the pixel array at 1 inch away is 1 inch, the object size may be calculated to be 0.5 inches. Taking this one step further, if at 10 inches away from the lens the pixel array is known to contain 10 inches of information, an image containing 5% material pixels will also be 0.5 inches. Now, using this concept in combination with a range finding laser and careful calibrations of the pixel array size to distance ratio, an image, or slice of a pipe, can be used to very accurately calculate diameter based on simply the data contained in a slice and the reference distance the lens is from the pipe, which is provided by the range finding laser.

[0147] Using a high scan rate and high resolution camera, very accurate calculations can be made as to the diameter of the pipe. Combining multiple line scan cameras will multiply the accuracy. This system will traverse the length of the pipe, taking slices of information quickly and accurately and allow for a novel way to determine pipe diameter information.

[0148] Returning now to consideration of contour data, it will thus be appreciated that contour data regarding the tubular acquired by laser scans by ODS laser 222 (and preferably corrected with “caliper”-type data) may then be fed in real time to control systems on other operating systems on ODS assembly 220. Such real time contour data may then be used to make corresponding adjustments to the operating systems. For example, and without limitation; such real time contour data may be used to make corresponding adjustments that include: (1) adjusting the distance between jets 282 and the external surface of the tubular in order to maintain a constant distance therebetween; (2) adjusting the angle of attack of swivel brush 262 in order to obtain optimum abrasion; (3) adjusting the general elevation of swivel brush assembly 260 or fixed brush train 240 in order to accommodate a large tubular diameter change such as a pipe joint; (4) adjusting the speed or direction of rotation of swivel brush 262 or fixed brushes 242 according to upcoming conditions; or (5) adjusting the speed or direction of travel of ODS assembly 220 according to upcoming conditions.

[0149] It is useful to highlight some of the advantages of maintaining a constant distance between jets 282 and the external surface of the tubular, notwithstanding local contour or diameter variations in the tubular. If jets 282 are too close to the tubular’s external surface, even momentarily, then damage to the tubular’s surface (such as steel erosion and cutting) may occur, especially during high pressure fluid blast cycles. Such damage occurs substantially immediately if the right conditions exist. On the other hand, if jets 282 are too far away, again even momentarily, then fluid jet assembly 280’s operations (such as cleaning, rinsing, coating, drying, etc.) may be less than fully effective, and possibly compromised. As distance between jets 282 and the tubular’s surface increases, operating effectiveness decreases exponentially.

[0150] It is therefore highly advantageous to maintain an optimal distance between jets 282 and the external surface of the tubular, so that the operating effectiveness of jets 282 is maximized without causing damage to the tubular’s surface. The electronic control system using data that includes real time contour data obtained by laser data from ODS laser 222, as described above, is useful to maintain that optimal distance.

**[0151]** It will be further appreciated that the ODS contour data acquisition and processing system, and related electronic control systems, described in the preceding paragraphs, may also be combined and coordinated in real time with concurrent data regarding the internal surface and diameter of the tubular. Exemplary internal data acquisition structure and technology is described in U.S. Provisional Application Ser. No. 61/707,780 (to which provisional application this application claims priority) and commonly-assigned, co-pending U.S. patent application Ser. No. 13/832,340 with reference to a Multi-Lance Injector (“MLI”) system for internal inspection and cleaning of tubulars. Such concurrent internal data may supplement ODS contour data to provide additional information regarding the tubular in real time, including, for example, tubular wall thickness information and further analysis of points of interest such as apparent cracks, etc.

**[0152]** It may be advantageous in ODS operations to acquire ODS contour data in a first pass over the tubular, and then return (or go back on a second pass) for more information. Further data regarding the OD of the tubular may be gathered in order to prepare a summary thereof. Additionally further investigation may be conducted on points of interest (such as cracks, pitting, gouges, etc.) identified and location-tagged on a previous pass. Second- (or subsequent-) pass investigations may call for the ODS to pass by points of interest more slowly, or at a different tubular rotation speed, than might be optimal for cleaning operations on an previous pass.

**[0153]** Further advantages may also be gained by combining and coordinating data acquisition from both the internal and external surfaces of the tubular. The following disclosure discusses such combined and coordinated data acquisition regarding wall thickness measurements of tubulars.

**[0154]** Conventional systems are known in which the thickness of a pipe wall is interrogated by ultrasonic methods. In such systems, an ultrasonic transducer is deployed on (or near) the external surface of the pipe, and the ultrasonic echoes received back are analyzed for wall thickness information. It is known to take such measurements while the pipe rotates about its cylindrical axis. Significantly, during such measurements, the transducer is required to be in good ultrasonic contact with the external surface of the pipe, and thus there has to be a constant layer of fluid (such as water) connecting the transducer to the external surface of the pipe as it rotates. The pipe also has to be marked with a circumferential reference in order to associate ultrasonic measurements with wall thickness locations. Conventionally such marking is done by visibly marking a longitudinal line down the external surface of the pipe. The line can then be read by a photo electric cell as the line passes its field of view during rotation of the pipe.

**[0155]** The measurement of tubular wall thickness in the Scorpion System is in sharp contrast to conventional systems. In preferred embodiments, although other conventional wall thickness measurement protocols may be used, measurement of wall thickness is preferably by magnetic flux density analysis from the inside of the tubular to the outside. This protocol is in distinction to ultrasonic echo analysis from the outside only. The Scorpion System deploys a probe generating a predetermined magnetic field on the end of an MLI lance. The probe moves up and down the inside of the tubular as the tubular rotates. Such a probe may be deployed, for example, on tool heads disclosed in commonly-assigned, co-pending U.S. patent application Ser. No. 13/832,340. One or more

magnetic flux sensors are deployed on the outside of the tubular, and may also be moveable up and down the outside of the tubular as the tubular rotates. Advantageously, some or all of the magnetic flux sensors may be deployed on ODS buggy (embodiments of which are disclosed herein). The magnetic flux sensors generate samples of measured magnetic flux density at known points on the external surface of the tubular as the tubular rotates. The samples thus collectively form a helix of samples at corresponding known points on the external surface of the tubular.

**[0156]** As noted, a probe generates a predetermined magnetic field on the inside of the tubular. Each magnetic flux density sample taken on the outside allows the degradation of the magnetic field through the wall of the tubular to be calculated at each sample’s corresponding location on the tubular. This allows the degradation to be mapped over the tubular. When calibrated, variations in the nature and the amount of the degradation of the field from sample to sample will be understood to correspond to variations in both the density and the thickness of the tubular’s wall from point to point on the tubular’s surface where the samples were taken. Thus variations in both the density and thickness of the tubular’s wall may be mapped over the tubular.

**[0157]** The resulting maps of variations in the density and thickness of the tubular’s wall are very useful. Variations in tubular wall density highlight flaws (such as cracks, pits, de-laminations, etc) within the wall that might not otherwise be easily detected by surface contouring data taken by laser examination of the tubular’s surface. Variations in tubular wall thickness highlight wear on the tubular’s wall from a paradigm wall thickness.

**[0158]** The following sections of this disclosure now focus a mechanical inspection data acquisition system useful in conjunction with the ODS technology also disclosed herein. The ODS contour data acquisition and processing system, and related electronic control systems, described in the preceding paragraphs, dovetail into the disclosed mechanical inspection Data Acquisition System (“DAS”). The following DAS disclosure should also be read in conjunction with MLI disclosure in U.S. Provisional Application Ser. No. 61/707,780 (to which provisional application this application claims priority). Note, however, that although disclosed as part of the Scorpion System, the DAS technology could be used independently in many tubular processing operations. It is not limited to deployment on a tubular cleaning system.

**[0159]** Conventional technology calls for pipe joints and other tubulars to receive regular EMI (Electro-Magnetic Inspection or equivalent nomenclature) analysis to check the integrity of the joint. EMI analysis provides data, ideally in a graph format, interpretable to see, for example, if the tubular’s wall thickness has fallen below a certain acceptable thickness at any point, or if the tubular has any unacceptable defects such as pits or cracks.

**[0160]** EMI is conventionally provided by passing electromagnetic sensors over a stationary tubular, such as a joint of drill pipe. Alternatively, the tubular can be conventionally passed over a stationary electromagnetic sensor apparatus. This operation can be done in the shop or in the field. If an anomaly is found, the EMI sweep operation has to stop in order to pinpoint the anomaly. Further analysis is then done manually at the site of the anomaly (usually sonic analysis) to determine whether the pipe joint is in or out of specification. In some embodiments of the ODS, an EMI sweep operation may be configured by deploying an EM “donut” ring on ODS

assembly 220 as shown on FIGS. 5 through 10. The donut ring may sweep the tubular as ODS assembly 220 moves up and back above the rotating tubular.

**[0161]** The Scorpion System's DAS is an optional add-on to the other aspects of the Scorpion System disclosed elsewhere in this disclosure. The DAS provides sensors at suitable locations (such as, without limitation, on drift tooling or dedicated sensor lances on the MLI, or on the insides of shrouds or on a dedicated probe head on some embodiments of the ODS according to FIGS. 1 through 4, or as recorded by laser(s) and optical camera(s) onboard ODS laser 222 and by fixed lasers 224 on other embodiments of the ODS according to FIGS. 5 through 10). These sensors are provided to analyze the state of the rotating tubular. A further particularly advantageous sensor placement (without limitation) would be to locate a resistivity tool in an internal drift.

**[0162]** The DAS sensors may be of any suitable type for inspecting the tubular. The DAS sensors may be, for example, electromagnetic sensors, sonic sensors, lasers, cameras (still or video, optical or otherwise) accelerometers, or any other type of sensor, and the DAS is expressly not limited in this regard. Examination of the tubular by the sensors may be done at the same time that cleaning operations are done, or alternatively during separate inspection passes of the MLI or the ODS along the tubular.

**[0163]** It will be appreciated that the DAS may be enabled by any suitable data acquisition system capable of taking multiple sensor readings at high sampling rates, and then converting those readings into human-interpretable qualitative and quantitative data regarding the sampled specimen. Such data acquisition systems are well known in the art. The software also compares the sampled data with stored data, again in real time. As will be described in further detail below, the stored data may include, for example, earlier inspections of the same specimen, or paradigms such as theoretical scans of a specimen that meets applicable performance specifications.

**[0164]** A primary principle of the DAS is to acquire, in real time, sufficient data regarding the state of a tubular to have generated a unique and highly-individualized data "signature" of the tubular representing its current state as sampled. The signature represents any recorded and repeatable combination of sampled information points regarding the state of the tubular. Such sampled information points may include, by way of example and without limitation, qualitative and quantitative data regarding:

**[0165]** (a) location, shape and nature of anomalies on interior and/or exterior walls of tubular (such as scratches, scars, pits, gouges, repairs or cuts from prior service, or manufacturing defects of a similar nature);

**[0166]** (b) location and nature of variations in wall thickness of tubular;

**[0167]** (c) location and nature of variations in cross-sectional shape of the tubular; or

**[0168]** (d) location and nature of cracks or other points of weakness within the tubular.

**[0169]** The foregoing data is advantageously in high resolution. The more sampled information points regarding a tubular are combined into a signature, the more unique and highly-individualized the signature is likely to be. It will be appreciated that the "sample-richness" or "granularity" of the DAS signature of a tubular may be further enhanced by combining synchronous sampling of the exterior and interior of the tubular. One option for data acquisition in an illustrated

embodiment of the Scorpion System is for an MU lance with data acquisition capability and the ODS probe head or laser (as described elsewhere in this disclosure) to be run synchronously down the tubular with all such sensors (internal and external) being in data communication with each other. In this way, the DAS may acquire real time data regarding the tubular in which the data quality is enhanced by concurrent and substantially co-located sampling from both sides of the wall of the tubular. The DAS software and hardware is configured to allow a user to zoom in on points of interest on a graphical display in order to classify and measure anomalies.

**[0170]** A further feature in preferred embodiments of the DAS is a "stop/start curtain" that may be provided on embodiments of the ODS. The stop/start curtain is particularly advantageous in embodiments of the Scorpion System where "synchronous" examination (as described above) of the interior and exterior of the tubular is available. However, the curtain feature is not limited to such embodiments. The curtain feature refers to one or more sensors placed on each end of the ODS, and may use the optical range to be in the form of a "light" curtain. These sensors detect when the tubular is present underneath, and when it is not. The sensors may be lasers or lights (hence the colloquial reference to a "curtain") or any other sensor capable of such detection. As the ODS moves toward the tubular to commence operations, the curtain at the near end of the ODS detects the end of the tubular and synchronizes/coordinates DAS processing to this event. As the ODS nears completion of its travel over the tubular, the curtain at the near end of the ODS detects the end of the tubular and warns the DAS of this event. The curtain at the far end of the DAS eventually detects the end of the tubular and notifies that DAS that a full sweep of the tubular has been completed. It will be appreciated that the curtain feature may then be operated in reverse for a pass of the ODS along the tubular in the opposite direction.

**[0171]** Once acquired, the signature of the tubular may then be compared with the expected corresponding signature of a paradigm. The paradigm may be anything from the expected signature of a brand new, perfectly-manufactured tubular (the "perfect pipe"), to the expected signature of a tubular that meets all applicable performance specifications for the tubular when in service (for example, minimum wall thickness over a certain percentage of the tubular and no more than a certain number of pits, cracks or other anomalies above a certain size or depth). A summary report may then be produced that may summarize and highlight key points of interest in the comparison, including anomalies in OD measurements. In addition, the Scorpion System may generate "One-Way Tracking Tags" that may be affixed to each length of tubular processed by the System. Each tag advantageously includes serial number information (which may be in the form of bar codes) that ties the tubular to any corresponding cleaning and inspection information collected or generated by the Scorpion System.

**[0172]** It will be appreciated that with regard to comparison to the expected signature of a tubular that meets all applicable performance specifications, the DAS provides an advantageous substitute to conventional EMI analysis. Information regarding the condition of the tubular may be obtained concurrently with cleaning operations, potentially obviating the need for additional, separate EMI analysis after cleaning.

**[0173]** The current signature of the tubular may also be compared with earlier corresponding signatures of the same tubular to identify specific changes in the tubular since the

previous inspection. Alternatively, the current signature of the tubular may be compared against stored data sets or other known signatures where such a comparison will be expected to identify areas of interest in the tubular such as deterioration of wall integrity, or other wear or damage. Such stored data sets or known signatures might include, for example, “perfect pipe” in one type of comparison, or tubulars with known defects or wear and tear in another type of comparison.

**[0174]** In the currently preferred embodiment, the signature of the tubular appears as a series of graphs and other visual media. This makes comparison with paradigms or previous signature of the tubular relatively straightforward. Nothing in this disclosure should be interpreted, however, to limit the DAS or the Scorpion System in this regard.

**[0175]** One advantage of the DAS is that it is operable on a rotating tubular specimen. It will be appreciated that sensors scanning or sampling a rotating tubular are able to discern characteristics of the tubular that would either be undetectable or poorly detectable on a stationary tubular. For example, without limitation, the following characteristics are detectable (or better detectable) when the tubular is rotating:

**[0176]** (a) Vibrational frequency and amplitude;

**[0177]** (b) Harmonic response characteristics;

**[0178]** (c) Torsional displacement in response to torsional load; or

**[0179]** (d) Responses to sonic, optical or magnetic radiation

**[0180]** It will be further appreciated that by rotating the tubular during sensing or sampling, logs over the tubular become available that enable high resolution in pinpointing an item of interest, such as a defect or an anomaly, or a tubular identification or tracking tag. The sensing and sampling then goes well beyond accurate pinpointing, enabling real time qualitative analysis of the item of interest. As noted above, the DAS may obviate current manual electromagnetic and sonic analysis of lengths of tubulars, one-by-one.

**[0181]** Sensors on the DAS are connected to the processing unit by conventional telemetry, such as hard wire cables, wireless telemetry or optical cables. The telemetry selected will depend on environmental conditions such as distance over which telemetry is required, bandwidth and signal interference levels.

**[0182]** As disclosed earlier, the DAS may be embodied on any conventional data acquisition system whose performance matches the needs of the Scorpion System for obtaining, processing, comparing and displaying sensor readings and samples in real time. In a currently preferred embodiment of the DAS, however, the applicable software is advantageously customized to the Scorpion System via conventional programming to achieve the following operational goals and advantages:

**[0183]** (1) Receive and process a high sampling rate from many sensors, so as to effectively sample the tubular in real time with high resolution. Such high resolution comes not only from a high sample rate at each sensor, but also from concurrently processing samples from a high number of sensors.

**[0184]** (2) Display the output in easily-readable graphical formats, with the capability to “drill down” or “magnify” on areas of specific interest. The resolution level is able to support such magnification.

**[0185]** (3) Display the output against user selected paradigm(s) so that differences can be easily identified and characterized. The paradigms have the same resolution as the real

time data so that magnification of areas of interest supports a true, full comparison with the paradigm.

**[0186]** (4) Display the output remotely, allowing review of data and comparisons away from the machine. Such remote review may be enabled by transmission of local data to remote terminals, or by linking remote terminals to local terminals via conventional terminal-sharing applications such as GoToMeeting by Citrix.

**[0187]** A paradigm for optimal Scorpion System operating efficiency includes being able to program the ODS to run automatically. That is, to repeat a cycle of tubular exterior processing operations (including cleaning and data acquisition operations) as a series of tubulars are automatically and synchronously: (1) placed into position at the beginning of the cycle, (2) ejected at the end of the cycle, and then (3) replaced to start the next cycle. It may also be advantageous in some embodiments (although the Scorpion System is not limited in this regard) to synchronize ODS and MU operations. Specifically, embodiments of the electronic control system of the Scorpion System allow users to select a “Dirtiness Factor” for a tubular (or series thereof). The Dirtiness Factor reflects a weighted estimate including an assessment of the severity of the tubular’s contamination and the level of clean required by the Scorpion System. All speeds, pressures, distances and other relevant factors for cleaning operations are then automatically generated according to the Dirtiness Factor and fed into the cleaning systems of the Scorpion System. The goal by applying and following the Dirtiness Factor regimen is to clean the tubular 100% to the level selected before cleaning in one pass, without having to return and re-clean. As a result, the Scorpion System’s cleaning efficiency with respect to time and quality will be maximized, while still giving the desired level of clean. Similarly, the consumption of consumables such as brushes, liquids, fluids, etc., used in the cleaning process will be minimized, while still giving the desired level of clean.

**[0188]** In automatic mode on the ODS, the user may specify the sequence of ODS operations in a cycle on each tubular. The cycle of ODS operations will then be enabled and controlled automatically, including causing the ODS buggy to travel up and down above a tubular, with corresponding repositioning of ODS buggy (if required) with respect to the tubular. If applicable, the cycle may also include coordinating ODS operations in a cycle with concurrent MLI operations. The cycle may be repeated in automatic mode, as tubulars are sequentially placed into position. In semi-automatic mode, the operation may be less than fully automatic in some way. For example, a cycle may be user-specified to only run once, so that tubulars may be manually replaced between cycles. In manual mode, the user may dictate each ODS operation individually, and the ODS may then pause and wait for further user instruction.

**[0189]** For the avoidance of doubt, a “cycle” as described immediately above may comprise one pass or multiple passes of (1) the ODS, and/or of (2) user-selected lances in the MLI through each tubular, all in order to enable a user-selected sequence of operations. Nothing in this disclosure should be interpreted to limit the Scorpion System in this regard. Further, again for the avoidance of doubt, in a currently preferred embodiment of the Scorpion System, the ODS may run synchronously or asynchronously with some or all of the lances on the MLI, all according to user selection.



**[0190]** The Scorpion System as described in this disclosure is designed to achieve the following operational goals and advantages:

**[0191]** Versatility.

**[0192]** The Scorpion System as disclosed herein has been described with respect to currently preferred embodiments. However, as has been noted repeatedly in this disclosure, such currently preferred embodiments are exemplary only, and many of the features, aspects and capabilities of the Scorpion System are customizable to user requirements. As a result the Scorpion System is operable on many diameters of tubular in numerous alternative configurations. Some embodiments may be deployed onto a U.S. Department of Transport standard semi-trailer for mobile service.

**[0193]** Substantially Lower Footprint of Cleaning Apparatus.

**[0194]** As noted above, conventionally, the cleaning of range 3 drill pipe requires a building at least 120 feet long. Certain configurations of the Scorpion System can, for example, clean range 3 pipe in a building of about half that length. Similar footprint savings are available for rig site deployments. As also noted above, a mobile embodiment of the Scorpion System is designed within U.S. Department of Transportation regulations to be mounted on an 18-wheel tractor-trailer unit and be transported on public roads in everyday fashion, without requirements for any special permits.

**[0195]** Dramatically Increased Production Rate in Cleaning.

**[0196]** An operational goal of the Scorpion System is to substantially reduce conventional cleaning time. Further, the integrated yet independently-controllable design of each phase of cleaning operations allows a very small operator staff (one person, if need be) to clean numerous tubulars consecutively in one session, with no other operator involvement needed unless parameters such as tubular size or cleaning requirements change. It will be further understood that in order to optimize productivity, consistency, safety and quality throughout all tubular operations, the systems enabling each phase or aspect of such operations are designed to run independently, and each in independently-selectable modes of automatic, semi-automatic or manual operation. When operator intervention is required, all adjustments to change, for example, modes of operation or tubular size being cleaned, such adjustments are advantageously enabled by hydraulically-powered actuators controlled by system software.

**[0197]** Improved Quality of Clean.

**[0198]** It is anticipated that the Scorpion System will open up the pores of the metal tubular much better than in conventional cleaning, allowing for a more thorough clean. In addition, the high rotational speed of the tubular during cleaning operations allows for a thorough clean without a spiral effect even though cleaning may optionally be done in one pass.

**[0199]** Throughout this disclosure, reference has been made to software-driven electronic control systems and data acquisition/processing systems. It will be understood that such systems may be embodied on software executable on conventional computers, networks, peripherals and other data processing hardware.

**[0200]** Also, throughout this disclosure, conventional control, power and hydraulic/pneumatic actuating systems for features and aspects of the disclosed technology have been omitted for clarity. Likewise, conventional support structure

for features and aspects of the disclosed technology, such as structural steel, has been omitted for clarity.

**[0201]** Although the present invention and its advantages have been described in detail, it should be understood that various changes, substitutions and alternations can be made herein without departing from the spirit and scope of the invention as defined by the appended claims.

We claim:

1. An abrader train assembly, comprising:

a vertically-adjustable mounting mechanism including a horizontally disposed mounting member, the mounting member attached to the mounting mechanism such that, responsive to first user instructions, the mounting mechanism adjusts the mounting member to a predetermined abrader train elevation above a preselected horizontal datum plane;

at least one abrader assembly, each abrader assembly in independent spring-biased floating suspension from the mounting member, the floating suspension for each abrader assembly providing spring dampening of both upward vertical displacement and downward vertical displacement of the abrader assembly relative to the mounting member;

each abrader assembly further including a rotatable abrader configured to rotate about its own abrader rotation axis, wherein each abrader rotation axis is parallel to the datum plane;

each rotatable abrader including an abrasive surface at an outer periphery thereof;

a drive axle, each rotatable abrader in separate rotational power communication with the drive axle, the drive axle disposed to rotate at user-selected speeds about a drive axle rotation axis also parallel to the datum plane; and

wherein concurrent operational contact on the abrasive surface of each rotatable abrader causes independent vertical displacement of the corresponding abrader assembly against its spring dampening while each rotatable abrader rotates at a common user-selected speed.

2. The abrader train assembly of claim 1, in which at least one abrader assembly is in independent spring-biased floating suspension from the mounting member via the abrader assembly being suspended from two opposing compression springs separated by the mounting member.

3. The abrader train assembly of claim 1, comprising a plurality of abrader assemblies, and in which the abrader rotation axes of each of the rotatable abraders are parallel.

4. The abrader train assembly of claim 1, comprising a plurality of abrader assemblies, in which the abrader rotation axes of the rotatable abraders are substantially collinear when the abrader assemblies are in an equilibrium position suspended from the mounting member without operational contact on the abrasive surfaces.

5. The abrader train assembly of claim 1, further comprising a drive motor, the drive motor in rotational power communication with the drive axle.

6. The abrader train assembly of claim 5, in which the drive motor is selected from the group consisting of:

- (a) an electric motor;
- (b) a hydraulic motor; and
- (c) a pneumatic motor.

7. The abrader train assembly of claim 5, in which the rotation communication between the drive motor and the drive axle includes a drive belt.



8. The abrader train assembly of claim 1, in which the rotation communication between the drive axle and at least one rotatable abrader includes a drive belt.

9. The abrader train assembly of claim 5, in which the drive motor is mounted on the mounting member.

10. The abrader train assembly of claim 1, in which the drive axle is mounted on the mounting member.

11. The abrader train assembly of claim 3, in which the drive axle rotation axis is parallel to the abrader rotation axes of the rotational abraders.

12. The abrader train assembly of claim 1, in which the abrasive surface on at least one rotational abrader is selected from group consisting of:

- (a) a brush;
- (b) a flap wheel;
- (c) an abrasive stone wheel; and
- (d) a composite wheel.

13. The abrader train assembly of claim 1, in which the drive axle is configured to reverse rotational direction responsive to second user instructions.

14. The abrader train assembly of claim 1, in which at least one rotational abrader has an oblate spheroid shape.

15. The abrader train assembly of claim 1, comprising a plurality of abrader assemblies, in which there is a gap of about 1/16" between neighboring abrader assemblies.

16. An abrader train assembly, comprising:

a vertically-adjustable mounting mechanism including a horizontally disposed mounting member, the mounting member attached to the mounting mechanism such that, responsive to first user instructions, the mounting mechanism adjusts the mounting member to a predetermined abrader train elevation above a preselected horizontal datum plane;

a plurality of abrader assemblies, each abrader assembly in independent spring-biased floating suspension from the mounting member via the abrader assembly being suspended from two opposing compression springs separated by the mounting member, the floating suspension for each abrader assembly providing spring dampening of both upward vertical displacement and downward vertical displacement of the abrader assembly relative to the mounting member;

each abrader assembly further including a rotatable abrader configured to rotate about its own abrader rotation axis, wherein each abrader rotation axis is parallel to the datum plane;

each rotatable abrader including an abrasive surface at an outer periphery thereof;

wherein the abrader rotation axes of the rotatable abraders are substantially collinear when the abrader assemblies are in an equilibrium position suspended from the mounting member without operational contact on the abrasive surfaces;

a drive axle, each rotatable abrader in separate rotational power communication with the drive axle, the drive axle

disposed to rotate at user-selected speeds about a drive axle rotation axis also parallel to the datum plane; and wherein concurrent operational contact on the abrasive surface of each rotatable abrader causes independent vertical displacement of the corresponding abrader assembly against its spring dampening while each rotatable abrader rotates at a common user-selected speed.

17. The abrader train assembly of claim 16, further comprising a drive motor, the drive motor in rotational power communication with the drive axle.

18. The abrader train assembly of claim 16, in which the drive axle is configured to reverse rotational direction responsive to second user instructions.

19. An abrader train assembly, comprising:

a vertically-adjustable mounting mechanism, the mounting mechanism having an upper surface and a lower surface;

a plurality of independently-rotatable abrader assemblies attached to the mounting mechanism such that, responsive to first user instructions, the mounting mechanism adjusts the abrader assemblies to a predetermined abrader assembly elevation above a preselected horizontal datum plane;

each abrader assembly further comprising an abrader, a vertical support, an upper brush train spring, and a lower brush train spring;

each abrader assembly suspended from the mounting mechanism by its vertical support, each vertical support penetrating and perpendicular to the mounting mechanism, the upper brush train spring separating the vertical support from the upper surface of the mounting mechanism such that the abrader assembly is in floating suspension from the mounting mechanism via the upper brush train spring, the lower brush train spring separating the vertical support from the lower surface of the mounting mechanism such that the abrader assembly is also in floating suspension from the mounting mechanism via the lower brush train spring;

each abrader assembly, responsive to operational contact on its abrader, disposed to move vertically while the abrader is rotated at a user-selectable speed about an abrader rotation axis, wherein the abrader rotation axis for each abrader assembly is parallel to the datum plane; wherein further the abrader rotation axes are substantially collinear when the abrader assemblies are in an equilibrium position suspended from the mounting mechanism without operational contact on the abraders; and

a drive axle, each abrader in separate rotational power communication with the drive axle, the drive axle disposed to rotate at user-selected speeds about a drive axle rotation axis also parallel to the datum plane.

20. The abrader train assembly of claim 19, further comprising a drive motor, the drive motor in rotational power communication with the drive axle.

\* \* \* \* \*