

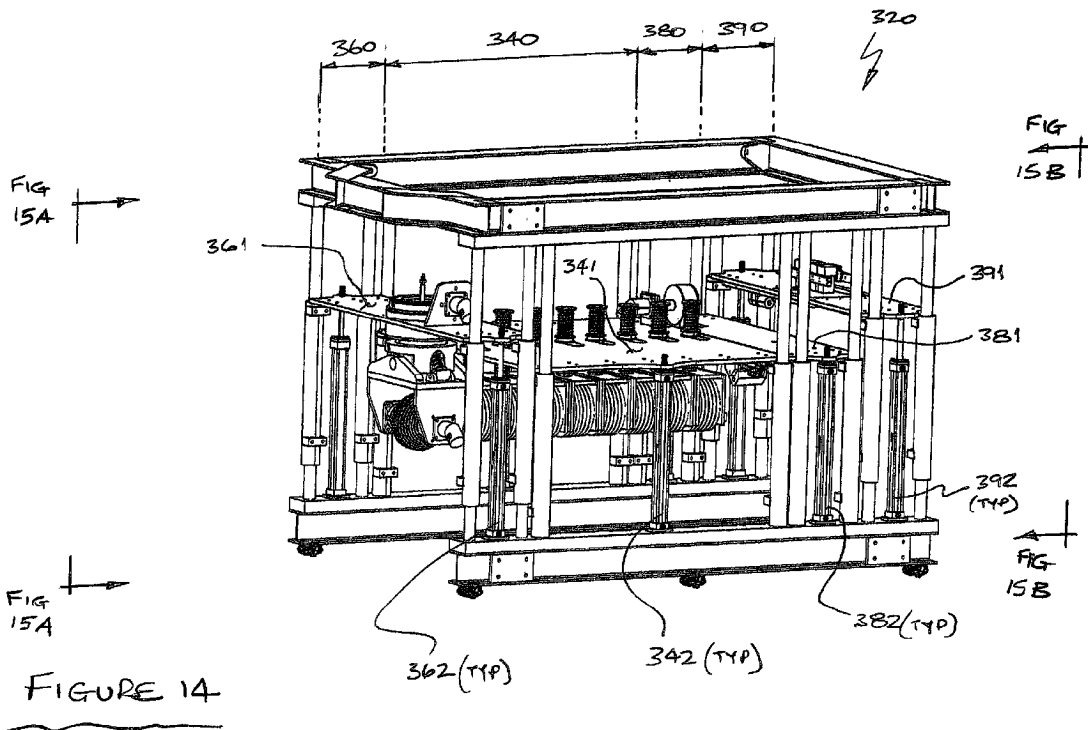

(86) **Date de dépôt PCT/PCT Filing Date:** 2013/09/30  
 (87) **Date publication PCT/PCT Publication Date:** 2014/04/03  
 (85) **Entrée phase nationale/National Entry:** 2015/03/25  
 (86) **N° demande PCT/PCT Application No.:** US 2013/062778  
 (87) **N° publication PCT/PCT Publication No.:** 2014/052990  
 (30) **Priorités/Priorities:** 2012/09/28 (US61/707,780);  
 2013/03/15 (US61/799,425)

(51) **Cl.Int./Int.Cl. B08B 9/023** (2006.01),  
**F16L 55/18** (2006.01)  
 (71) **Demandeur/Applicant:**  
 THOMAS ENGINEERING SOLUTIONS &  
 CONSULTING, L.L.C., US  
 (72) **Inventeurs/Inventors:**  
 THOMAS, WILLIAM C., US;  
 THOMAS, WILLIAM J., III, US;  
 DECUIR, PERRY J., JR., US;  
 WHEELER, JEFFREY R., US;  
 PERRY, KENNY, JR., US  
 (74) **Agent:** MBM INTELLECTUAL PROPERTY LAW LLP

(54) **Titre : NETTOYAGE ET INSPECTION EXTERNES AMELIORES DE TUBES**  
 (54) **Title: ENHANCED EXTERNAL CLEANING AND INSPECTION OF TUBULARS**



(57) **Abrégé/Abstract:**

Enhanced methods are disclosed for performing operations such as cleaning, inspection or data acquisition on an external surface of a hollow cylindrical tubular. Preferred embodiments include providing a fluid dispenser and an abrasion assembly on a buggy that travels up and down the length of the tubular as the tubular rotates. The fluid dispenser includes nozzles that dispense cleaning fluids onto the tubular's external surface. The abrasion assembly includes a swivel brush and a brush train providing different styles of abrasion cleaning of the tubular's external surface. Preferred embodiments of the buggy also carry a range finding laser and an optical camera generating samples that may be processed in real time into data regarding the surface contours and the diameter variations on the tubular's external surface. Cleaning and inspection variables such as tubular rotational speed, or buggy speed, may be adjusted responsive to measured surface contour data.